

# Pioneer Eclipse

An **AMANO** Company

**SAFAR** TECHNOLOGY



UHS Propane Burnisher  
**PE440BU**  
Operator's Manual



**CE**



## **Instructions For Use**

Failure to read and understand this manual before operating this machine or performing service on this machine may result in injury to the operator or nearby personnel or result in damage to the machine or nearby property. Each operator must be trained in the operation of this machine before being allowed to use it. Contact Amano Pioneer Eclipse Customer Service at 1-800-367-3550 or +1-336-372-8080 or an authorized Amano Pioneer Eclipse Distributor to inquire about training or to request a replacement manual.

## **NOTICE**

Proper maintenance is necessary with all propane powered floor machines. Following the scheduled maintenance procedures found in your operation manual will provide many years of uninterrupted service.



In addition to the scheduled maintenance procedures listed it is recommended to have your machine serviced by certified service personnel every three months. This service should include an emissions check.

**DANGER!** For your safety, if you smell propane:

1. Extinguish any open flame.
2. Open window.
3. Do not touch electrical switches.
4. Immediately call your propane supplier.

**DANGER!** Do not store or use gasoline or other flammable vapors and liquids in the vicinity of this or any other appliance.

**Record This Important Information**

Date of Purchase \_\_\_\_\_

Purchased From \_\_\_\_\_

Address \_\_\_\_\_

City \_\_\_\_\_ State \_\_\_\_\_ Zip \_\_\_\_\_

Phone \_\_\_\_\_ Contact \_\_\_\_\_

Machine Model \_\_\_\_\_

Machine Serial Number \_\_\_\_\_

**Important Phone Numbers**

Medical Emergency \_\_\_\_\_

Police \_\_\_\_\_

Fire Department \_\_\_\_\_

In this Operation Manual you will find three statements that you must read and observe to ensure safe operation of this machine.

**DANGER!** indicates that the possibility of severe bodily injury or death can occur if DANGER! statements are ignored. Read and observe all DANGER! statements included in the Operation Manual and attached to the machine.

**WARNING!** indicates that the possibility of bodily injury to the operator and other people can occur if WARNING! statements are ignored. Read and observe all WARNING! statements included in the Operation Manual and attached to the machine.

**CAUTION!** indicates that the possibility of damage to the machine or other property can occur if CAUTION! statements are ignored. Read and observe all CAUTION! statements included in the Operation Manual and attached to the machine.

# Table of Contents

Quick Reference Specifications.....	6	Spark Plug Inspection and Replacement.....	23
Safety Precautions.....	7	Hood Removal.....	23
Refueling and Storage of Fuel Cylinders.....	9	Air Filter Inspection and Replacement.....	23
Operator Responsibility.....	9	Engine Dust Filter.....	24
Canadian Safety Requirements.....	10	Valve Clearance & Re-torque Heads.....	24
Test for Operator-Ear Sound Pressure Level.....	11	Valve Seating.....	24
Test for Hand Arm Vibration.....	11	Head Bolt Maintenance.....	24
Machine Preparation.....	12	Cooling Fin Maintenance.....	24
Unpacking the Machine.....	12	Inspect Fuel Hose and Connections.....	24
Filling the LP Cylinder.....	12	Inspect Pad and Pad Holders.....	25
Installing the LP Cylinder.....	12	Belt Maintenance.....	25
Controls and Instruments.....	13	Belt Replacement.....	25
Engine Ignition Switch.....	14	Battery Maintenance.....	26
Bail Throttle.....	14	Machine Storage.....	26
Hour Meter/Tachometer.....	14	Repacking the Machine.....	26
SafeSense Emissions Monitoring.....	15	Transporting the Machine.....	26
Rok-Bak & Pad Change.....	16	Machine Specifications.....	27
Wheel Adjustment.....	16	Parts Manual.....	28
Handle Adjustment.....	17	Electrical Schematic.....	29
Fuse.....	17	Connections.....	30
Dust Bag.....	17	Engine Assembly.....	32
How the Machine Works.....	18	Bulkhead Assembly.....	34
Pre-Operation Checklist.....	18	Old Deck Assembly.....	36
LP Fuel Cylinder.....	18	Old Main Assembly.....	38
Installing the LP Fuel Cylinder.....	18	Deck Assembly.....	40
Starting the Machine.....	19	Main Assembly.....	42
Idling and Stopping the Machine.....	19	Regulator, Handle, & Hood Assembly.....	44
Burnishing.....	19	Skirt & Pad Holder Assembly.....	46
Machine Troubleshooting.....	20	Small Off Road Engine Certification Warranty.....	48
Maintenance.....	21	Safety Awareness Form.....	49
Scheduled Maintenance Chart.....	21	Manufacturer's Warranty.....	51
Oil Level Inspection.....	22		
Oil Change.....	22		
Oil Filter Replacement.....	23		

## Quick Reference Specifications:

### Capacities:

- Engine Oil:
  - Filter not removed: 1.6qt. (1.5L)
  - Filter removed: 1.8qt. (1.7L)
  - Engine Oil Type: SAE30 with API Service Classification SH or SJ

### Routine Maintenance Parts:

- Engine Dust Filter (Hood): MP373400
- Engine Oil Filter: KA490657007
- Engine Primary Air Filter (Paper Element): KA110130752
- Engine Air Pre-Cleaner (Foam Element): KA110137046
- Spark Plug: KA920702112
- Battery: MP362200
- Drive Belt: MP8070 (21")  
MP8049 (24")  
MP272900 (28")
- Fuses: SS2570 (20A)  
MP043000 (7.5A)
- LP Cylinder: MP105900 (Steel)

Your Authorized Amano Pioneer Eclipse Distributor: \_\_\_\_\_

Authorized Amano Pioneer Eclipse Distributor Phone Number: \_\_\_\_\_

Amano Pioneer Eclipse Phone Number: +1-336-372-8080

## Safety Precautions

Anyone operating the machine should read the following carefully and be informed of potentially dangerous operating conditions. Operators should be familiar with the location and use of all safety devices on the machine. Do not use the machine if it is not in proper operating condition, and report any damage or operation faults immediately.

**DANGER!** Operate this machine in a well-ventilated area. It is the responsibility of the machine operator, machine owner, and the site manager to ensure that the air exchange system where the machine is to be used is in compliance with local building codes and is operating properly. Failure to operate this machine in a well-ventilated area could lead to sickness, injury, or death from carbon monoxide (CO) exposure.

**DANGER!** This machine emits CO, which is colorless, odorless, non-irritating gas. The first symptoms of CO exposure include headache, drowsiness, dizziness, and nausea. If you should experience any of these symptoms while operating the machine, shut off the machine and go outside to get fresh air. Have the machine tested for CO emissions by a qualified service technician before using it again.

**DANGER!** Prolonged or high exposure to CO may result in vomiting, confusion, and collapse in addition to loss of consciousness and muscle weakness. If such symptoms occur, call 911 for emergency medical attention. If you have experienced these symptoms, **DO NOT** operate this machine or any other propane machine again until cleared by a physician. Excessive exposure to CO can result in death.

**DANGER!** Propane is a highly flammable fuel. If you smell propane, shut off the machine immediately and take it outside the building. **DO NOT** use the machine again until a qualified service technician has corrected the propane leak. **DO NOT** use or allow another person to use an ignition source such as a cigarette lighter near the propane machine. **DO NOT** smoke near the propane machine. **DO NOT** vent a propane cylinder inside a building. **DO NOT** store propane cylinders inside a building.

**DANGER!** This machine has parts, including the pad assemblies, that can cause severe injury if these parts are contacted while they are moving. **DO NOT** allow any part of the body or clothing to come in contact with these parts while they are moving. **DO NOT** try to change attachments while the machine is running. **DO NOT** allow other people to come near the machine while it is in operation. **DO NOT** allow the machine to run unattended. **DO NOT** leave the machine in a place where unauthorized or untrained personnel could use the machine. **DO NOT** run the machine with the pad off center, damaged or missing. **DO NOT** run machine with unsecured guards and shields. **DO NOT** operate the machine if the machine has loose parts.

**DANGER!** Federal law and California State law prohibits the following acts or the causing thereof: (1) the removal or rendering inoperative by any person other than for purposes of maintenance, repair, or replacement, of any device or element of design incorporated into any new engine for the purpose of emission control prior to its sale or delivery to the ultimate purchaser or while it is in use, or (2) the use of the engine after such device or element of design has been removed or rendered inoperative by any person.

Among those acts presumed to constitute tampering are the acts listed below: **DO NOT** tamper with the original emission related part.

- Throttle body and internal parts
- Spark plugs
- Magneto or electronic ignition system
- Air cleaner elements
- Crankcase
- Cylinder heads
- Breather chamber and internal parts
- Intake pipe and tube
- Regulator
- Fuel lock-off

**WARNING!** Overfilled or liquid withdraw cylinders can damage the fuel system and create a fire hazard. **DO NOT** overfill the cylinder or use a liquid withdraw cylinder on the machine. If the regulator freezes stop the burnisher and take the cylinder outside. Inspect cylinder, if a vapor withdraw cylinder, use gloves or pliers to open bleeder valve and purge cylinder until only vapor is escaping. If it is a liquid withdraw cylinder, replace with a vapor withdraw cylinder. Both cylinders are shown below.

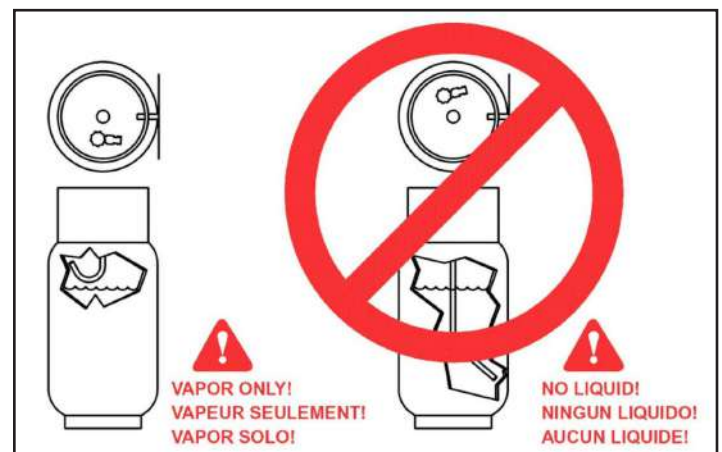

**WARNING!** Modifications or alterations to this machine can lead to personal injury or damage to the machine. **DO NOT** make unauthorized modifications or alterations to this machine. Amano Pioneer Eclipse assumes no liabilities for injury or damage resulting from an unauthorized modification or alteration to the machine. Any unauthorized modification or alteration to this machine voids all warranties.

**WARNING!** The muffler and the engine become hot enough while the machine is in operation, and for a long time after the machine is shut off, to cause severe burns. **DO NOT** touch these parts of the machine until they have cooled.

**WARNING!** Injury can occur to the eyes and body while using the machine. Safety goggles, safety shoes, and safety clothing are recommended while operating the machine.

**WARNING!** Continuous exposure to high noise levels can cause hearing loss. Hearing protection is recommended while the machine is in operation.

**WARNING!** Machine vibration may cause tingling or numbness in the fingers or hands. Gloves are recommended to reduce machine vibration. If tingling or numbness persists, shut off the machine. If the vibration is caused by loose parts, adjust or tighten these parts before using the machine again.

**CAUTION!** A dirty engine filter can cause overheating. Check and replace following recommended maintenance schedule.

**CAUTION!** Overheating can be caused by insufficient or low oil. Check oil before each use, and fill or change as needed.

**CAUTION!** Never over-fill engine with oil. Over-filling could cause irreparable damage to the engine.

**CAUTION!** Overheating can be caused by dirty oil. Check oil before each use and change regularly following recommended maintenance schedule.

**CAUTION!** Do not engage starter for more than 5 seconds. Allow a 10 second cool-down period for second failed start-up attempt.

**CAUTION!** Perform all recommended scheduled maintenance. Regular maintenance of your propane powered floor machine is necessary to keep it in safe working condition.

**CAUTION! DO NOT** operate machine unless trained and authorized. **DO NOT** operate machine unless you have read and understand the operation manual. **DO NOT** operate machine in flammable or explosive areas.

**CAUTION!** Before starting machine ensure all safety devices are in place and functioning properly. Before starting machine check for proper operation.

**CAUTION!** When using machine, go slowly on inclines or slippery surfaces. Use care when operating machine in reverse.

**CAUTION!** When servicing machine, stay clear of moving parts. **DO NOT** wear loose clothing when working on machine. Block machine wheels before raising or jacking up machine. Use hoist stands that will support the weight of the machine. Wear eye and ear protection when using pressurized air or water. Disconnect battery connections before servicing machine. Use only replacement parts supplied by Amano Pioneer Eclipse or a Amano Pioneer Eclipse Authorized Distributor or Service Center.

**CAUTION!** When loading or unloading machine onto or off a truck or trailer, turn machine OFF. Only use a truck or trailer that will support the weight of the machine to transport. **DO NOT** push the machine onto or off a truck or trailer unless the load height is 15 in (380mm) or less from the ground. Block machine wheels when transporting. Tie the machine down securely to truck or trailer when transporting.

### ***This machine is manufactured for commercial use only.***

This machine is designed and manufactured for indoor use in burnishing wax coated hard floor surfaces. Amano Pioneer Eclipse does not recommend use of this machine in any environment other than an indoor environment. This propane powered floor machine is designed and manufactured for commercial floor burnishing only. This machine is designed to burnish most modern types of floors including composition tile, stone, marble, terrazzo, and resilient floor covering, and some coated wood floors. Even though NFPA 11.13.2.3 says..."the use of floor maintenance machines in buildings frequented by the public, including the times when such buildings are occupied by the public, shall require the approval of the authority having jurisdiction." Amano Pioneer Eclipse suggests usage when occupancy of a given work area is minimal.

### ***These machines should not be used***

- In nursing homes, hospitals, day-care centers, etc. that are occupied.
- By unqualified or untrained personnel.
- Unless properly maintained and adjusted.
- On areas with obstructions such as thresholds, floor outlet boxes, etc.
- In areas where loose debris or other objects are present.
- In rooms and areas without proper ventilation.

### ***Operator Responsibility***

The operator is responsible for performing the recommended daily maintenance and checkups of the machine to keep it in good working condition. The operator must inform the service mechanic or supervisor when recommended maintenance procedures are required as described in the "MAINTENANCE" section of this manual.

- Read this manual carefully before operating this machine.
- FOR SAFETY: **DO NOT** operate machine before reading and understanding the operation manual.
- Check the machine for shipping damage.

Keep your machine regularly maintained by following the maintenance information in this manual. Order parts and supplies only from an Authorized Amano Pioneer Eclipse Distributor. Use the parts illustration section of your manual when ordering parts. During and after operation, perform the recommended daily and hourly procedures outlined in the Maintenance Chart.

### ***Refueling and Storage of Fuel Cylinders***

This machine uses a 20lb (9.1kg) capacity aluminum or steel cylinder, which meets the DOT 4E240 standards. These cylinders are also listed by UL. In addition, the steel cylinder meets European TPED specifications and is CE compliant. Filling should be done **ONLY** by a qualified propane dealer. **FILL THROUGH THE SERVICE VALVE ONLY.** A properly filled cylinder should not exceed 80% of the rated capacity.

**DO NOT** attempt cylinder repair. Return the cylinder to your propane dealer if repair is necessary. Please note that DOT regulations prohibit shipping of cylinders after the cylinder has been filled with propane. When not in use, cylinders should always be stored outside in an upright position in a secure, tamper-proof, steel mesh storage cabinet. The cabinet may be located next to the building, but with at least five feet (1.5 m) of space between the cabinet and the nearest building opening (door or window).

The cylinder to be used on this machine is a vapor withdraw cylinder. **A liquid withdraw cylinder is not to be used with this machine.** The use of a liquid withdraw cylinder on a vapor withdraw system could freeze the regulator and create a fire hazard. The National Fire Protection Association (NFPA) Standard for Storage and Handling of LP Gas is the appropriate authority for safe propane use. A copy of this publication is available through the National Fire Protection Association (1-800-344-3555) or [www.NFPA.org](http://www.NFPA.org).

## Canadian Safety Requirements

1. A sign indicating "NO SMOKING" shall be permanently displayed at the storage area. The sign shall be in accordance with the sign required in Clause 10.12.3 of CAN/CGA-B149.2-M91, Propane Installation Code.
2. When the cylinder is attached to the floor maintenance machine for use, the operator shall not leave the unit unattended except for short periods of time such as rest stops, washroom, or meal stops.
3. The requirements of 1.10.1 (e) and (g) do not apply in industrial buildings.
4. A floor maintenance machine shall only be used in buildings:
  - a. Provided with continuous mechanical ventilation that removes products of combustion to the outdoors of not less than 300 CFM for each 10,000 BTU-hr or fraction thereof.
  - b. Provided with natural ventilation of not less than 300 CFM for each 10,000 BTU-hr input or fraction thereof, based on a maximum of one-quarter-air exchange per hour for the net building volume.
5. The owner of a floor maintenance machine shall ensure that the operator has participated in a course authorized by the manufacturer of the unit on the safe handling of propane and the safe operation of the machine.
6. The owner of a floor maintenance machine shall ensure that the unit is maintained in accordance with the manufacturer's recommended maintenance procedures in a safe operating condition and the owner shall maintain a record of the maintenance for a period of two years.
7. Before transporting a floor maintenance machine, the cylinder shall be securely fastened with the system valve closed, and the cylinder shall be located in a well-ventilated space.

## Exigences de sécurité pour le Canada

1. Un panneau indiquant " INTERDICTION DE FUMER " doit être affiché en permanence dans la zone de stockage. Il doit être conforme au panneau exigé par la Clause 10.12.3 du CAN/CGA-B149.2-M91, Code installation propane.
2. Lorsque le cylindre est fixé à la machine d'entretien des sols pour son utilisation, l'opérateur ne doit pas laisser l'unité sans surveillance, sauf pour de courtes périodes, notamment pour faire une pause, aller aux toilettes ou au moment des repas.
3. Les conditions du 1.10.1 (e) et (g) ne s'appliquent pas aux bâtiments industriels.
4. Une machine d'entretien des sols ne doit être utilisée que dans les bâtiments suivants :
  - a. Équipés d'un système de ventilation mécanique ininterrompu, capable d'évacuer les produits de combustion vers l'extérieur, non inférieur à 300 CFM pour chaque 10 000 BTU/h ou une fraction de ce dernier.
  - b. Équipés d'un système de ventilation naturel non inférieur à 300 CFM pour chaque 10 000 BTU/h ou une fraction de ce dernier, basé sur un maximum d'un quart d'air échangé par heure pour le volume net du bâtiment.
5. Le propriétaire d'une machine d'entretien des sols doit s'assurer que l'opérateur a participé à une formation habilitée par le fabricant de l'unité, relative à la manipulation sûre du propane et de la machine.
6. Le propriétaire d'une machine d'entretien des sols doit s'assurer que l'unité bénéficie d'un entretien conforme aux procédures de maintenance recommandées par le fabricant dans des conditions d'utilisation sûres. De plus, il doit tenir un registre de la maintenance sur une période de deux ans.
7. Avant de transporter une machine d'entretien des sols, le cylindre doit être fixé de manière sûre avec le système de soupapes fermé. De plus, il doit se trouver dans un espace bien ventilé.

### **Test for Operator-Ear Sound Pressure Level**

Amano Pioneer Eclipse measures and rates the operator-ear sound pressure level for hand-guided floor treatment and floor cleaning machines for industrial use. All tests are performed in accordance with European Machinery Directive (2006/42/EC).

- Outdoor test area consists of a flat open space free from effects of signboards, buildings or hillsides for at least 15 m (50 ft) from the center of the test surface. Indoor tests are conducted in a semi-anechoic or sound deadening room.
- The test surface is a single sheet of floor covering at least 1 m (3.3 ft) wider and longer than the equipment being tested. In order to not affect the sound reading, the observer taking readings is at least 2 m (6.6 ft.) from the equipment being tested, or standing directly behind the operator.
- All machines are tested while stationary and centered on the test surface. With the traction drive in neutral (where applicable) the test is conducted with the machine at maximum engine or motor speed as specified by the manufacturer.
- The operator is located in the normal operating position with the microphone or meter supported independent of the machine, 1,68 m (66 in) above the test surface, 25 cm (10 in) to the right and left centerline of the operators position, and 20 cm (8 in) to the rearmost point of the handle, with the handle in the most forward position.
- The sound level meter is observed for a minimum of 5 seconds or until a stabilized reading is obtained. The maximum repeatable sound level observed during the test at each microphone position is recorded and documented.

### **Test for Hand-Arm Vibration at the Grip Surface of Hand-Guided Machinery**

Amano Pioneer Eclipse measures and rates the vibration at the machine-hand contact surface of hand-guided machines that are provided with handles in accordance with European Machinery Directive (2006/42/EC).

- The test area consists of a flat open floor area that allows the machine to be operated normally.
- The transducer is mounted firmly at a point halfway along the length of the handle where the handle would normally be held.
- Machines are tested while stationary, with all mechanisms necessary for the equipment to perform its intended functions engaged and the traction drive in neutral (if applicable). The machine will be tested at maximum engine or motor speed as specified by the manufacturer of the subject machine.
- The measurements are recorded from the dominant axis.

# Machine Preparation

## Unpacking the Machine

The machine is shipped boxed on a wooden pallet. To unpack machine:

1. Cut and remove bands holding the box to the pallet.
2. Remove staples attaching the box to the platform at the bottom edge of the box.
3. With two people, one at either end of the box, lift box straight up and off machine.
4. Cut and remove bands securing the machine to the pallet.
5. Remove back brace.
6. Loosen the handle pivot knobs on both sides of the bulkhead and pull up on the handle. .

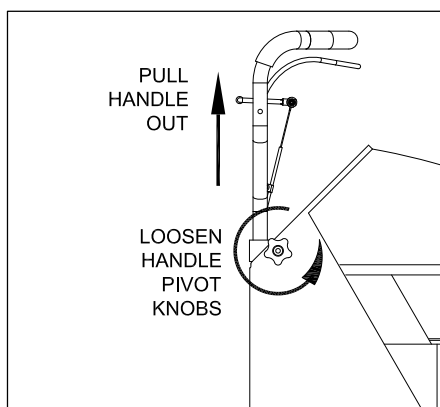

7. Rotate handle downward to the operating position.

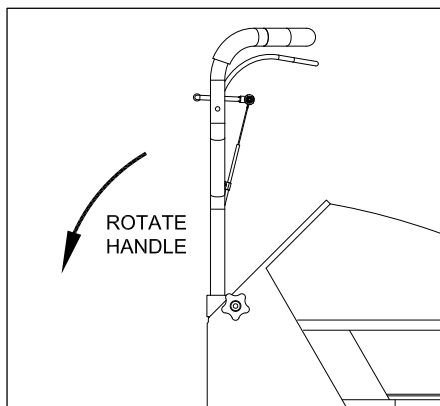

8. Push the handle inward until the handle stops.

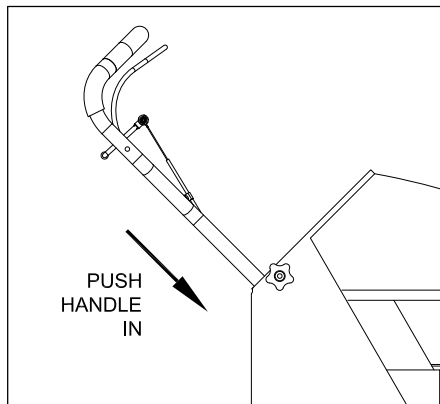

9. Tighten the handle pivot knobs on both sides of the bulkhead.

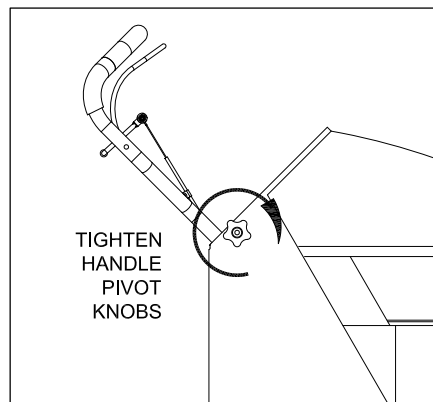

10. Check machine fluid levels (engine oil). See *Maintenance* section.

**NOTE: If machine was shipped by airfreight, add engine oil.**

11. Carefully back the machine off of the pallet.

## Filling the LP Cylinder

This machine uses the 20 lb (9.1 kg) capacity cylinder, which meets the D.O.T. 4E240 standards. These cylinders are also listed by UL. In addition, the steel cylinder meets European TPED specifications and is CE compliant. Filling should be done **ONLY** by a qualified propane dealer. A properly filled cylinder should not exceed 80% of the rated capacity. Do not overfill the cylinder or use a liquid withdraw cylinder on the machine. The use of a liquid withdraw cylinder on a vapor withdraw system could freeze the regulator and create a fire hazard.

## Installing the LP Cylinder

Place the cylinder on the cylinder platform at the back of the machine. Connect the fuel hose coupling to the service valve by turning to the right (clockwise). **HAND TIGHTEN ONLY!** Make sure coupling is not cross threaded and check for leakage by noting any propane odors immediately after cylinder is connected. Finally, secure the tank to the machine using the adjustable strap. Remove slack by pulling on the loose end and securing with the Velcro.

**TO REMOVE THE LP CYLINDER**, reverse the above procedure. Always connect or change cylinders in a well-ventilated area.

# Machine Components

## Controls and Instruments



## Engine Ignition Switch

This machine features a key switch ignition.

**Start:** Turn the key all the way clockwise to engage the engine starter motor. Once the engine starts release the key.

**NOTE:** Always start this machine with the bail throttle in the idle or “slow” position.

**Run:** This is the position of the key while the engine is running.

**Off:** Turn the key to the “OFF” position to stop the engine from running.

**NOTE:** For safety, always close the propane cylinder valve to stop the engine and then turn the key switch to the “OFF” position.



## Hour Meter / Tachometer

The hour meter / tachometer records the number of hours the machine has been powered ON. The hour meter reading is used to mark recommended maintenance intervals. It also displays the engine speed. This meter displays hours when the machine is turned OFF and engine speed when the machine is turned ON.



## Bail Throttle



Do not try to start the machine with the bail throttle in the operating position.

After the engine has started, with the pad off of the floor, pull the bail throttle to the operating position. The clutch will engage automatically and the engine will throttle to the correct speed.

**CAUTION! DO NOT** pull the bail throttle with the burnishing head lowered to the floor.

Release the bail and the clutch will automatically disengage. The engine speed will return to idle.

## SafeSense Emissions Monitoring System

SafeSense is an emissions monitoring device that monitors the exhaust emissions and will shut the engine down if the emissions levels are too low or too high.



**NOTE:** After engine starts, the YELLOW alert light will flash for a 3 minute warm-up cycle of the SafeSense system. (The machine may be operated during this warm-up period.) After the warm-up cycle, the alert light will go out. None of the SafeSense lights will be illuminated as long as the machine is running safely.

**OIL:** Light comes on when there is low oil pressure. If the engine loses oil pressure, the engine shuts down until the condition is corrected. The light comes on each time the engine is stopped.

**TILT/IDLE:** Light comes on when the machine is tilted to the pad change position and the engine shuts down. If the machine is allowed to idle for more than 4 minutes, the light flashes for 1 minute then the engine shuts down.

**RED SafeSense SERVICE:** If carbon monoxide levels exceed a pre-set level, the light will flash. The machine will shut down after the light flashes continuously for one minute. If the machine does not operate normally after the engine air filter is checked and cleaned, it must be serviced by a qualified technician.

**OXYGEN SENSOR:** If light comes on during normal operation, check the oxygen sensor wire for a snug fit into the harness and for a snug fit of the harness into the SafeSense board. If the light still remains on, the machine must be serviced by a qualified technician.

**TURN GAS OFF:** Light comes on to remind the operator to turn off the gas after the engine shuts down.

**BATTERY:** Light comes on when the battery voltage is low indicating the need to service charging system.

**YELLOW SafeSense ALERT:** If light comes on during normal operation, check and clean the engine air filter. Check the carburetor air filter for holes, tears, or punctures and replace if damaged. If the light still remains on, the machine must be serviced by a qualified technician.

**NOTE:** Any light that is on when the engine stops will remain illuminated for 20 seconds to indicate the reason for machine shut down.

The oxygen sensor must reach operating temperature before it will start to send signals to the SafeSense module. This warm up period is approximately 3 minutes. After the initial 3 minutes, the module will start evaluating the signal from the oxygen sensor and if the module receives an abnormal reading for a period of 1 minute, the unit will shut down. If the machine is also allowed to idle for more than 4 minutes, an indicator light will flash for 1 minute and then the engine will shut down. If this happens, turn the key to the "off" position several seconds to clear the SafeSense module and restart the engine. Once the engine has started, advance the bail throttle to operating position and start the operation. With the engine at full throttle, under load, the signal from the oxygen sensor should be within the normal operating ranges for safe operation. If the engine's air intake filter needs to be serviced, or an over-filled cylinder has been installed by mistake, or there is a problem with the fuel system that causes the oxygen sensor's signal to be out of range, SafeSense will shut the unit down after 1 minute. The unit can be re-started after clearing the module by turning off the key switch. If corrections have not been made to the unit, SafeSense will continue to shut the unit down until the problem is corrected.

Engines tend to go to a lean burn if allowed to idle for even short periods. Even at high idle speeds most engines will continue to lean downward. It is always best to shut the engine off when it is not being used to do work. Remember, the engine is always creating emissions as long as it is running.

The best manner to operate a unit equipped with SafeSense is as follows.

1. With the bail throttle in the idle position, turn the key switch to the start position, once the engine starts, advance the bail throttle to the operating position.
2. When ready to stop operation, release the bail throttle. If the unit will not be used within forty-five seconds, turn the key switch to the off position. If the unit will not be returned to service within a few minutes it is best to turn the gas valve on the tank off first and let the engine consume all fuel that is in lines. Once the engine dies, turn the key switch to off position.
3. When ready to restart, open the gas valve on the tank, and turn key switch to the start position. Once the engine has started, move bail throttle to the operating position and return to operation.

**SAFR™** technology monitors the pressure between the air filter and the carburetor. As the air filter becomes dirty, this pressure decreases. With **SAFR™** technology, this change in pressure results in a reduction in fuel delivered to the engine. The net result is a Steady Air Fuel Ratio regardless of the air filter condition.

## Rok-Bak & Pad Change

1. Close the valve on the propane cylinder, allow the engine to stop and turn the machine OFF.
2. Remove the propane cylinder.
3. Loosen the handle pivot knobs on each side of the bulkhead.
4. Pull the handle out until it stops.
5. Rotate the handle towards the front of the machine until it is vertical.
6. Push downward on the handle until it stops.
7. Tighten the handle pivot knobs so the handle cannot move or slide.

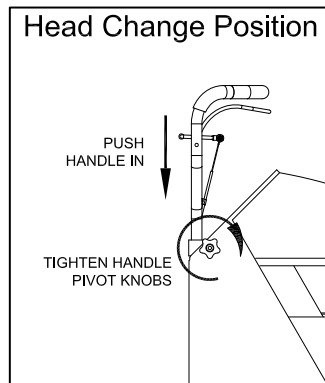
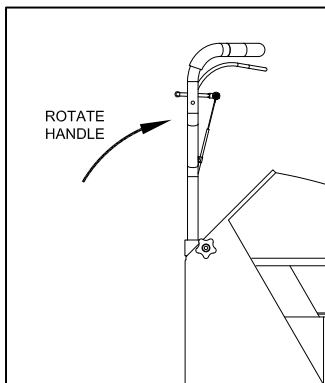
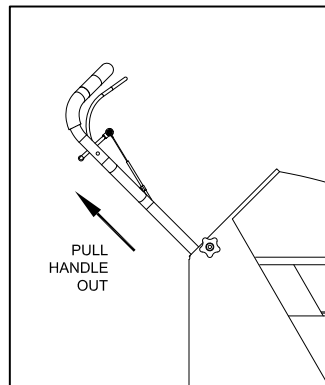
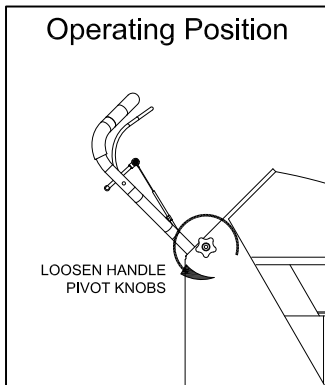

8. Lift up on the front of the deck rocking the machine back until it rests on the handle grips.



5. Remove centering device and inspect pad. If pad has worn to less than a 1/4" (6mm) thick, replace it.



**CAUTION!** Carefully inspect the pad holder for cracks or damage. Replace if necessary.

**WARNING!** A damaged pad holder rotating at high speeds may be an extreme hazard if it should come apart.

6. When lowering the machine down, do not drop the machine. Slowly lower the machine to the floor until the wheels are on the ground.

## Wheel Adjustment

1. Close the valve on the propane cylinder, allow the engine to stop and turn the machine OFF.
2. Remove the propane cylinder.
3. Place the machine in the pad change position (see Rok-Bak section).
4. Remove the pin that retains each wheel and relocate to the desired wheel position.



**NOTE:** To increase pad pressure (more aggressive) move wheels to rear of machine. To decrease pad pressure (less aggressive) move wheels toward the front of machine.

## Handle Adjustment

1. The height of the handle can be adjusted by raising or lowering the handle.
2. Loosen the handle pivot knobs on the sides of the bulkhead, turning the right side counter-clockwise and the left side clockwise.

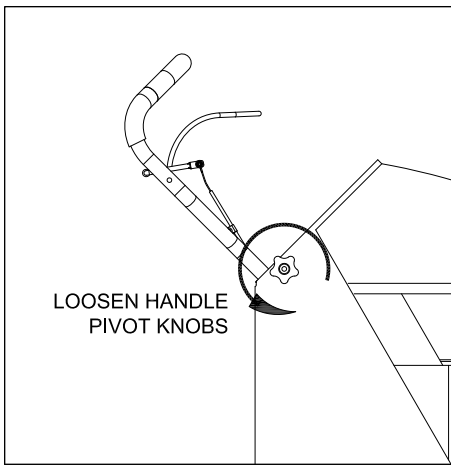

3. Move the handle in and out to the desired height

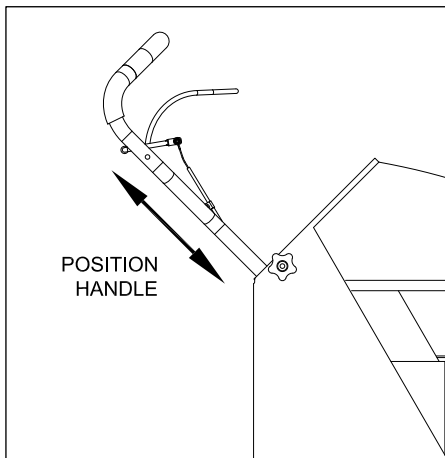

4. Tighten the handle pivotknobs.

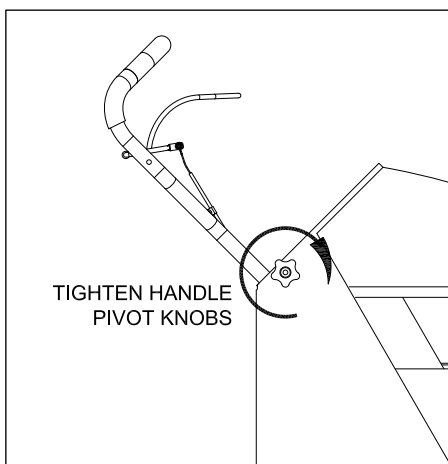

## Fuse

The machine's electrical circuit is protected by a fuse, which stops the flow of current in the event of a circuit overload. Once a fuse blows, it must be replaced. If the overload that caused the fuse to fail is still present, the new fuse will fail and the problem must be corrected. **DO NOT** bypass any fuse. The ignition fuse is located on the side of the starter switch panel.

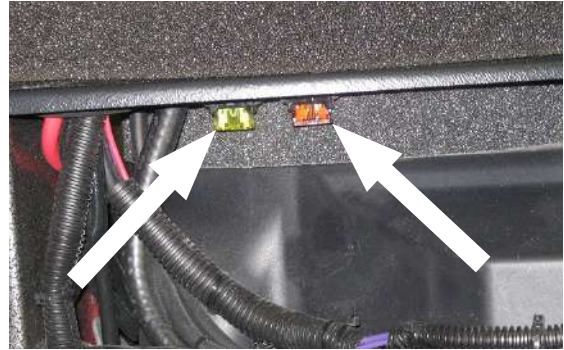

## Dust Bag

1. Remove the dust bag cover by lifting upward on the back of the cover.



2. Pull the dust bag off the dust tube, keeping the closed end pulled downward to prevent spillage.



3. Empty bag by rubbing or gently tapping on sides, in a downward motion, to loosen soil trapped on sides of bag. For heavy soil, turn bag inside out to clean.
4. Check the dust tube for debris and clear if needed.
5. Reinstall dust bag by working the elastic band over the lip of the rubber grommet.
6. Stretch the dust bag towards rear of machine and orientate with the zipper facing downward.
7. Feed the dust bag into the bottom of the cover and lower the cover back into place.

## How the Machine Works

This machine is a propane burnisher that has a pad driver that is belt driven directly from the engine crank shaft.

## Pre-Operation Checklist

- Check the engine oil level. Add oil if needed. Refer to *Maintenance*.
- Inspect the engine dust filter and clean off any debris or dust buildup. Refer to *Maintenance*.
- Inspect the burnishing pad and replace, if necessary. Refer to *Maintenance*.
- Inspect the pad holder for cracks or damage! Replace if necessary. Refer to *Maintenance*.

**WARNING!** A DAMAGED PAD HOLDER ROTATING AT HIGH SPEEDS MAY BE AN EXTREME HAZARD IF IT SHOULD DISINTEGRATE.

- Inspect air filter. Clean or replace if necessary. A dirty air filter could lead to elevated levels of carbon monoxide. Refer to *Maintenance*.
- Inspect the drive belt. Replace if necessary. Refer to *Maintenance*.
- Check the machine for leaks or loose fasteners.

## LP Fuel Cylinder

This machine uses the 20 lb (9.1 kg) capacity cylinder, which meets the D.O.T. 4E240 standards. These cylinders are also listed by UL. In addition, the steel cylinder meets European TPED specifications and is CE compliant. Filling should be done ONLY by a qualified propane dealer. A properly filled cylinder should not exceed 80% of the rated capacity. Do not overfill the cylinder or use a liquid withdraw cylinder on the machine. The use of a liquid withdraw cylinder on a vapor withdraw system could freeze the regulator and create a fire hazard.

### Only Use a Vapor Cylinder!

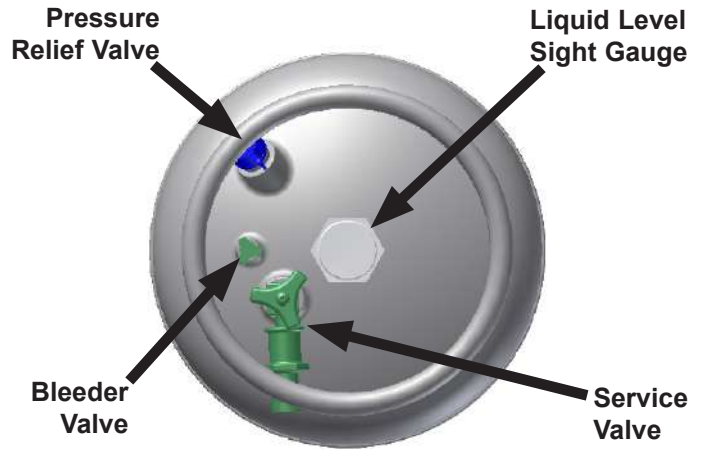
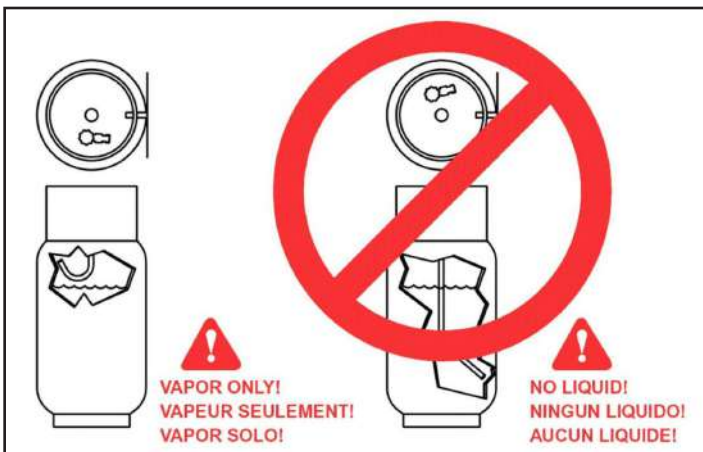

## Installing the LP Cylinder

1. Before bringing a propane cylinder indoors, always check it for over-filling.

**CAUTION!** Always connect or change cylinders in a well ventilated area.

2. Place the tank on the machine and secure with the retaining strap. Remove slack by pulling on the loose end of the strap and secure back to strap. Connect the fuel hose coupling to the service valve by turning clockwise. **“HAND TIGHTEN ONLY.”** Make sure coupling is not cross threaded and check for leakage by noting any propane odors immediately after cylinder is connected. (It is sometimes easier to install if the connection to the service valve is made before strapping the cylinder in place.)



**CAUTION!** Always open service valve slowly to allow pressure to equalize in hoses. Opening quickly may cause the flow check valve to engage, limiting fuel flow.



3. To remove the cylinder, reverse procedure.

## Starting the Machine

1. Check oil and fuel levels.
2. Check and clean engine dust filter.

**CAUTION!** *Never run continuously for more than 1 hour without cleaning or changing engine dust filter.*

3. Check carburetor air filter. Change if necessary. (See “Scheduled Maintenance”)
4. Turn propane service valve counterclockwise to open.

**CAUTION!** *Always open service valve slowly to allow pressure to equalize in hoses. Opening quickly may cause the flow check valve to engage, limiting fuel flow.*

5. Allow machine to tilt backward (pad off floor) and move throttle to SLOW (IDLE) position.
6. With the engine throttle lever in the idle position, engage the starter by turning the key switch to the starting position for approximately 5 seconds. If the engine does not start, release the key switch for 10 seconds, then try to start again in another 5 seconds.
7. After the engine has started, move the throttle forward approximately halfway and allow the engine to warm up for approximately 30 seconds.

**WARNING!** *Catalytic mufflers require a few minutes to warm up before effectively removing harmful emissions. Make sure of proper ventilation during this warm-up period!*

## Idling and Stopping the Machine

**DANGER!** *Allowing the engine to idle excessively will increase carbon monoxide emissions!*

To stop the engine, close the service valve on the fuel cylinder by turning it clockwise (the engine will stop when the fuel in the lines is used up). Once the engine stops, turn the ignition switch off.

## Burnishing

1. After engine has started, allow approximately 30 seconds for the engine to warm up.
2. Advance the throttle to operating speed.
3. Lower the burnishing head to the floor while moving the machine forward slowly.

**CAUTION!** *Do not run the burnisher without moving the machine. If the machine is allowed to run in one spot, damage to the floor may occur.*

4. To stop burnishing, push down on handle to raise the burnishing head off the floor.

**CAUTION! DO NOT** *add weight to the burnisher head.*

**CAUTION! DO NOT** *lift up on the handle to add pressure while burnishing.*

**NOTE:** *To not comply with any of the CAUTION! statements could cause the engine to overheat and/or damage the pad holder or drive components.*

**NOTE:** *It is recommended to start burnishing on the right side of the aisle, turn and come back down the aisle in the opposite direction, overlapping the previous path slightly. Continue this pattern until the floor area to be burnished has been covered with the last pass being on the right side of the machine. The forward speed is generally at normal walking speed.*

5. When done burnishing, push the machine to the desired location. Turn off the LP cylinder service valve. When the fuel is depleted and the engine stops, turn the key switch OFF.
6. Remove the LP cylinder and store properly. Refer to *Refueling and Storage of Fuel Cylinders*.

## Machine Troubleshooting

Problem	Possible Cause	Solution
Engine is hard to start	Propane cylinder is not properly connected.	Check connection and open service valve slowly.
	Battery is weak.	Charge battery or replace.
	Oil level is to low.	Check the oil level and add if needed.
	Insufficient vacuum.	Place the engine throttle in the idle "slow" position.
		Check the regulator vacuum hose for breaks, pinched hose, or a bad connection.
	Coil air gap out of adjustment.	Adjust coil air gap (Check FS481V Service Manual). Contact an APEC Certified Technician.
	Spark plug or head bolts loose.	Retorque (Check FS481V Service Manual). Contact an APEC Certified Technician.
Head gasket blown or valves need adjusting	Replace head gasket, adjust valves and replace if necessary (Check FS481V Service Manual). Contact an APEC Certified Technician.	
Engine will not start	Propane cylinder is empty.	Install properly filled cylinder.
	Oil level is to low.	Check the oil level and add if needed.
	Machine is in the pad change position.	Lower the machine to operating position.
	Main fuse is blown.	Inspect fuse and if blown replace
	Insufficient vacuum.	Place the engine throttle in the idle "slow" position.
		Check the regulator vacuum hose for breaks, pinched hose, or a bad connection.
	Head gasket blown or valves need adjusting	Replace head gasket, adjust valves and replace if necessary (Check FS481V Service Manual). Contact an APEC Certified Technician.
	Wires broken or disconnected.	Reconnect or replace wires. Contact an APEC Certified Technician.
	Coil(s) defective.	Replace coil(s) (Check FS481V Service Manual). Contact an APEC Certified Technician.
	Spark plug gap is incorrect.	Adjust gap to 0.025" (.64mm)
Spark plug defective.	Replace spark plug.	
	If the light is on, turn the key switch off and wait 30 seconds. Try again.	
Engine lacks power	Insufficient vacuum.	Place the engine throttle in the idle "slow" position.
		Check the regulator vacuum hose for breaks, pinched hose, or a bad connection.
	Dirty air filter(s).	Clean or replace the primary filter (paper element).
		Clean or repalce the secondary filter (foam element).
	Governor out of adjustment or malfunctioning.	Adjust governor and replace if necessary (Check FS481V Service Manual). Contact an APEC Certified Technician.
	Head gasket leaking.	Replace head gasket (Check FS481V Service Manual). Contact an APEC Certified Technician.
	No compression.	Worn piston ring(s) and/or cylinder head(s) require replacement (Check FS481V Service Manual). Contact an APEC Certified Technician.
Fuel mixture is to lean.	Check and adjust fuel mixture if necessary. Contact an APEC Certified Technician.	
Valves need adjusting or replacing.	Adjust valves (Check FS481V Service Manual). Contact an APEC Certified Technician.	
Smell or burned rubber	Belt out of adjustment.	Check the automatic tensioner
Machine vibrates	Loose fasteners.	Check the engine, tensioner, spindle, and pad holder fasteners. Tighten any fasteners that may be loose.
	Pad is not centered on the pad holder.	Remove pad and re-center on padholder. Replace the pad with a new pad if necessary.
	Padholder is out of balance.	Remove pad holder from the macine and clean both sides. Check for cracks or tears. Replace if necessary.
Machine is burnishing too aggressively	Wheels are adjusted to far back.	Move both wheels forward in the wheel bracket.
	Improper pads.	Only use recommended burnishing pads.
Machine pulls to one side	Bent wheel bracket.	Replace wheel bracket.
	Wheel is worn or a bad bearing.	Replace wheel.
	Wheels are adjusted to far back.	Move both wheels forward in the wheel bracket.
Engine stops running	Propane cylinder is empty.	Install properly filled cylinder.
	Engine oil level is to low.	Check the oil level and add if needed.
	Dirty air filter.	Clean both filters or replace if necessary.
		Check close loop vacuum line.
	SafeSense shut the machine down	Clean all filters and replace if necessary.
		Check for any loose wiring or fuel line connections.
Service machine and check the fuel settings. Contact an APEC Certified Technician		
Clutch will not engage	Loose Connection	Check all of the wiring for a bad connection or broken wire
	Clutch is bad	Replace clutch if necessary. Contact an APEC Certified Technician
Dust collection not working properly	Dust collection bad is not collecting dust	Empty dust bag
		Check the dust scoop and/or the dust tube to see if there is an obstruction.
	Skirt is not sealing to the floor	Skirt is bent or damaged. Replace if necessary.
		Adjust the skirt to fit tightly against the seal, but still able to move freely.
		Check wear edge on bottom of the skirt and replace if necessary.

# Maintenance

## Scheduled Maintenance

Operation	Interval							
	Daily	First 8 Hrs.	Every 50 Hrs.	Every 100 Hrs.	Every 200 Hrs.	Every 300 Hrs.	Every 400 Hrs.	Every 500 Hrs.
Check & add engine oil	●							
Check for loose or lost fasteners	●							
Check for oil leakage	●							
Inspect fuel hose and connections	●							
Clean engine dust filter	●							
Inspect pad holder	●							
Change engine oil		●	●					
Change engine oil filter		●		●				
Check & clean air cleaner paper element				●				
Check & clean air cleaner foam element				●				
Inspect battery and battery connections				●				
Replace air cleaner paper element					●			
Replace air cleaner foam element							●	
Inspect, clean, & re-gap spark plugs. Replace if necessary				●				
Check & adjust valve clearance.* Retorque heads.*						●		
Clean & lap valve seating surface.*						●		
Check engine emissions*								●
Clean cooling fins			●					
Inspect drive belt				●				
Inspect burnishing head assembly			●					
Replace drive belt	As Required							
* Check FS481V Service Manual. Contact Amano Pioneer Eclipse Certified Technician.								

## Oil Level Inspection

1. Push machine to level surface.
2. Turn off LP cylinder and remove it.
3. Clean area around the oil gauge before removing it.
4. Remove the oil gauge and wipe it with a clean cloth.



5. The machine should be in an upright level position. If necessary, place a block under the back of the machine or apply weight to the front of the deck to maintain an upright, level position.
6. Insert the oil gauge into the tube, but do not tighten the oil gauge.
7. Check the oil level. It should be between the "FULL" and "ADD" marks on the oil gauge.

**NOTE:** If the oil level is near or below the "ADD" mark, remove the oil gauge and add enough engine oil to bring oil level to the "FULL" mark. (Use only SH or SJ SAE30 Oil)

**NOTE:** If the oil level is too high, remove the excess oil by loosening the oil drain valve.

**CAUTION!** Do not fill above the "FULL" mark. Excess oil will cause a smoking condition and may cause the engine to overheat.

## Oil Change

1. Change the oil after the first 8 hours of operation and every 50 hours thereafter.
2. Start and warm the engine so the oil will drain easily and completely. Push machine to a level surface. Stop the engine.
3. Turn off LP cylinder and remove it.
4. Locate the drain hose inside the bulkhead compartment. Lower the drain hose from the clamp and remove the cap on the end of oil drain hose



5. Place a suitable container under the end of the oil drain hose.
6. Slowly turn the valve counter-clockwise, until the oil starts to drain.

**WARNING!** Be careful with hot oil being drained. It may be hot enough to cause severe burns.



**NOTE:** In order for the oil to drain, it may be necessary to loosen the oil fill cap.

8. When the oil has finished draining, close the drain valve and place cap back on the end of the valve.
9. Remove oil cap and add clean SH or SJ SAE 30 oil. Use 1.6 U.S. qt. (1.5 L) when the filter is not changed and 1.8 U.S. qt. (1.7 L) when filter is changed.
10. Screw in oil gauge. Reconnect the LP cylinder to the fuel hose.
11. Run the engine at low idle for 2 minutes. Check for leaks around the engine.
12. Stop the engine. Check the oil level (see *Oil Level/Inspection* section).

## Oil Filter Replacement

1. Place a suitable container underneath the oil filter.
2. Using a strap wrench or oil filter wrench, remove the oil filter. Turn the filter counter-clockwise to remove it.
3. Apply a thin coat of new oil or grease to the oil filter seal (-B-).
4. Install the new filter (-A-) (**Part #: KA490657007**) by turning it clockwise.

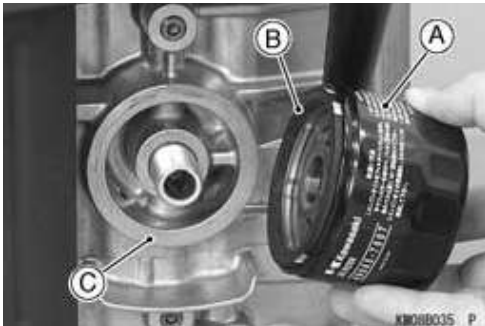

5. Turn the filter until the seal contacts the mounting surface (-C-) of the engine. Then, turn the filter "BY HAND" 3/4 turn more.
6. Reconnect the LP cylinder to the fuel hose.
7. Run the engine at low idle for 2 minutes. Check for leaks around the engine.

## Spark Plug Inspection and Replacement

1. Turn off LP cylinder and remove it.
2. Pull spark plug cap off of spark plug.
3. Remove spark plug by turning counter-clockwise and inspect it.

**NOTE:** If the plug is oily or has carbon build up on it, clean the plug using a high flash-point solvent and a wire brush or other suitable tool.

**NOTE:** If the spark plug electrodes are corroded or damaged, or if the insulator is cracked, replace the plug. Use Only **Part #: KA920702112**. **DO NOT use any other spark plug!**

4. Measure the gap with a wire-type thickness gauge. The correct gap is .025 in (.635 mm). If the gap is incorrect, carefully bend the side electrode with a suitable tool to obtain the correct gap.

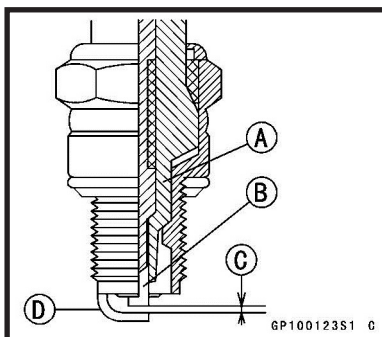

- A: Insulator
- B: Center Electrode
- C: Plug Gap
- D: Side Electrode

## Hood Removal

The hood must be removed to gain access to the LP fuel regulator, starter solenoid, starting battery, and electrical components. Remove the two knobs, one of each side of the hood. With the knobs removed pull toward the front of the machine and lift the hood out of place.



## Air Filter Inspection and Replacement

1. Push machine to level surface.
2. Turn off LP cylinder and remove it.
3. Turn the two knobs 1/4 turn counter-clockwise and remove the filter cover.
4. Loosen clamp that retains filter and remove the air filter.



**CAUTION!** Do not wash the air cleaner filters. Do not oil the air filters. Do not use pressurized air to clean the air filters.

5. Inspect both primary and secondary air filters. If necessary, clean primary filter by lightly tapping and wipe seal ends with a clean cloth. If primary filter cannot be cleaned, is bent, or damaged, it must be replaced. (**Part #: KA110130752**) If secondary filter is dirty, do not attempt to clean it. Replace it with a new filter (**Part #: KA110137046**).
6. Check the intake hose for cracks or damage.
7. Install filters and replace cover.

### Engine Dust Filter

1. The engine dust filter should be cleaned each hour and after each use by shaking out the dust and then rinsing with mild detergent. The filter can also be vacuumed with a wet-dry vacuum.
2. Squeeze out the excess water (*Do Not Wring*).
3. Allow the filter to air dry.

**NOTE:** Failure to maintain a clean engine filter will cause the engine to overheat. Also, it may cause the exhaust emissions to elevate to harmful levels. If necessary, replace with (**Part #: MP373400**).



### Valve Clearance & Re-torque Heads:

Refer to Kawasaki's FS481V service manual.

### Valve Seating:

Refer to Kawasaki's FS481V service manual.

### Head Bolt Maintenance

Refer to Kawasaki's FS481V service manual.

### Cooling Fin Maintenance

- A. Remove blower housing and any other shrouds.
- B. Clean the cooling fins as necessary using compressed air or pressure washer.
- C. Reinstall all housings and shrouds.

### Inspect Fuel Hose and Connections

1. Push machine to level surface.
2. Turn off LP cylinder and remove it.
3. Remove the hood that covers the battery and regulator.
4. Inspect hoses for abrasions and other signs of wear. Replace all worn or damaged hoses.
5. Check for gas leaks by spreading a soapy water solution around all connections while the LP cylinder is reconnected and the service valve is turned ON.



5. If a leak is detected, turn off the LP cylinder. If the leak is in a hose, replace it. If the leak is at a fitting, loosen and clean it. Apply pipe-sealing compound and re-tighten it.
6. Recheck for leaks using a soapy water solution. If leaks persist at fittings, replace them and recheck with a soapy water solution once more.

## **Inspect Pads and Pad Holders**

1. Push machine to level surface.
2. Turn off LP cylinder and remove it.
3. Rock the machine back by lifting up the front of the machine until it rests on the handle grips. (See "Rok-Bak & Pad Change" section.)
4. Remove centering device and inspect the pad. If the pad has worn less than 1/4" (6 mm), replace it.
5. Inspect the pad holder for cracks or damage. If the pad holder does not have any damage proceed to step 9.

**WARNING!** A damaged pad holder rotating at a high rate of speed may be an extreme hazard if it should come apart.

6. If the pad holder needs to be removed, a 3/4" wrench will be required. Locate the wrench flats on top of the spindle shaft. With the spindle shaft secure, turn the pad holder counter clockwise until it is free of the spindle shaft.
7. Save the washer and/or spacer that is on the spindle shaft. Be sure they are in place when the pad holder is re-installed.
8. When threading the pad holder onto the spindle shaft, use the wrench to keep the shaft from turning. Be sure the pad holder is tight before proceeding.
9. Secure the pad with the centering device.
10. Lower the machine.

## **Belt Maintenance**

1. Push machine to level surface.
2. Turn off LP cylinder and remove it.
3. Place the machine in the Rok-Bak position (See "Rok-Bak & Pad Change" section) by lifting up on the front of the machine until it rests on the handle grips.
4. Rotate the pad drive and inspect the belt.
5. If cracks or excessive wear is present, the belt needs to be replaced.
6. To check for the proper tightness, squeeze the belt together. The belt should depress between 1/4" (0.6 cm) and 1/2" (1.3 cm).

## **Belt Replacement**

**(21") Part #: MP8070**

**(24") Part #: MP8049**

**(28") Part #: MP272900**

1. Remove the pad holder by holding the end of the shaft on the top of the machine with a 3/4" wrench and turn the pad holder counter-clockwise.
2. Remove the four bolts that retain the pulley cover to the deck liner.
3. Use the 3/4" wrench to turn the end of the spindle shaft on top of the machine while removing the old belt from the spindle pulley.
4. Finish removing the belt from the engine pulley, if necessary.
5. Check engine pulley for correct alignment with the spindle pulley. Check hardware attaching pulleys for proper tightness.
6. Install the new belt onto the engine pulley.
7. Reinstall the new belt onto the spindle pulley using the 3/4" wrench to turn the spindle clockwise. Make sure the belt is correctly placed on the idler pulley.
8. Reinstall the pulley cover.
9. Add Anti-Seize compound to the threads of the spindle shaft and reinstall the pad holder onto the spindle shaft.
10. Lower the machine to the burnishing position.
11. Check belt for correct operation. Check all hardware for proper tightness.

## Battery Maintenance

The battery supplied with this machine is a sealed, absorbed glass mat (AGM), maintenance free type. It never needs servicing. When battery replacement is necessary (**Part #: MP362200**).

1. Push machine to level surface.
2. Turn off LP cylinder and remove it.



3. Remove the hood that covers the battery and regulator.
4. Disconnect the "BLACK" negative battery cable first.
5. Then disconnect the "RED" positive battery cable (**DO NOT** disconnect the "RED" cable first).
5. Loosen battery-retaining strap.
6. Lift out old battery and replace with new battery.
7. Secure battery with battery-retaining strap.
8. Connect the "RED" positive battery cable first (**DO NOT** connect the "BLACK" cable first).
9. Connect the BLACK negative battery cable.

**NOTE:** Dispose of old battery in the proper manner. Most auto parts stores accept used batteries for recycling.

### **PROPOSITION 65 WARNING**

- Battery posts, terminals, and related accessories contain lead and lead compounds, chemicals known to the State of California to cause cancer and reproductive harm.
- Batteries also contain other chemicals known to the State of California to cause cancer.
- Wash hands after handling.

## Machine Storage

Only authorized, trained personnel should have access to propane cylinders and machines.

1. Remove propane fuel cylinder when not in use and store it outside in a storage cage in accordance with NFPA Handbook 58 CAN/CGAB149.2. Do not release or bleed propane inside the building. Please consult your local Fire Marshal to ensure that you are in compliance with local fire codes.
2. Store machine away from objects that may fall and damage it.
3. Never store machine or fuel cylinders near an open flame or heat-producing device.
4. Make sure machine is cleaned properly before storing.
5. Never store machine with cylinders installed, or store spare cylinders in an enclosed van or trailer.
6. Store machine in a dry location, temperature not to exceed 120°F (50°C).

## Repacking the Machine

Refer to *Unpacking* and repack the machine using original packing materials and container. Store machine in a dry location, temperature not to exceed 120°F (50°C).

## Transporting the Machine

When transporting a propane powered floor machine with the fuel cylinder installed, the cylinder should be securely fastened with the service valve closed and the machine should be secured in the vehicle. Any propane fuel cylinders not installed should be securely fastened to avoid movement and damage. Never store machine with cylinder installed or store spare cylinders in an enclosed van or trailer. It is a good practice to check propane cylinders for overfilling before transporting them. If overfilled, correct before loading them in the vehicle by venting the excess propane outside in a safe area using the bleeder valve.

## Machine Specifications

<u>Starting:</u>	12VDC Battery
<u>Deck:</u>	Cast Aluminum
<u>Sound Level:</u>	< 89 dB(A)
<u>Vibration:</u>	Less than 2.5 m/s <sup>2</sup>
<u>Engine:</u>	Kawasaki FS481V, 603cc Air Cooled
<u>Engine Speed:</u>	Idle - 1800-2000 rpm High Idle - 3400-3500 rpm
<u>Engine Oil:</u>	SAE 30 w/ API Service SH or SJ
<u>Engine Oil Capacity:</u>	Filter not removed - 1.6qt (1.5L) Filter removed - 1.8qt (1.7L)
<u>Engine Primary Air Filter (Paper Element):</u>	KA110130752
<u>Engine Air Pre-Cleaner (Foam Element):</u>	KA110137046
<u>Spark Plug:</u>	KA920702112
<u>Spark Plug Gap:</u>	0.025 in. (0.635 mm)
<u>LP Cylinder Type:</u>	20lb (9.1 kg) Vapor Withdraw

### 21" Machines

Pad Size:	21" (53.3 cm)
Pad Speed:	2000 RPM
Width:	24.5" (62.2 cm)
Length:	58" (148 cm)
Height:	44.5" (113 cm)
Weight:	242 lbs (w/o cylinder) (110 kg) (w/ Clutch & Dust Collection)

### 24" Machines

Pad Size:	24" (61.0 cm)
Pad Speed:	1800 RPM
Width:	27.5" (69.9 cm)
Length:	61" (155 cm)
Height:	44.5" (113 cm)
Weight:	248 lbs (w/o cylinder) (113 kg) (w/ Clutch & Dust Collection)

### 28" Machines

Pad Size:	28" (71.1 cm)
Pad Speed:	1500 RPM
Width:	31.5" (80 cm)
Length:	65.5" (156.2 cm)
Height:	44.5" (104 cm)
Weight:	262 lbs (w/o cylinder) (119 kg) (w/ Clutch & Dust Collection)



# Electrical Schematic

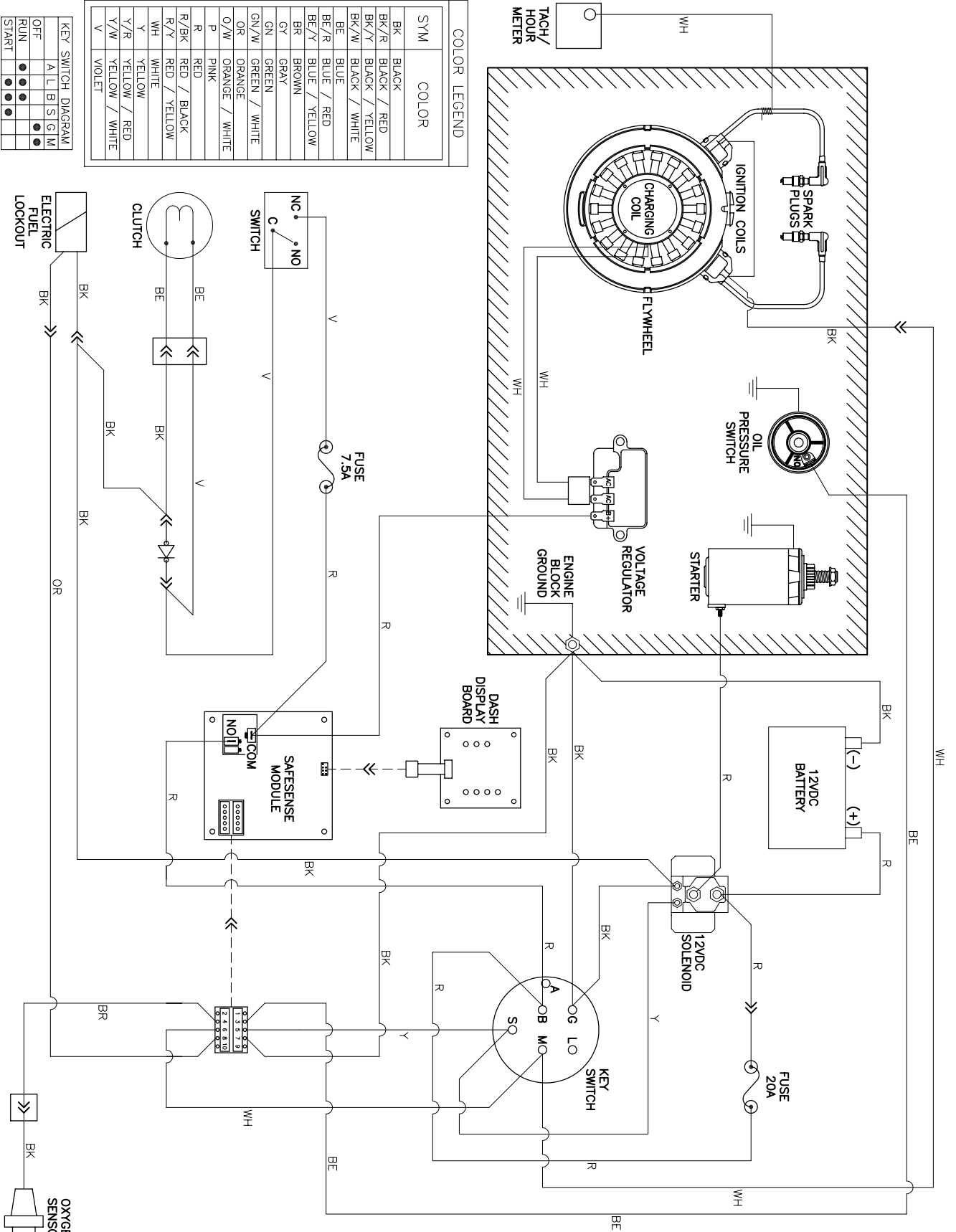

SYM	COLOR
BK	BLACK
BK/R	BLACK / RED
BK/Y	BLACK / YELLOW
BK/W	BLACK / WHITE
BE	BLUE
BE/R	BLUE / RED
BE/Y	BLUE / YELLOW
BR	BROWN
GN	GREEN
GN/W	GREEN / WHITE
OR	ORANGE
O/W	ORANGE / WHITE
P	PINK
R	RED
R/BK	RED / BLACK
R/Y	RED / YELLOW
WH	WHITE
Y	YELLOW
Y/R	YELLOW / RED
Y/W	YELLOW / WHITE
V	VIOLET

KEY SWITCH DIAGRAM	A	L	B	S	G	M
OFF	●	●	●	●	●	●
RUN	●	●	●	●	●	●
START	●	●	●	●	●	●

RF035200

120210

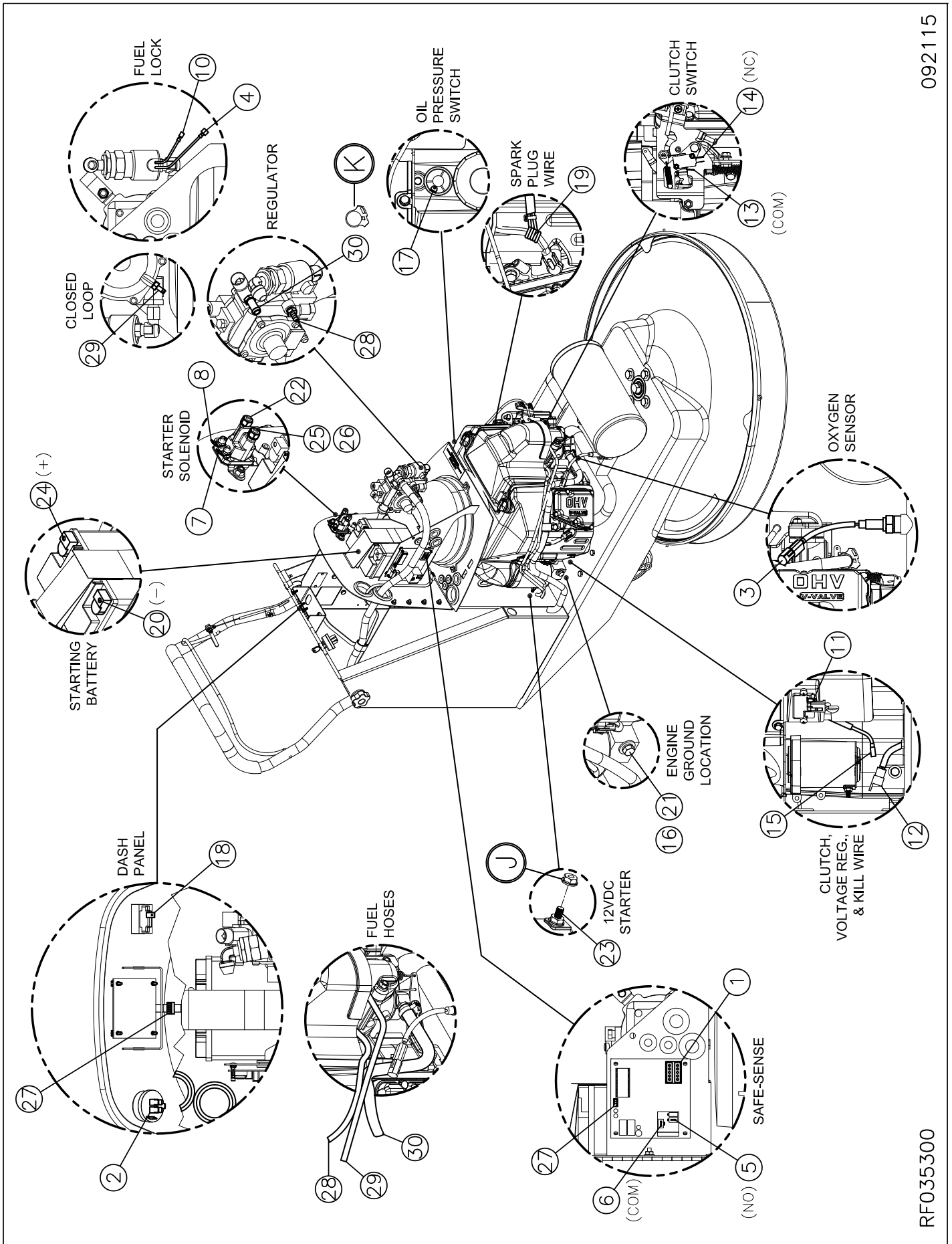

092115

RF035300

## Connections (Continued)

RF035300

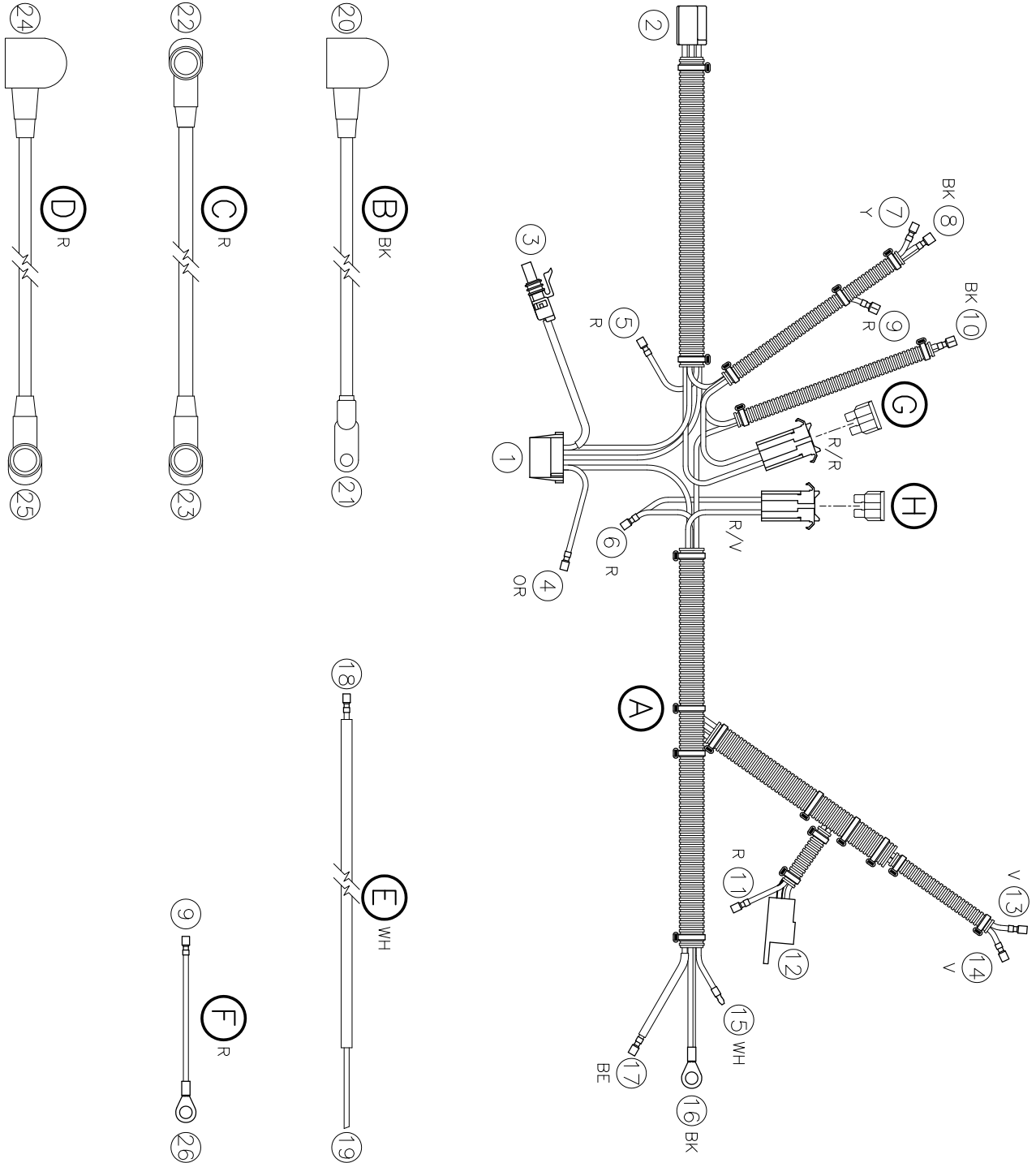

092115

Item	Ref. No.	Description	Qty	Item	Ref. No.	Description	Qty
A	MP379200	HARNESS, WIRING	1	F	MP354900	WIRE, SOLENOID, BATTERY	1
B	MP2012	CABLE, BATTERY, NEG	1	G	SS2570	FUSE, 20A	1
C	MP379400	CABLE, BATTERY, POS., 34"	1	H	MP043000	FUSE, 7.5A	1
D	MP379500	CABLE, BATTERY, POS., 14"	1	J	NB9545	NUT, FLANGE, 1/4"	1
E	MP379300	HARNESS, TACH/HOUR, 63"	1	K	NB7282	CLAMP, HOSE	1

# Engine Assembly

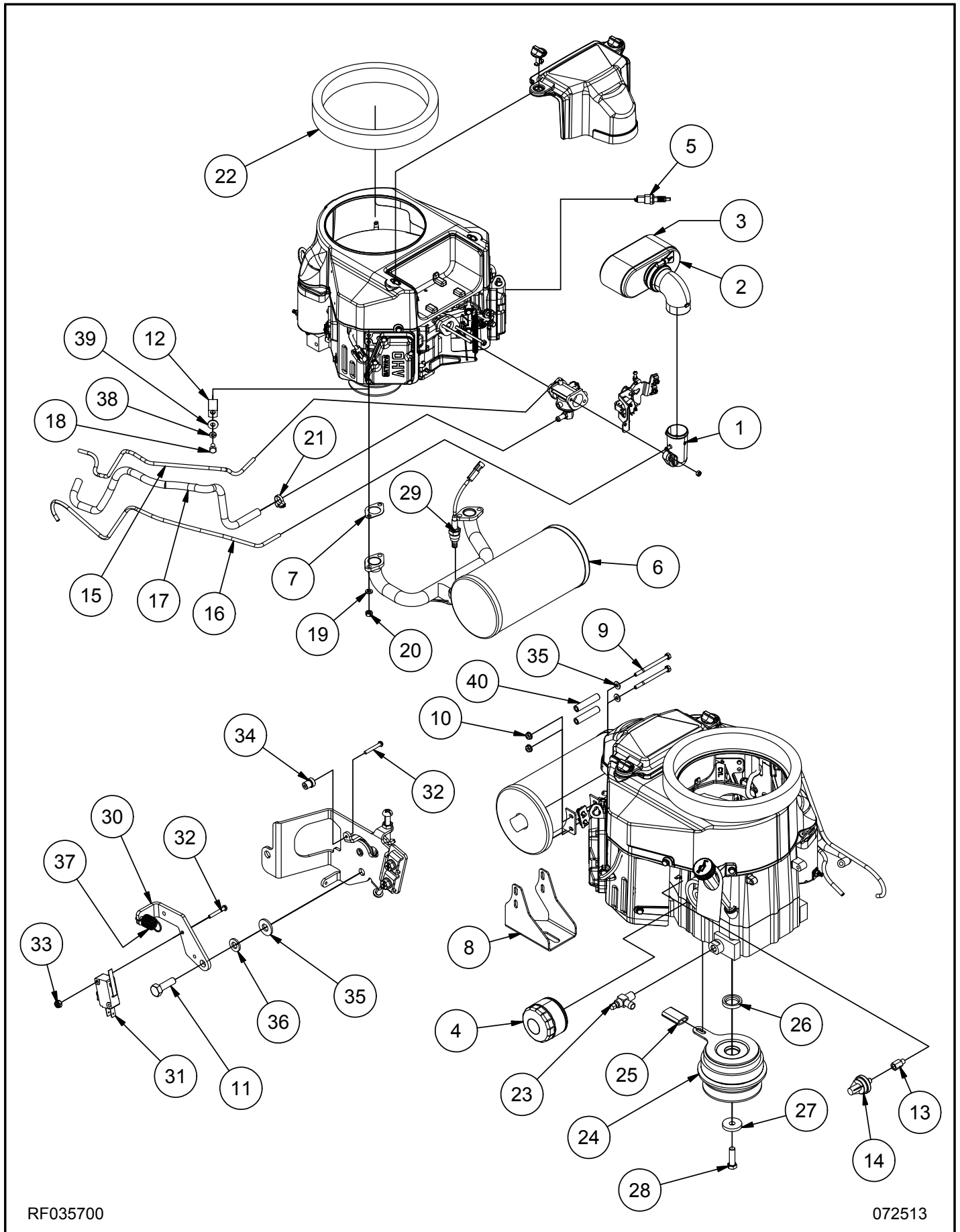

RF035700

072513

## Engine Assembly (continued)

<u>Item</u>	<u>Ref. No.</u>	<u>Description</u>	<u>Qty</u>	<u>Item</u>	<u>Ref. No.</u>	<u>Description</u>	<u>Qty</u>
1	KA160600742	PIPE, INTAKE	1	21	NB7282	CLAMP, HOSE	1
2	KA110130752	ELEMENT, FILTER, AIR	1	22	MP043100	SEAL, INTAKE, AIR	1
3	KA110137046	PRECLEANER, AIR	1	23	MP072300	VALVE, DRAIN, OIL	1
4	KA490657007	FILTER, OIL	1	24	MP4787	CLUTCH, ASM.	1
5	KA920702112	PLUG, SPARK, NGK, BPR4ES	1	25	MP4790	TUBING, NEOPRENE	2"
6	MP364900	MUFFLER, CATALYST	1	26	MP371700	SPACER, 1.02" ID	2"
7	KA110607016	GASKET, MUFFLER	2	27	MP4805	SPACER, BOTTOM, CLUTCH	1
8	MP455601	BRACE, MUFFLER	1	28	NB005800	BOLT, HEX, 7/16" X 1-1/2"	1
9	NB068500	BOLT, HEX, 1/4" X 3-1/2"	2	29	MP466500	SENSOR, OXYGEN	1
10	NB9545	NUT, FLANGE, 1/4"	2	30	MP452101	BRACKET, SWITCH	1
11	NB6012	BOLT, HEX, M6 X 20	1	31	MP318400	SWITCH, MICRO, 12V	1
12	NB8130	CLAMP, 3/4" ID	1	32	NB9625	SCREW, #4 X 3/4"	1
13	MP044800	ADAPTER, 1/8" NPT	1	33	NB007000	NUT, LOCK, #4	3
14	MP028700	SWITCH, PRESSURE, OIL	1	34	MP452200	SPACER, THROTTLE, #4	2
15	NB2460	HOSE, VACUUM, 5/32"	37"	35	NB3350	WASHER, FLAT, 1/4"	1
16	NB2460	HOSE, VACUUM, 5/32"	45"	36	NB6110	WASHER, LOCK, 1/4"	3
17	NB2470	HOSE, FUEL, 3/8"	40"	37	MP452300	SPRING, EXTENSION	1
18	NB065000	BOLT, HEX, M8 X 16	1	38	NB6111	WASHER, LOCK, 5/16"	1
19	KA461DA0800	WASHER, LOCK, M8	4	39	NB9267	WASHER, FLAT, 5/16"	1
20	KA922107027	NUT, HEX, M8	4	40	MP455900	SPACER, 1/4" ID	2

# Bulkhead Assembly

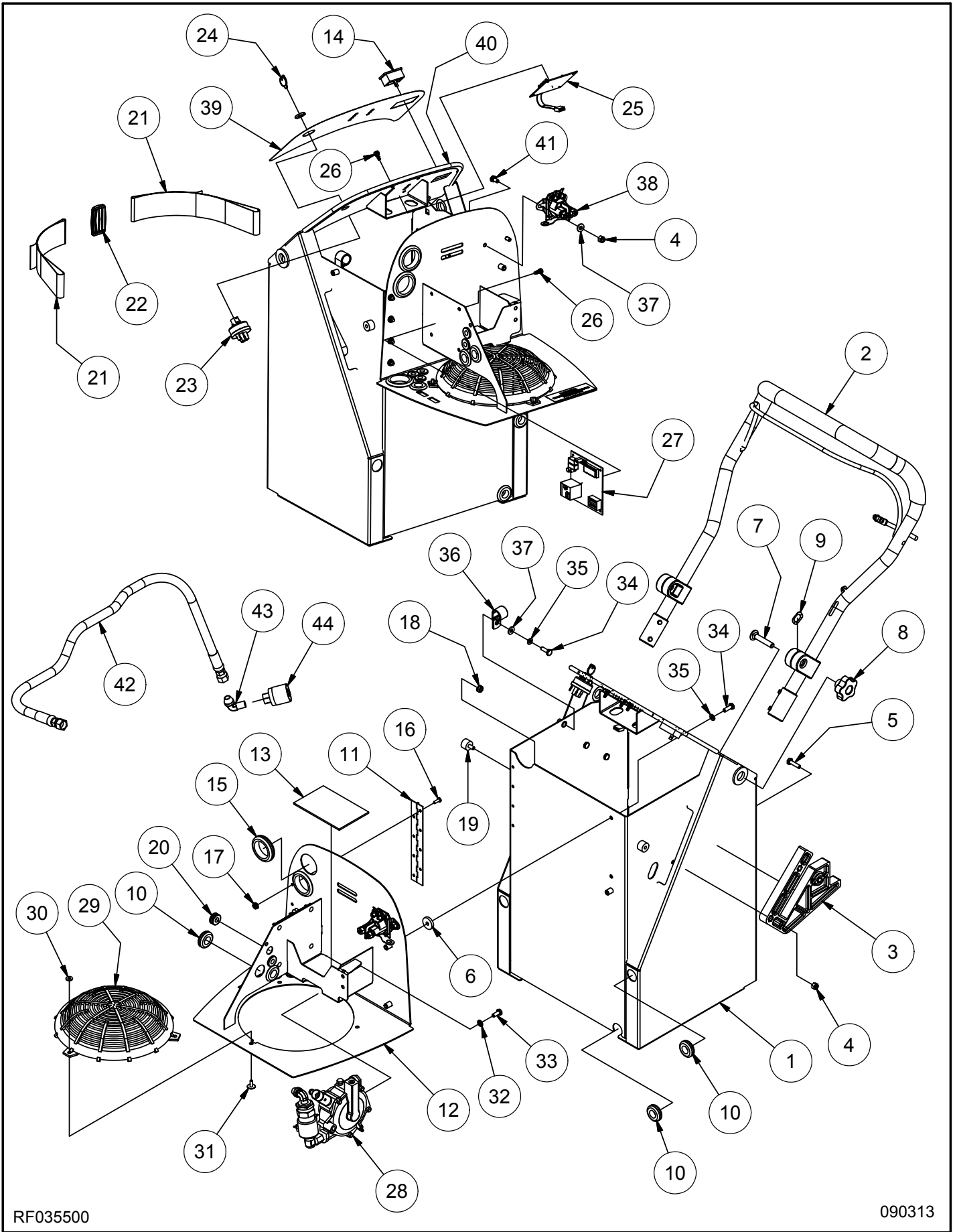

RF035500

090313

**Bulkhead Assembly (continued)**

<u>Item</u>	<u>Ref. No.</u>	<u>Description</u>	<u>Qty</u>	<u>Item</u>	<u>Ref. No.</u>	<u>Description</u>	<u>Qty</u>
1	MP377300	BULKHEAD, ASM.	1	23	MP199000	SWITCH, IGNITION	1
2	MP375500	HANDLE, ASM.	1	24	KC4834001	KEY, SWITCH, IGNITION	1
3	MP039300	PLATE, LOCK, HANDLE	2	25	MP042800	BOARD, DISPLAY	1
4	NB3275	NUT, LOCK, 1/4"	8	26	NB012500	SPACER, BOARD	8
5	NB6530	BOLT, HEX, 1/4" X 1"	6	27	MP161200	MODULE, SAFESENSE	1
6	MP373100	WASHER, RUBBER	2	28	MP375600	REGULATOR, ASM.	1
7	NB010100	BOLT, CARRIAGE, 3/8" X 2"	2	29	KA550200900	GUARD, SCREEN, FS481V	1
8	RV005100	KNOB, HANDLE	2	30	NB9645	WASHER, FLAT, #10	3
9	NB011400	WASHER, WAVE	2	31	NB021000	RIVET, 3/16"	3
10	NB009900	GROMMET, 11/16" ID	5	32	MX1115	WASHER, STAR, 1/4"	2
11	MP373600	HINGE, 7.5" X 1.25"	1	33	NB003200	BOLT, HEX, 1/4" X 5/8"	2
12	MP377200	TRAY, BATTERY, ASM.	1	34	NB019100	BOLT, HEX, 1/4" X 3/4"	4
13	MP373800	PAD, BATTERY	1	35	NB6110	WASHER, LOCK, 1/4"	4
14	MP280400	METER, HOUR / TACH	1	36	NB8130	CLAMP, 3/4"	2
15	NB6514	GROMMET, 1-1/2" ID	3	37	NB3350	WASHER, FLAT, 1/4"	4
16	NB034100	SCREW, #10 X 1/2"	8	38	MP367100	SOLENOID, STARTER, 12V	1
17	NB9510	NUT, FLANGE, #10	8	39	MP390400	DECAL, PANEL, CONTROL	1
18	NB9845	NUT, KEPS, 1/4"	2	40	IN1015	TRIM, BATTERY TRAY	24"
19	IN3510	MOUNT, TYPE S, 1/4"	2	41	NB015700	BOLT, HEX, 1/4" X 5/8"	2
20	NB009800	GROMMET, 3/8" ID	5	42	MP373300	HOSE, FUEL, LP, 3/4", ASM.	1
21	MP368100	STRAP, 2" X 23"	2	43	MP4330	FITTING, ELBOW	1
22	MP367600	SLIDE, STRAP, 2"	1	44	MP4500	COUPLER, REGO	1

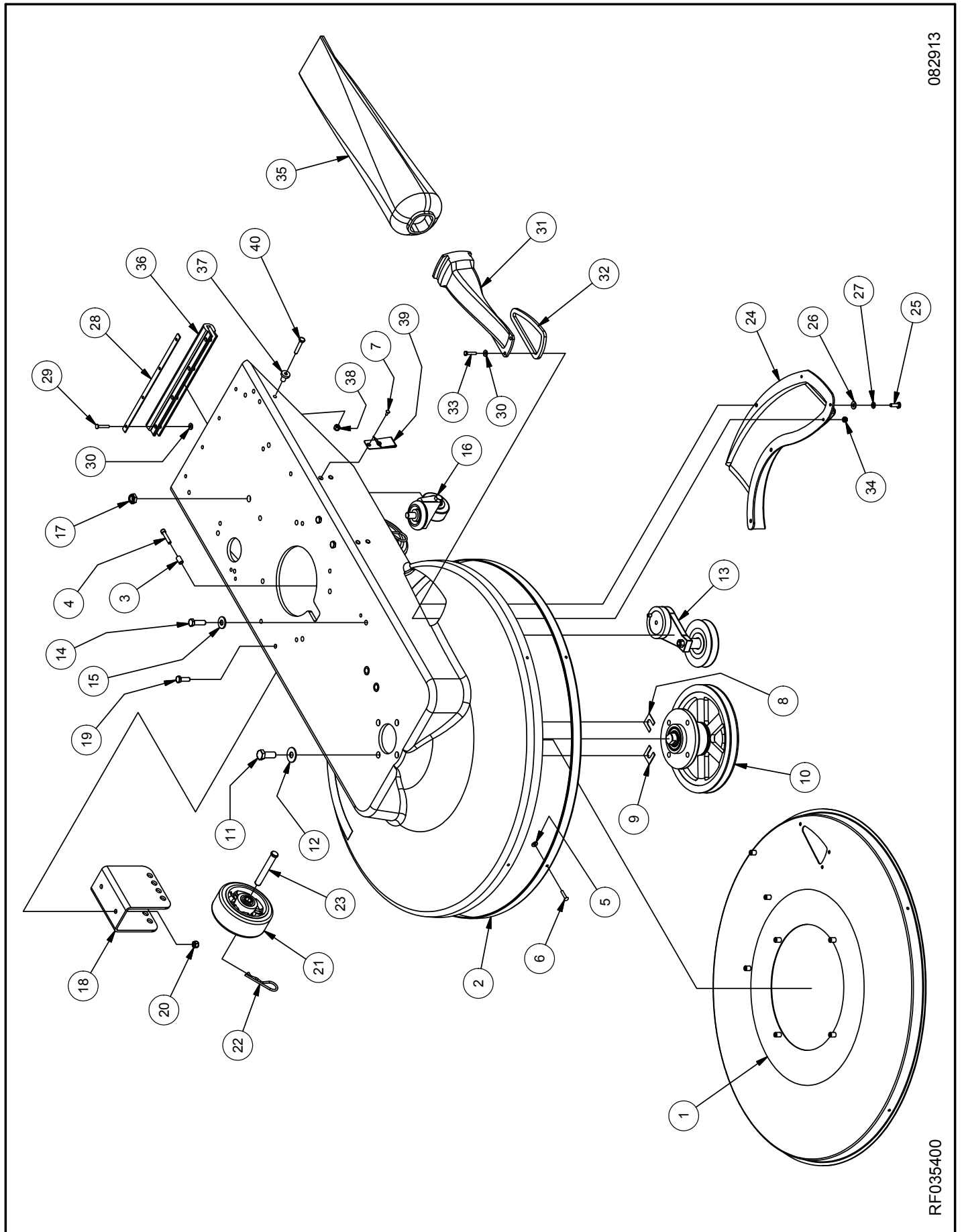

082913

RF035400

**Old Deck Assembly (continued)**

<u>Item</u>	<u>Ref. No.</u>	<u>Description</u>	<u>Qty</u>	<u>Item</u>	<u>Ref. No.</u>	<u>Description</u>	<u>Qty</u>
1A	MP066801	LINER, 28", ASM.	1	19	NB6545	BOLT, HEX, 5/16" X 1"	4
1B	MP073300	LINER, 24", ASM.	1	20	NB3265	NUT, LOCK, 5/16"	4
1C	MP376200	LINER, 21", ASM.	1	21	MP352600	WHEEL, 5" X 2"	2
2A	MP8300	HOOK, VELCRO, 1" (28")	98"	22	LX2105	CLIP, HITCH PIN	2
2B	MP8300	HOOK, VELCRO, 1" (24")	85"	23	NB053400	PIN, CLEVIS, 1/2" X 3-1/2"	2
2C	MP8300	HOOK, VELCRO, 1" (21")	74"	24A	MP064800	SCOOP, VAC, 28"	1
3	MP139900	BUSHING, STEEL	1	24B	MP064700	SCOOP, VAC, 24"	1
4	NB038800	BOLT, SH, 1/4" X 1-1/4"	1	24C	MP064600	SCOOP, VAC, 21"	1
5	NB9645	WASHER, FLAT, #10	5	25	NB019100	BOLT, HEX, 1/4" X 3/4"	3
6	NB020600	RIVET, 3/16" X 1/2"	5	26	NB3350	WASHER, FLAT, 1/4"	3
7	NB045000	RIVET, 5/32"	4	27	NB6110	WASHER, LOCK, 1/4"	3
8	MP197100	SHIM, CAMBER, 1/32"	1	28	MP336200	STRAP, BUMPER	1
9	MP197000	SHIM, CAMBER, 1/16"	1	29	NB063400	RIVET, 3/16" X 1.00"	4
10A	MP447700	SPINDLE, 9.25", ASM. (28")	1	30	NB9645	WASHER, FLAT, #10	7
10B	MP7235	SPINDLE, 7.25", ASM. (24")	1	31	MP067600	TUBE, DUST	1
10C	MP107700	SPINDLE, 6.75", ASM. (21")	1	32	MP065200	SEAL, TUBE, DUST	1
11	NB6864	BOLT, HEX, 1/2" X 1-1/4"	4	33	NB063300	SCREW, HEX, #10 X 1"	3
12	NB9269	WASHER, FLAT, 7/16"	4	34	NB9735	NUT, LOCK, #10	3
13	MP071800	TENSIONER, BELT	1	35	MP124700	BAG, DUST	1
14	NB6044	BOLT, HEX, 3/8" X 1-1/4"	1	36	MP371400	BUMPER, ROK-BAK	1
15	NB3450	WASHER, FLAT, 3/8"	1	37	MP079800	STUD, SUPPORT	1
16	MP012801	CASTER, 2-1/2"	1	38	NB3275	NUT, LOCK, 1/4"	1
17	NB003100	NUT, JAM, HEX, 1/2"	1	39	NB017200	CLIP, COVER	2
18	MP371501	BRACKET, WHEEL	2	40	NB9000	BOLT, HEX, 1/4" X 1-12"	1

# Old Main Assembly

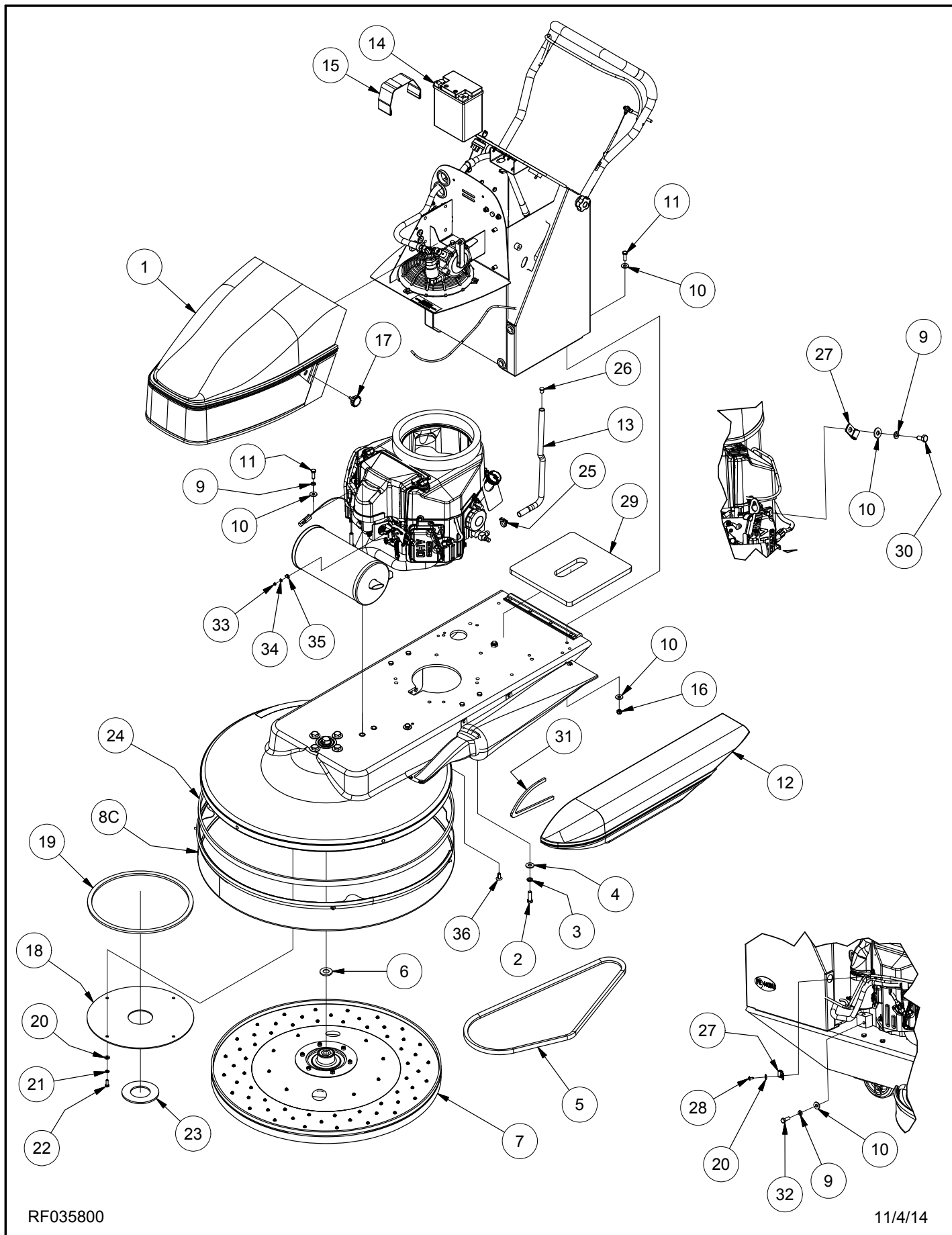

RF035800

11/4/14

**Old Main Assembly (continued)**

<u>Item</u>	<u>Ref. No.</u>	<u>Description</u>	<u>Qty</u>	<u>Item</u>	<u>Ref. No.</u>	<u>Description</u>	<u>Qty</u>
1	MP375800	COVER, BATTERY, ASM.	1	18A	MP068600	COVER, PULLEY, 28"	1
2	NB6044	BOLT, HEX, 3/8" X 1-1/4"	3	18B	MP073400	COVER, PULLEY, 24"	1
3	MX1075	WASHER, LOCK, 3/8"	3	18C	MP125300	COVER, PULLEY, 21"	1
4	NB3450	WASHER, FLAT, 3/8"	3	19	MP075200	FOAM, 1/2" X 38"	1
5A	MP272900	BELT, BX-57 (28")	1	20	NB3350	WASHER, FLAT, 1/4"	5
5B	MP8049	BELT, BX-49 (24")	1	21	NB6110	WASHER, LOCK, 1/4"	4
5C	MP8070	BELT, BX-46 (21")	1	22	NB019100	BOLT, HEX, 1/4" X 3/4"	4
6	MP195300	SPACER, BEARING	1	23	MP065100	SEAL, SPINDLE	1
7A	MP032500	PAD HOLDER, 28", ASM.	1	24A	MP139600	FELT, BLACK (28")	8 FT
7B	MP047500	PAD HOLDER, 24", ASM.	1	24B	MP139600	FELT, BLACK (24")	7 FT
7C	MP095200	PAD HOLDER, 21", ASM.	1	24C	MP139600	FELT, BLACK (21")	6.25 FT
8A	MP139400	SKIRT, 28", ASM.	1	25	NB7282	CLAMP, HOSE	1
8B	MP139300	SKIRT, 24", ASM.	1	26	NB1621	PLUG, CAP	1
8C	MP139200	SKIRT, 21", ASM.	1	27	NB8125	CLAMP, 1/4"	2
9	NB6111	WASHER, LOCK, 5/16"	4	28	NB064900	SCREW, #10 X 1/2"	1
10	NB9267	WASHER, FLAT, 5/16"	12	29	MP470300	PAD, TANK	1
11	NB6545	BOLT, HEX, 5/16" X 1"	6	30	NB065000	BOLT, HEX, M8 X 16	1
12	MP067400	COVER, BAG, DUST	1	31	MP075200	FOAM, 1/2" X 38"	1
13	MP4515	TUBING, DRAIN, OIL	20"	32	NB065100	BOLT, HEX, M8 X 25	1
14	MP362200	BATTERY, 12V	1	33	NB007000	NUT, LOCK, #4	1
15	MP368100	STRAP, 2" X 23"	1	34	NB007100	WASHER, FLAT, #6	1
16	NB3265	NUT, LOCK, 5/16"	4	35	NB012300	WASHER, LINKAGE	1
17	MP372600	KNOB, 1/4" X 1/2"	2	36	NB065800	PLUG, HOLE, 5/16"	1

# Deck Assembly

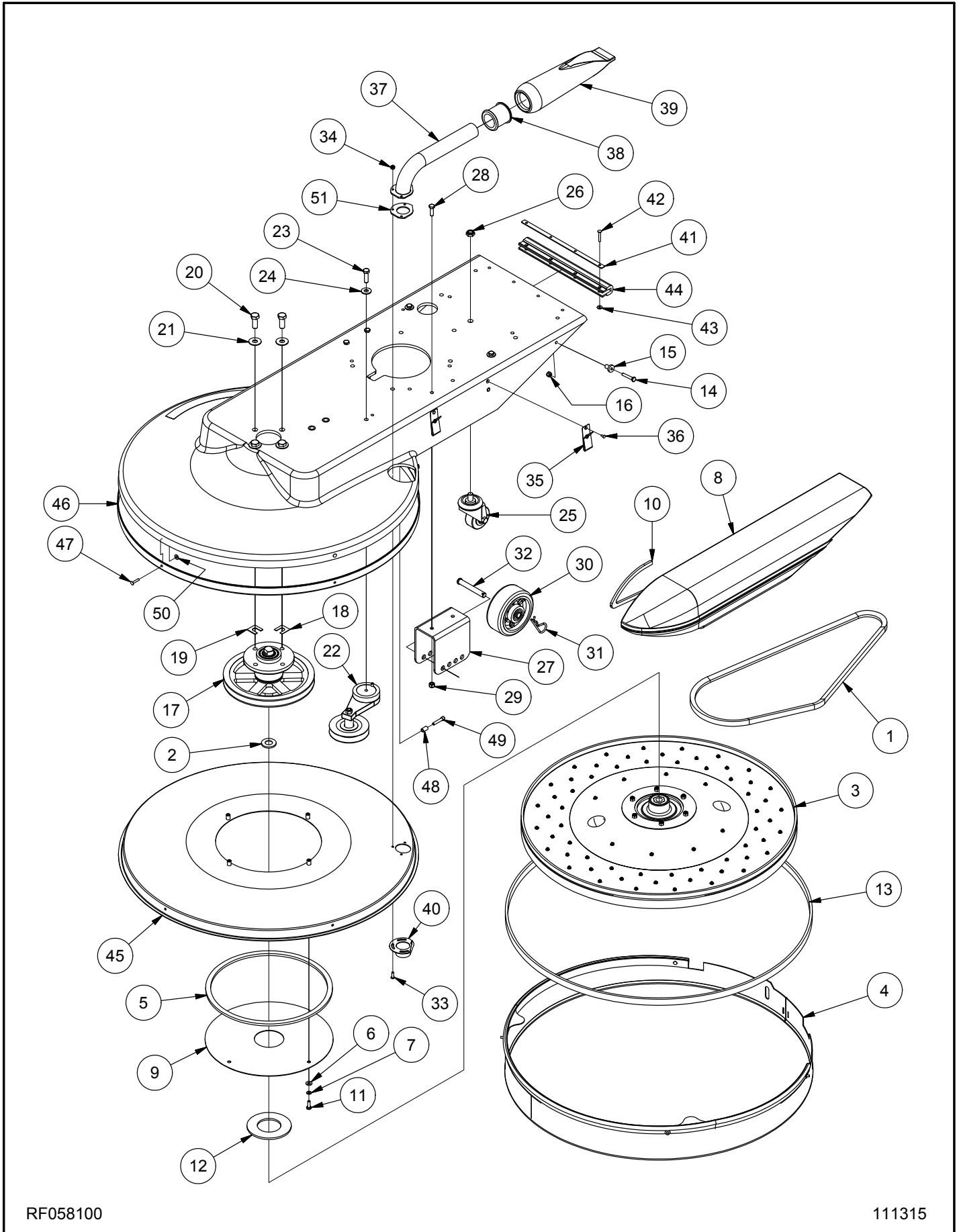

RF058100

111315

**Deck Assembly (continued)**

<u>Item</u>	<u>Ref. No.</u>	<u>Description</u>	<u>Qty</u>	<u>Item</u>	<u>Ref. No.</u>	<u>Description</u>	<u>Qty</u>
1A	MP272900	BELT, BX-57 (28")	1	23	NB6044	BOLT, HEX, 3/8" X 1-1/4"	1
1B	MP8049	BELT, BX-49 (24")	1	24	NB3450	WASHER, FLAT, 3/8"	1
1C	MP8070	BELT, BX-46 (21")	1	25	MP012801	CASTER, 2-1/2"	1
2	MP195300	SPACER, BEARING	1	26	NB003100	NUT, LOCK, JAM, 1/2"	1
3A	MP032500	PAD HOLDER, 28", ASM.	1	27	MP371501	BRACKET, WHEEL, 5" X 2"	2
3B	MP047500	PAD HOLDER, 24", ASM.	1	28	NB6545	BOLT, HEX, 5/16" X 1"	4
3C	MP095200	PAD HOLDER, 21", ASM.	1	29	NB3265	NUT, LOCK, 5/16"	4
4A	MP139400	SKIRT, 28", ASM.	1	30	MP352600	WHEEL, 5" X 2"	2
4B	MP139300	SKIRT, 24", ASM.	1	31	LX2105	PIN, HITCH CLIP	2
4C	MP139200	SKIRT, 21", ASM.	1	32	NB053400	PIN, CLEVIS, 1/2" X 3-1/2"	2
5	MP075200	FOAM, 1/2" X 38"	1	33	NB049200	SCREW, BH, #10 X 5/8"	3
6	NB3350	WASHER, FLAT, 1/4"	4	34	NB9735	NUT, LOCK, #10	3
7	NB6110	WASHER, LOCK, 1/4"	4	35	NB017200	CLIP	2
8	MP067400	COVER, BAG	1	36	NB045000	RIVET, 5/32"	4
9A	MP068600	COVER, PULLEY, 28"	1	37	MP469500	TUBE, DUST	1
9B	MP073400	COVER, PULLEY, 24"	1	38	MP469400	GROMMET, 1.5" ID X 2" OD	1
9C	MP125300	COVER, PULLEY, 21"	1	39	MP469300	BAG, DUST	1
10	MP075200	FOAM, 1/2" X 38"	1	40	MP467600	SCOOP, VACUUM	1
11	NB019100	BOLT, HEX, 1/4" X 3/4"	4	41	MP336200	STRAP, BUMPER	1
12	MP065100	SEAL, SPINDLE	1	42	NB063400	RIVET, 3/16" X 1"	4
13A	MP139600	FELT, BLACK (28")	8 FT	43	NB9645	WASHER, FLAT, #10	4
13B	MP139600	FELT, BLACK (24")	7 FT	44	MP371400	BUMPER, ROK-BAK	1
13C	MP139600	FELT, BLACK (21")	6.25 FT	45A	MP481000	LINER, SHROUD, 28", ASM.	1
14	NB9000	BOLT, HEX, 1/4" X 1-1/2"	1	45B	MP494700	LINER, SHROUD, 24", ASM.	1
15	MP079800	STUD, SUPPORT, COVER	1	45C	MP477500	LINER, SHROUD, 21", ASM.	1
16	NB3275	NUT, LOCK, 1/4"	1	46A	MP8300	HOOK, VELCRO, 1" (28")	9 FT
17A	MP447700	SPINDLE, 9.25", ASM.	1	46B	MP8300	HOOK, VELCRO, 1" (24")	8 FT
17B	MP7235	SPINDLE, 7.25", ASM.	1	46C	MP8300	HOOK, VELCRO, 1" (21")	7 FT
17C	MP107700	SPINDLE, 6.75", ASM.	1	47	NB020600	RIVET, 3/16" X 1/2"	5
18	MP197100	SHIM, 1/32"	1	48	MP139900	BUSHING, SKIRT	1
19	MP197000	SHIM, 1/16"	1	49	NB038800	BOLT, SH, 1/4" X 1-1/4"	1
20	NB6864	BOLT, HEX, 1/2" X 1-1/4"	4	50	NB9645	WASHER, FLAT, #10	5
21	NB9269	WASHER, FLAT, 7/16"	4	51	MP496500	GASKET, DUST TUBE	1
22	MP071800	TENSIONER, BELT	1				

# Main Assembly

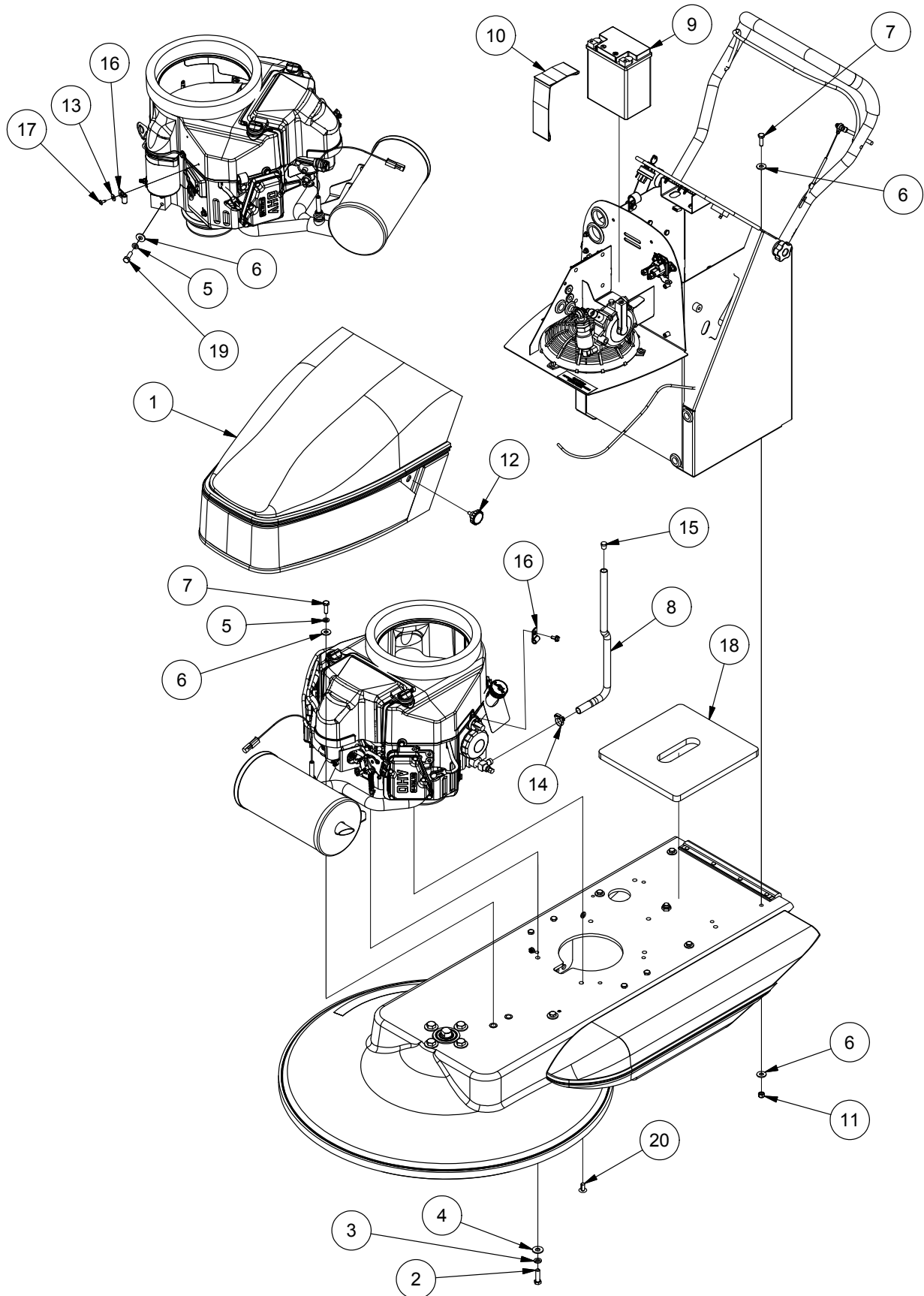

RF058200

080615

## Main Assembly (continued)

<u>Item</u>	<u>Ref. No.</u>	<u>Description</u>	<u>Qty</u>
1	MP375800	HOOD, BLACK, ASM.	1
2	NB6044	BOLT, HEX, 3/8" X 1-1/4"	3
3	MX1075	WASHER, LOCK, 3/8"	3
4	NB3450	WASHER, FLAT, 3/8"	3
5	NB6111	WASHER, LOCK, 5/16"	3
6	NB9267	WASHER, FLAT, 5/16"	11
7	NB6545	BOLT, HEX, 5/16" X 1"	6
8	MP4515	TUBING, OIL DRAIN	20"
9	MP362200	BATTERY, 12, AGM	1
10	MP368100	STRAP, 2" X 23"	1
11	NB3265	NUT, LOCK, 5/16"	4
12	MP372600	KNOB, 1/4" X 1/2"	2
13	NB3350	WASHER, FLAT, 1/4"	1
14	NB7282	CLAMP, HOSE	1
15	NB1621	PLUG, CAP	1
16	NB8125	CLAMP, 1/4"	2
17	NB064900	SCREW, #10 X 1/2"	1
18	MP470300	PAD, TANK	1
19	NB065100	BOLT, HEX, M8 X 25	1
20	NB065800	PLUG, HOLE, 5/16"	1

Regulator, Handle, & Hood Assembly

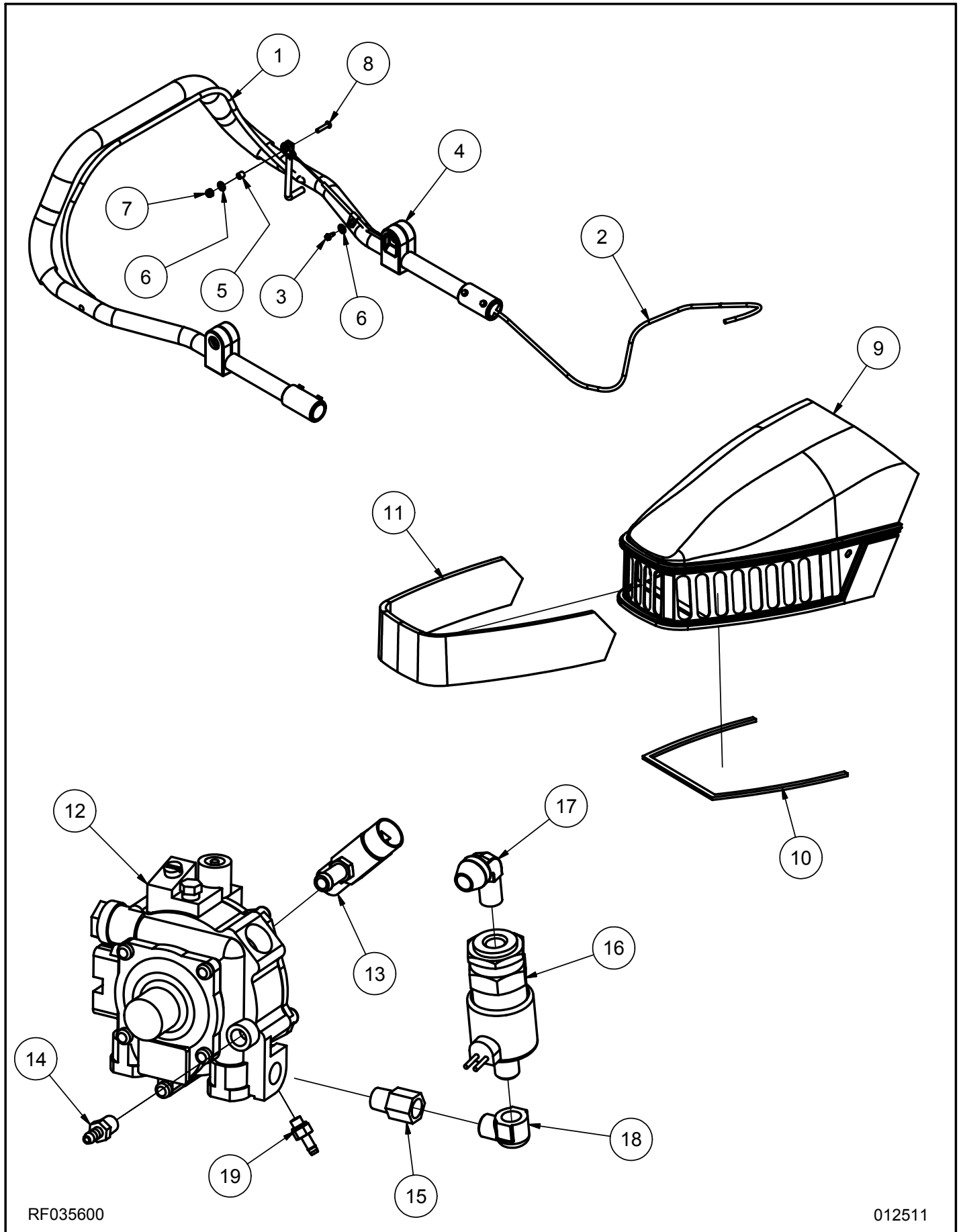

RF035600

012511

**Regulator, Handle, & Hood Assembly (continued)**

<u>Item</u>	<u>Ref. No.</u>	<u>Description</u>	<u>Qty</u>
1	MP042000	BAIL, BACK	1
2	MP106500	CABLE, CONTROL, THROTTLE	1
3	NB4382	SCREW, #8 X 1/2"	5
4	MP050500	BLOCK, GUIDE, CABLE	1
5	NB028300	BUSHING, CABLE	1
6	NB9645	WASHER, FLAT, #10	2
7	NB9735	NUT, LOCK, #10	1
8	NB049100	SCREW, #10 X 7/8"	1
9	MP375800	HOOD, BLACK, ASM.	1
10	MP075200	FOAM, 1/2" X 38"	1
11	MP373400	FILTER, AIR, HOOD	1
12	SA026300	REGULATOR, LP	1
13	MP017900	ADJUSTMENT, FUEL, ASM.	1
14	MP019500	FITTING, HB, 1/8" NPT	1
15	MP027100	FITTING, EXTENSION	1
16	MP317500	FUELOCK, ASM.	1
17	MP4330	FITTING, ELBOW	1
18	MP027200	FITTING, ELBOW, 1/4" NPT	1
19	MP371100	FITTING, HB, 1/4-28	1

Skirt & Pad Holder Assembly

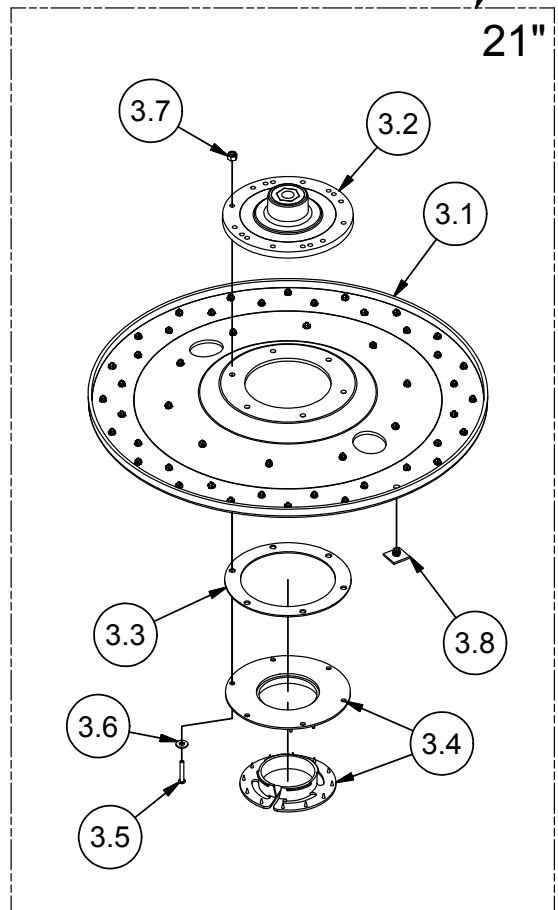
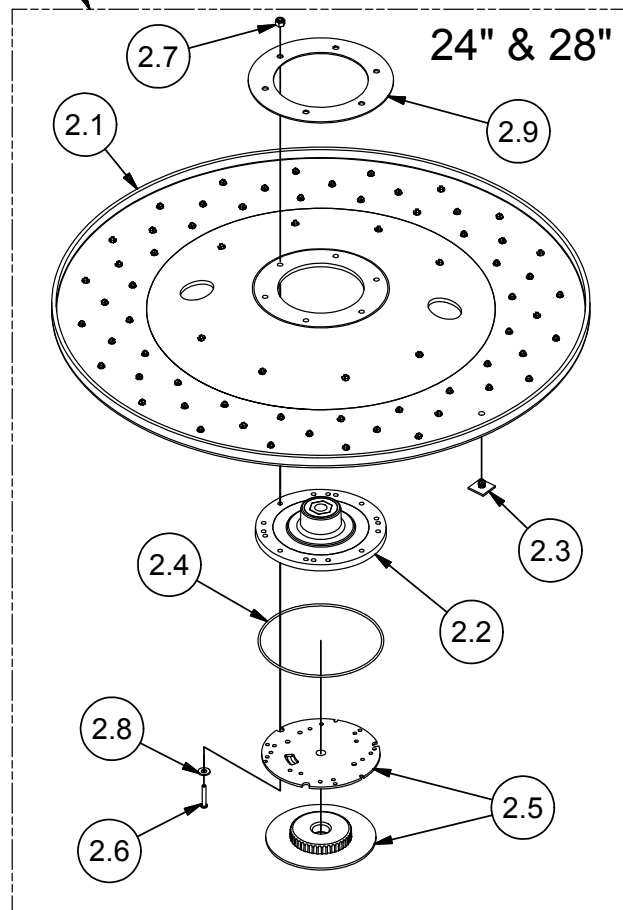
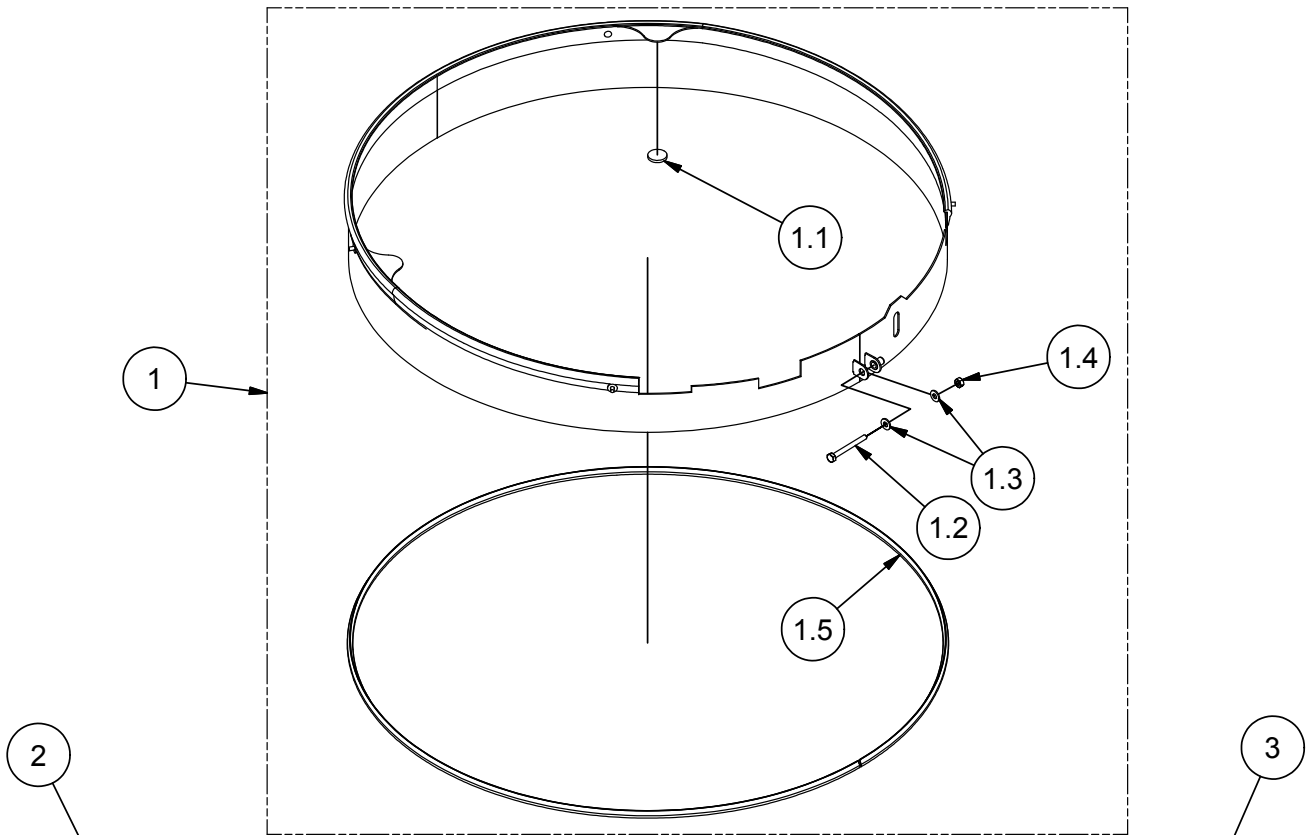

RF034900

102810

**Skirt & Pad Holder Assembly (continued)**

<u>Item</u>	<u>Ref. No.</u>	<u>Description</u>	<u>Qty</u>
<b>SKIRT</b>			
1A	MP139400	SKIRT, 28", ASM.	1
1B	MP139300	SKIRT, 24", ASM.	1
1C	MP139200	SKIRT, 21", ASM.	1
1.1	MP140000	FELT, DOT	2
1.2	NB050600	BOLT, HEX, 1/4" X 2-1/2"	1
1.3	NB3350	WASHER, FLAT, 1/4"	2
1.4	MX1045	NUT, HEX, 1/4"	1
1.5A	MP139800	EDGING, WEAR (28")	8.14 FT
1.5B	MP139800	EDGING, WEAR (24")	7.10 FT
1.5C	MP139800	EDGING, WEAR (21")	6.03 FT
<b>28" &amp; 24" PAD HOLDER</b>			
2A	MP032500	PAD HOLDER, 28", ASM.	1
2B	MP047500	PAD HOLDER, 24", ASM.	1
2.1A	SA004000	PAD HOLDER, 28" W/ STUDS	1
2.1B	SA007800	PAD HOLDER, 24" W/ STUDS	1
2.2	MP195800	FLEXI, W/O LIP, YELLOW	1
2.3A	MP8310	STUDS, VELCRO (28")	68
2.3B	MP8310	STUDS, VELCRO (24")	76
2.4	MP066300	RING, SPACER	1
2.5	MP012700	RETAINER, PAD (SCREW IN)	1
2.6	NB9319	SCREW, BH, 1/4" X 1-1/4"	6
2.7	NB3275	NUT, LOCK, 1/4"	6
2.8	NB3350	WASHER, FLAT, 1/4"	6
2.9	MP196300	RING, RELIEF	1
<b>21" PAD HOLDER</b>			
3	MP095200	PAD HOLDER, 21", ASM.	1
3.1	SA003900	PAD HOLDER, 21" W/ STUDS	1
3.2	MP195800	FLEXI, W/O LIP, YELLOW	1
3.3	MP081300	RING, RELIEF, 21"	1
3.4	MP8505	RETAINER, PAD (SNAP IN)	1
3.5	NB9319	SCREW, BH, 1/4" X 1-1/4"	6
3.6	NB3350	WASHER, FLAT, 1/4"	6
3.7	NB3275	NUT, LOCK, 1/4"	6
3.8	MP8310	STUDS, VELCRO (21")	50

# Small Off-Road Engine Certification Warranty Form

## Emission Control Warranty Statement

### Your Warranty Rights and Obligations

The California Air Resources Board and Amano Pioneer Eclipse Corporation is pleased to explain the emissions control system's warranty on your 2016 small off-road engine. In California, new equipment that use small off-road engines must be designed, built, and equipped to meet the State's stringent anti-smog standards. Amano Pioneer Eclipse Corporation must warrant the emissions control system on your small off-road engine for the period listed below provided there has been no abuse, neglect or improper maintenance of your equipment. Your emissions control system may include parts such as: carburetor's or fuel injection system, ignition system, catalytic converters, fuel tanks, valves, filters, clamps, connectors, and other associated components. Also, included may be hoses, belts, connectors, sensors, and other emission-related assemblies. Where a warrantable condition exists, Amano Pioneer Eclipse Corporation will repair your small off-road engine at no cost to you including diagnosis, parts and labor.

### Manufacturer's Warranty Coverage

This emissions control system is warranted for two years. If any emissions-related part on your equipment is defective, the part will be repaired or replaced by Amano Pioneer Eclipse Corporation.

### Owner's Warranty Responsibilities

- (a) As the small off-road engine owner, you are responsible for performance of the required maintenance listed in your owner's manual. Amano Pioneer Eclipse Corporation recommends that you retain all receipts covering maintenance on your small off-road engine, but Amano Pioneer Eclipse Corporation cannot deny warranty solely for the lack of receipts or your failure to ensure the performance of all scheduled maintenance.
- (b) As the small off-road engine owner, you should however be aware that Amano Pioneer Eclipse Corporation may deny you warranty coverage if your small off-road engine or a part has failed due to abuse, neglect, or improper maintenance or unapproved modifications.
- (c) You are responsible for presenting your small off-road engine to an Amano Pioneer Eclipse Corporation distribution center or service center as soon as the problem exists. The warranty repairs should be completed in a reasonable amount of time, not to exceed 30 days. If you have a question regarding your warranty coverage, you should contact Amano Pioneer Eclipse Corporation at 1-800-367-3550.

### Defects Warranty Requirements

- (A) The warranty period begins on the date the engine or equipment is delivered to an ultimate purchaser.
- (B) **General Emissions Warranty Coverage.** Amano Pioneer Eclipse Corporation as the manufacturer of each small off-road engine or equipment must warrant to the ultimate purchaser and each subsequent owner that the engine or equipment is:
  - (1) Designed, built, and equipped so as to conform with all applicable regulations adopted by the Air Resources Board; and
  - (2) Free from defects in materials and workmanship that causes the failure of a warranted part for a period of two years.
- (C) The warranty on emissions-related parts will be interpreted as follows:
  - (1) Any warranted part that is not scheduled for replacement as required maintenance in the written instructions required by subsection (D) must be warranted for the warranty period defined in Subsection (B2). If any such part fails during the period of warranty coverage, it must be repaired or replaced by the manufacturer according to Subsection (C4) below. Any such part repaired or replaced under the warranty must be warranted for the remaining warranty period.
  - (2) Any warranted part that is scheduled only for regular inspection in the written instructions required by subsection (D) must be warranted for the warranty period defined in Subsection (B2). A statement in such written instructions to the effect of "repair or replace as necessary" will not reduce the period of warranty coverage. Any such part repaired or replaced under warranty must be warranted for the remaining warranty period.

- (3) Any warranted part that is scheduled for replacement as replacement as required maintenance in the written instructions required by subsection (D) must be warranted for the period of time prior to the first scheduled replacement point for that part. If the part fails prior to the first scheduled replacement, the part must be repaired or replaced by the engine manufacturer according to Subsection (C4) below. Any such part repaired or replaced under warranty must be warranted for the remainder of the period prior to the first scheduled replacement point for the part.
- (4) Repair or replacement of any warranted part under the warranty must be performed at no charge to the owner at a warranty station.
- (5) Notwithstanding the provisions of Subsection (C4) above, warranty services or Repairs must be provided at all manufacturer distribution centers that are franchised to service the subject engines.
- (6) The owner must not be charged for diagnostic labor that leads to the Determination that a warranted part is in fact defective, provided that such diagnostic work is performed at a warranty station.
- (7) The manufacturer is liable for damages to other engine components Proximately caused by a failure under warranty of any warranted part.
- (8) Throughout the emissions warranty period defined in Subsection (B2), the manufacturer must maintain a supply of warranted parts sufficient to meet the expected demand for such parts.
- (9) Any replacement part may be used in the performance of any warranty Maintenance or repairs and must be provided without charge to the owner. Such use will not reduce the warranty obligations of the manufacturer.
- (10) Add-on or modified parts that are not exempted by the Air Resources Board may not be used. The use of any non-exempted add-on or modified parts will be grounds for disallowing a warranty claim. The manufacturer will not be liable to warrant failures of warranted parts caused by the use of a non-exempted add-on or modified part.
- (11) The manufacturer issuing the warranty shall provide any documents that describe that manufacturer's warrant procedures or policies within five working days of request by the Air Resources Board.

### (D) Emission Warranty Parts List

- (1) Fuel Metering System
  - (a) Carburetor, internal parts, and pressure regulator.
  - (b) Cold start enrichment system.
- (2) Air Induction System
  - (a) Intake manifold.
  - (b) Air filter.
- (3) Ignition System
  - (a) Spark Plugs.
  - (b) Magneto or electronic ignition system.
  - (c) Spark advance/retard system.
- (4) Exhaust System
  - (a) Exhaust manifold.
- (5) Miscellaneous Items Used in Above Systems
  - (a) Electronic Fuel Cut-off control.
  - (b) Vacuum, temperature, time sensitive valves, and switches.
  - (c) Hoses, belts, connectors, and assemblies.

Amano Pioneer Eclipse Corporation will furnish with each new engine written instructions for the maintenance and use of the engine by the owner.

**Exception:** This warranty does not apply to any machine models that do not have a catalyst muffler.



## SAFETY AWARENESS FORM FOR PROPANE MACHINES

**The following must be completed before an employee may use a propane machine!**

I have read the "Operators Manual" and understand it.

Name:

(Print or Type)

Date:

**Demonstrate to your instructor that you can do the following properly and safely:**

### How to prepare the propane machine for operation:

- A. Install pads.....
- B. Check oil.....
- C. Adjust handle.....
- D. Check fuel cylinder for overfilling.....
- E. Install fuel cylinder.....
- F. Do you have a MSDS for propane?.....

### How to operate a propane machine:

- A. Start and stop the engine.....
- B. Emergency stop.....
- C. Clean air filter.....

### Cautions:

- A. Allow only qualified, trained personnel to operate the machine.
- B. Use only D.O.T. approved fuel cylinders supplied by Amano Pioneer Eclipse.
- C. Always store fuel cylinders outside in a proper enclosure.
- D. Never vent a fuel cylinder inside.
- E. Always wear a CO detector badge.
- F. Never leave the machine running unattended.
- G. Know what to do and whom to call in case of emergency.

**When all items are checked off and this form is signed by an instructor or supervisor, you may operate a propane machine.**

Employee Signature: \_\_\_\_\_

Date: \_\_\_\_\_

Instructor/Supervisor Signature: \_\_\_\_\_

Date: \_\_\_\_\_



# Limited Warranty

## PE440BU Propane Burnisher

### TO QUALIFY FOR THIS WARRANTY

- (1) Machine must be registered at the time of purchase on a form provided by Amano Pioneer Eclipse Corporation. Your Amano Pioneer Eclipse Distributor is responsible for the registration of your machine. Please cooperate with your Distributor in supplying necessary information on the card.
- (2) The machine must have been purchased from Amano Pioneer Eclipse Corporation or an authorized Amano Pioneer Eclipse Distributor.
- (3) This warranty extends to the original purchaser only and is not transferable to subsequent owners.

### TIME PERIODS

- (1) Propane engine warranted by engine manufacturer for (2) years.
- (2) Battery warranted by battery manufacturer for (1) year.
- (3) Valve train warranted by Amano Pioneer Eclipse for (1) year.
- (4) ONE (1) YEAR WARRANTY - For the PE440BU. Warranted to be free from defects in material and workmanship for a period of one (1) year from the date of purchase by the original owners. (See Exclusions)

### EXCLUSIONS (Not Covered by Warranty)

- (1) Parts that fail through normal wear by reason of their characteristics (cords, pads, belts, wheels, pad holder, or other consumable parts).
- (2) This warranty does not extend to parts affected by misuse, neglect, abuse or improper maintenance. All defective parts must be returned to the distributor for credit.

### THE OBLIGATION OF AMANO PIONEER ECLIPSE CORPORATION

- (1) The obligation of Amano Pioneer Eclipse under this warranty is limited to repairing or replacing, at its option, any part which is proven to be defective in material or workmanship under normal use for the applicable period stated above.
- (2) Warranty repairs will be made by your Amano Pioneer Eclipse Distributor without charge for parts and labor. They will be compensated with a warranty labor rate of \$45.00 per hour, for the first year of ownership.
- (3) Parts repaired or replaced under this warranty are warranted only during the balance of the original warranty period. All defective parts replaced under these warranties become the property of Amano Pioneer Eclipse.

### WARRANTY SERVICE

To obtain warranty service, take your machine and proof of purchase to any authorized Amano Pioneer Eclipse Distributor. Amano Pioneer Eclipse will not reimburse expenses for service calls or travel. For the Distributor in your area, call Amano Pioneer Eclipse Customer Service Department at 800-367-3550 or 336-372-8080. If you are dissatisfied with the service that you receive, call or write Amano Pioneer Eclipse Customer Service Department for further assistance.

### INSTRUCTIONS AND CONDITIONS FOR WARRANTY REIMBURSEMENT

- Order replacement part: Orders will be processed and charged, as normal procedure.
- Call Amano Pioneer Eclipse for R/A number.
- You will need the Engine Serial Number, Machine Serial Number, and the Machine Model Number.
- Parts must be returned, accompanied with the R/A number to be eligible for warranty credit.
- All Warranty Parts will be shipped prepaid UPS Ground, any other method will be at the recipients expense.
- Freight on any Warranty Part after 30 days must be paid for by the Purchaser.
- Warranty labor rate is \$45.00 per hour.
- Credit will be issued upon completion of the above steps, at the above rates.

### DISCLAIMER OF CONSEQUENTIAL

AMANO PIONEER ECLIPSE DISCLAIMS ANY RESPONSIBILITY FOR LOSS OF USER TIME OF THE AMANO PIONEER ECLIPSE MACHINE OR ANY OTHER INCIDENTAL OR CONSEQUENTIAL DAMAGE EXCEPT AS STATED IN THE WARRANTY APPLICABLE TO EACH MACHINE. EXCEPT AS STATED IN SUCH WARRANTIES, THE COMPANY DOES NOT OTHERWISE WARRANT ANY MACHINE AND NO WARRANTY, EXPRESS, IMPLIED OR STATUTORY IS MADE BY THE COMPANY.

Copyright 2016 Amano Pioneer Eclipse Corporation



## **Amano Pioneer Eclipse Corporation**

1 Eclipse Rd ● PO Box 909  
Sparta, North Carolina 28675 ● USA  
[www.pioneereclipse.com](http://www.pioneereclipse.com)

+1-336-372-8080  
1-800-367-3550  
Fax +1-336-372-2913

EC Machinery Directive 2006/42/EC,  
EC Restriction of Hazardous Substances Directive (2011/65/EU)  
Harmonized Standards Applied: EN 12100-1, EN12100-2