

# **SABER™ CUTTER**

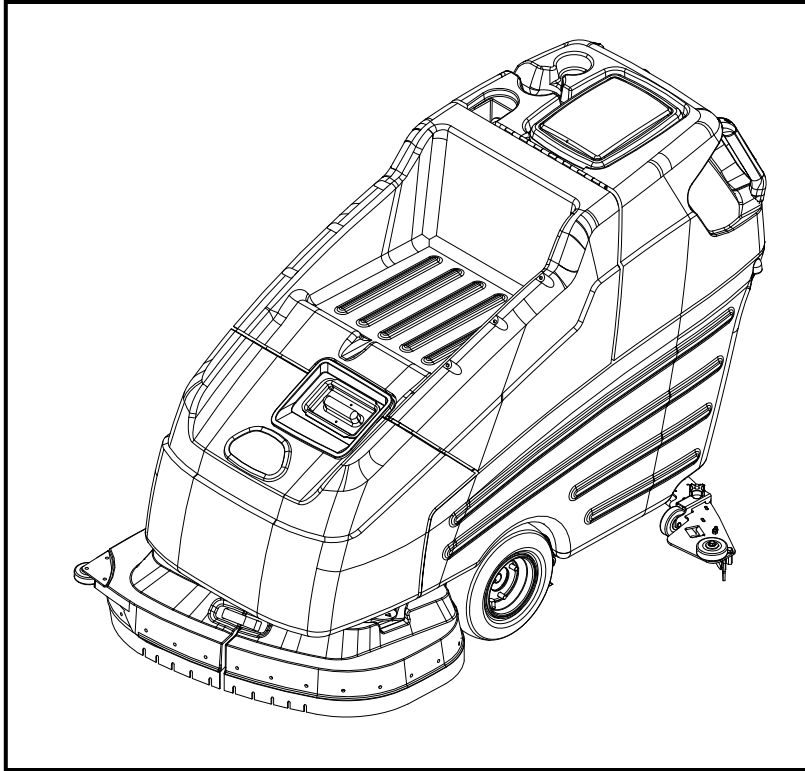

## **WALK BEHIND SCRUBBER**



Operating Instructions

**MODELS:** SC326  
10052220  
SCC326  
10052260  
BSCSC326  
10052890

**QUEST®** ... for Continuous Improvement.  
Windsor's Quality Management System is Certified ISO 9001.



*Read these instructions before using the machine*



86039090 03/27/12

PRV NO. 98965

## MACHINE DATA LOG/OVERVIEW

MODEL	_____
DATE OF PURCHASE	_____
SERIAL NUMBER	_____
SALES REPRESENTATIVE #	_____
DEALER NAME	_____
OPERATIONS GUIDE NUMBER	_____
PUBLISHED	_____

### YOUR DEALER

Name: \_\_\_\_\_

Address: \_\_\_\_\_

Phone Number: \_\_\_\_\_

### OVERVIEW

The Saber Cutter is a battery powered, self-propelled, hard floor scrubber intended for commercial use. The appliance applies a cleaning solution onto a hard floor, scrubs the floor with brushes or pads, and then vacuums the soiled water back into the recovery tank.

## Warranty Registration

Thank you for purchasing a Windsor product. Warranty registration is quick and easy. Your registration will allow us to serve you better over the lifetime of the product.

To register your product go to:

[www.windsorind.com/WarrantyRegistration.aspx](http://www.windsorind.com/WarrantyRegistration.aspx)

For customer assistance:

1-800-444-7654



# TABLE OF CONTENTS

Machine Data Log/Overview.....	2
Table of Contents.....	3

## HOW TO USE THIS MANUAL

How to use this Manual.....	1-1
-----------------------------	-----

## SAFETY

Important Safety Instructions .....	2-1
Hazard Intensity Level. ....	2-2
Safety Label Location. ....	2-3

## OPERATIONS

Technical Specifications. ....	3-1
How the Machine Works. ....	3-3
Components.....	3-4
Controls.....	3-5
Machine Operation.....	3-9
Pre-Run Machine Inspection.....	3-9
Starting Machine. ....	3-9
Emergency Stop Procedures .....	3-9
Filling the Solution Tank.....	3-9
Scrubbing.....	3-9
Emptying & Cleaning Tanks.....	3-11

## MAINTENANCE

Service Schedule.....	4-1
Batteries.....	4-3
Battery Maintenance. ....	4-3
Checking Battery Specific Gravity.....	4-4
Charging the Batteries. ....	4-4
Changing Batteries. ....	4-5
Battery Connections.....	4-5
Squeegee Blades.....	4-6
Adjusting Squeegee.....	4-6
Replace or Rotate Rear Squeegee Blade.. ..	4-6
Replace or Rotate Front Squeegee Blade. ..	4-6
Adjusting Squeegee Pitch.....	4-7
Adjusting Rear Deflection. ....	4-7
Replacing Aqua-Mizer Squeegee Blades .....	4-7
Scrub Brushes. ....	4-8
Types. ....	4-8
Replacing or Installing Scrub Brushes .....	4-8
Float Shut-Off.....	4-8
Solution Strainer .....	4-9
Brush Motor Replacement .....	4-9
Greasing Axle .....	4-9

Traction Motor Brush Replacement.. .....	4-10
Circuit Breaker .....	4-10
Brush Shrouds & Brush Skirts .....	4-10
Vacuum Motor .....	4-11
Machine Troubleshooting .....	4-12

## GROUP PARTS LIST

Control Handle.....	5-1
Cover (Front) & Tank Mount.....	5-3
Cover (Top) & Tank Mount.....	5-5
Decal.....	5-7
Electrical Panel.....	5-9
Lift Handle.....	5-11
Lift Handle Linkage.....	5-13
Recovery Tank.....	5-15
Scrub Brush/Pad Driver 32 in .....	5-17
Scrub Deck Aqua-Mizer.....	5-19
Scrub Deck Motors .....	5-21
Scrub Deck Skirt.....	5-23
Scrub Deck Lift Linkage.....	5-25
Solution.....	5-29
Squeegee .....	5-33
Squeegee Lift Linkage (Lower).....	5-35
Vacuum.....	5-37
Wheels & Frame .....	5-39
Wiring-Battery.....	5-41
Wiring-Control Panel.....	5-43
Wiring-Main Harness .....	5-45
Wiring-Schematic-SC326 .....	5-47
Wiring-Schematic-SCC326.....	5-48
Brake-Option.....	5-49
Emergency Stop-Option .....	5-51
Accessory Pump-Option. ....	5-53
Battery Charger-SCC326.....	5-55
Suggested Spare Parts.....	5-57
EC Declaration of Conformity .....	5-58
Warranty .....	5-59

# HOW TO USE THIS MANUAL

This manual contains the following sections:

- HOW TO USE THIS MANUAL
- SAFETY
- OPERATIONS
- MAINTENANCE
- PARTS LIST

The HOW TO USE THIS MANUAL section will tell you how to find important information for ordering correct repair parts.

Parts may be ordered from authorized Windsor dealers. When placing an order for parts, the machine model and machine serial number are important. Refer to the MACHINE DATA box which is filled out during the installation of your machine. The MACHINE DATA box is located on the inside of the front cover of this manual.

MODEL _____
DATE OF PURCHASE _____
SERIAL NUMBER _____
SALES REPRESENTATIVE # _____
DEALER NAME _____
OPERATIONS GUIDE NUMBER _____
PUBLISHED _____

Copyright 2002 Windsor Industries, Printed in USA

The model and serial number of your machine is on the back panel of the machine.

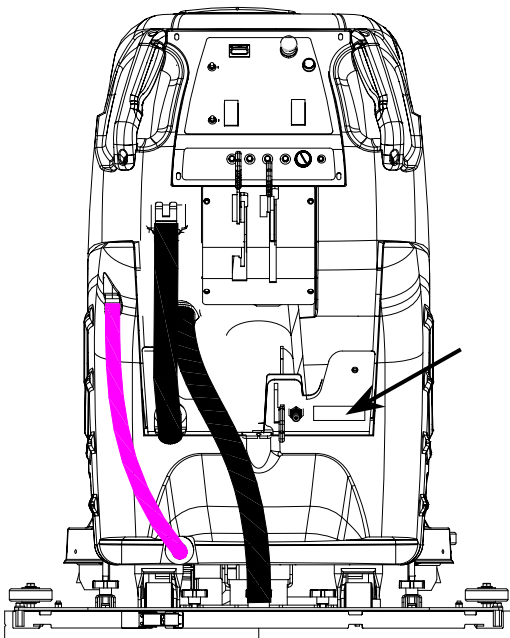

The SAFETY section contains important information regarding hazard or unsafe practices of the machine. Levels of hazards are identified that could result in product or personal injury, or severe injury resulting in death.

The OPERATIONS section is to familiarize the operator with the operation and function of the machine.

The MAINTENANCE section contains preventive maintenance to keep the machine and its components in good working condition. They are listed in this general order:

- Batteries
- Scrub Brushes
- Adjusting Squeegee
- Scrub Deck Skirts
- Squeegee Blade
- Service Schedule

The PARTS LIST section contains assembled parts illustrations and corresponding parts list. The parts lists include a number of columns of information:

- **REF** – column refers to the reference number on the parts illustration.
- **PART NO.** – column lists the part number for the part.
- **PRV NO.** – reference number
- **QTY** – column lists the quantity of the part used in that area of the machine.
- **DESCRIPTION** – column is a brief description of the part.
- **SERIAL NO. FROM** – column indicates the first machine the part number is applicable to. When the machine design has changed, this column will indicate serial number of applicable machine. The main illustration shows the most current design of the machine. The boxed illustrations show older designs. If column has an asterisk (\*), call manufacturer for a serial number.
- **NOTES** – column for information not noted by the other columns.

*NOTE: If a service or option kit is installed on your machine, be sure to keep the KIT INSTRUCTIONS which came with the kit. It contains replacement parts numbers needed for ordering future parts.*

# IMPORTANT SAFETY INSTRUCTIONS

When using an battery powered appliance, basic precaution must always be followed, including the following:

READ ALL INSTRUCTIONS BEFORE USING THIS MACHINE.



## WARNING:

To reduce the risk of fire, electric shock, or injury:

**Use only** indoors. Do not use outdoors or expose to rain.

**Use only** as described in this manual. Use only manufacturer's recommended components and attachments.

If the machine is **not working properly**, has been dropped, damaged, left outdoors, or dropped into water, return it to an authorized service center.

**Do not** operate the machine with any openings blocked. Keep openings free of debris that may reduce airflow.

This machine **is not** suitable for picking up hazardous dust.

**Machine can cause a fire** when operating near flammable vapors or materials. Do not operate this machine near flammable fluids, dust or vapors.

**This machine is suitable for commercial use, for example in hotels, schools, hospitals, factories, shops and offices for more than normal housekeeping purposes.**

Maintenance and repairs **must be done** by qualified personnel.

If foam or liquid comes out of machine, **switch off immediately**.

**Disconnect** battery before cleaning or servicing.

Before the machine is discarded, the batteries **must be removed** and properly disposed of.

Make sure all warning and caution labels **are legible and properly attached** to the machine.

**During operation**, attention shall be paid to other persons, especially children.

**Before use** all covers and doors shall be put in the positions specified in the instructions.

**When leaving unattended**, secure against unintentional movement.

**The machine shall only** be operated by instructed and authorized persons.

**When leaving unattended**, switch off or lock the main power switch to prevent unauthorized use.

**Only chemicals recommended** by the manufacturer shall be used.

**This appliance has been designed** for use with the brushes specified by the manufacturer. The fitting of other brushes may affect its safety.

**Do not** use on surfaces having a gradient exceeding 2% unless the optional parking brake is installed on the machine.

## SAVE THESE INSTRUCTIONS

## **HAZARD INTENSITY LEVEL**

The following symbols are used throughout this guide as indicated in their descriptions:

### **HAZARD INTENSITY LEVEL**

There are three levels of hazard intensity identified by signal words -**WARNING** and **CAUTION** and **FOR SAFETY**. The level of hazard intensity is determined by the following definitions:

#### **⚠ WARNING**

**WARNING** - Hazards or unsafe practices which COULD result in severe personal injury or death.

#### **⚠ CAUTION**

**CAUTION** - Hazards or unsafe practices which could result in minor personal injury or product or property damage.

#### ***FOR SAFETY: To identify actions which must be followed for safe operation of equipment.***

Report machine damage or faulty operation immediately. Do not use the machine if it is not in proper operating condition. Following is information that signals some potentially dangerous conditions to the operator or the equipment. Read this information carefully. Know when these conditions can exist. Locate all safety devices on the machine. Please take the necessary steps to train the machine operating personnel.

#### ***FOR SAFETY:***

**DO NOT OPERATE MACHINE:**

Unless Trained and Authorized.

Unless Operation Guide is Read and understood.

In Flammable or Explosive areas.

In areas with possible falling objects.

#### ***WHEN SERVICING MACHINE:***

**Avoid moving parts. Do not wear loose clothing; jackets, shirts, or sleeves when working on the machine. Use Windsor approved replacement parts.**

#### **⚠ WARNING**

**Batteries emit hydrogen gas. Explosion or fire can result. Keep sparks and open flame away. Keep top cover in raised position when charging. Keep sparks and flames away from the batteries. Do not smoke around batteries.**

#### **⚠ WARNING**

**Disconnect batteries before working on machine. Only qualified personnel should work inside machine. Always wear eye protection and protective clothing when working on or near batteries. Avoid skin contact with the acid contained in the batteries.**

#### **⚠ WARNING**

**Never allow metal to lie across battery tops.**

# SAFETY LABEL LOCATION

NOTE: These drawings indicate the location of safety labels on the machine. If at any time the labels become illegible, promptly replace them.

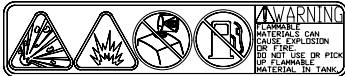

SAFETY DECAL  
86252530  
PRV NO. 81494

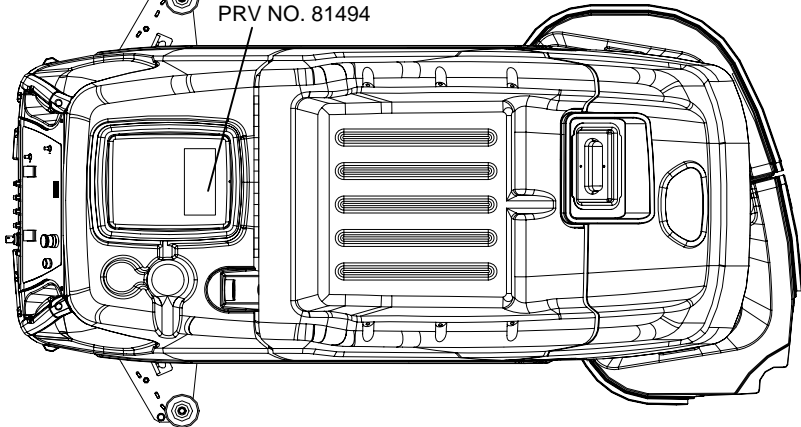

BATTERY CAUTION  
86252520  
PRV NO. 80885

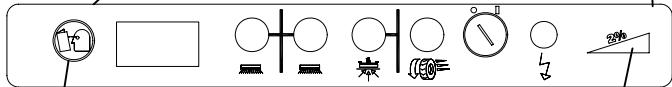
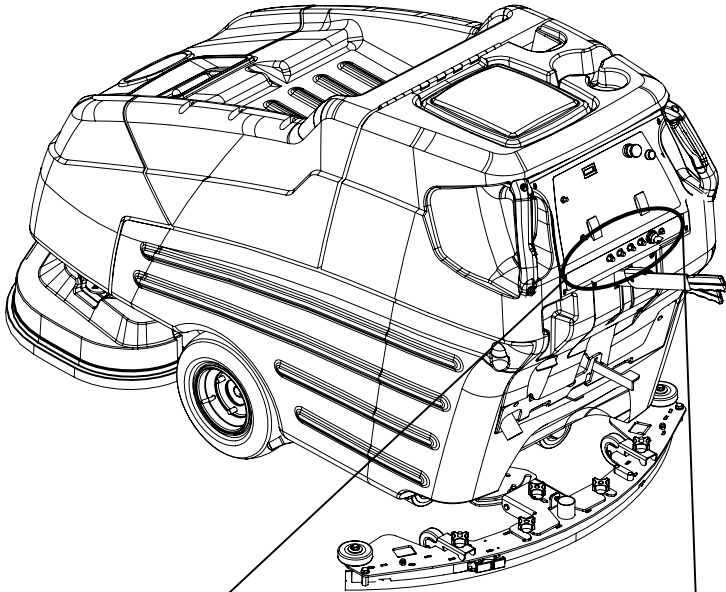
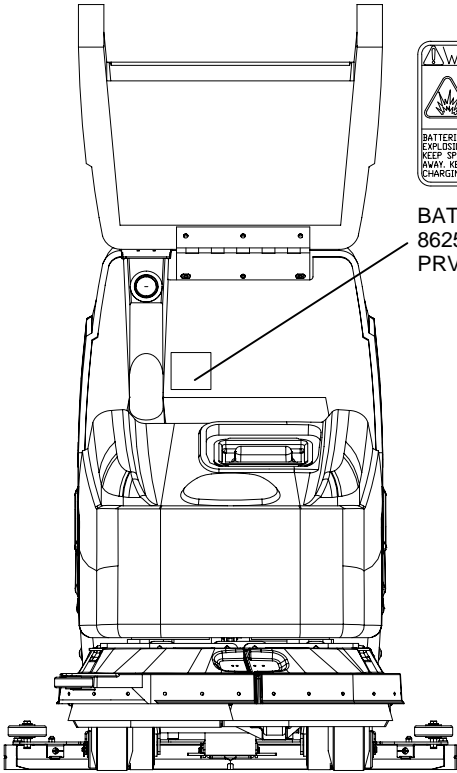

SEE MANUAL

CIRCUIT BREAKER DECAL  
86243610  
PRV NO. 500579

2% GRADE WARNING

## TECHNICAL SPECIFICATIONS

ITEM	DIMENSION/CAPACITY
Nominal power	2160 W
Rated Voltage	36 Volt DC
Rated Amperage	60 amps
Batteries	6 x 6 volt 250-305-335 AH @ 20 Hr rate
Scrub Brush Motors	2 x .75 hp (.56 kW )
Vacuum Motor	3 Stage .75 hp (.56 kW )
Propelling Motor	.75 hp (.56 kW )
Mass (GVW)	1265 lb (574 kg) w/335 AH batteries
Weight empty without batteries	433 lb (196 kg)
Solution Control	Gravity feed, fully variable with automatic shut-off in neutral
Solution tank capacity	32 gal (118 L)
Recovery tank capacity	35 gal (123 L)
Scrub brush diameter 32 in. (81 cm) scrub head	16 in (41 cm)
Scrub brush pressure	Mechanical, 80 lbs floating 130 lbs restricted (356n-578n)
Scrub brush speed	200 rpm
Tires	2 x 12 in (30.5 cm) Non-Mark Foam Fill
Casters	2 x 4 in (10.2 cm) polyurethane, Non-Mark
Foundation Pressure	64 lbs/in <sup>2</sup> (441 kPa)
Maximum Speed	3.2 miles/hour (5.2 kW/hour)
Frame Construction	Powder coated steel
Brakes (optional)	Tire lock parking
Minimum aisle u-turn width with 32 in. (81 cm) scrub head	69 inches (175 cm)
Maximum rated climb and descent angle with empty tanks and without optional parking brake	2%
Maximum rated climb and descent angle with full tanks and without optional parking brake	2%

## TECHNICAL SPECIFICATIONS

ITEM	MEASURE
Height	46 in (117 cm)
Length with 32 in. (81 cm) scrub head	71 in (180)
Width without squeegee and scrub head	28 in (71 cm)
Width of squeegee for 32 in. (81 cm) scrub head	39 in (99 cm)
Width of scrub path for 32 in. (81 cm) scrub head	32 in (81 cm)

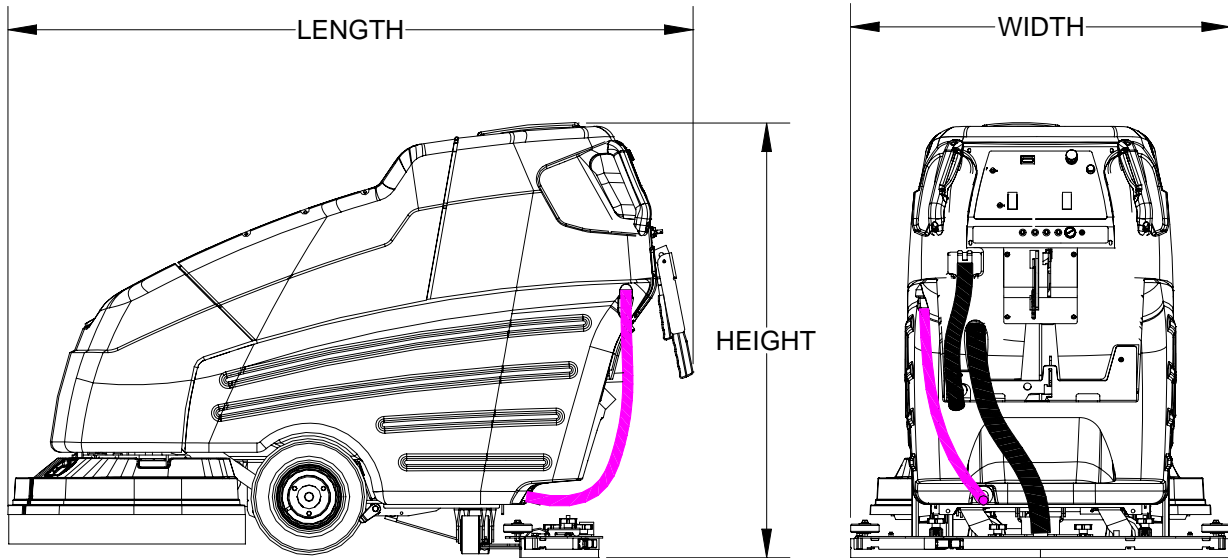

### SPECIAL NOTES:

The sound pressure level at the operator's ear was measured to be 75 dBA. This was a nearfield, broad-band measurement taken in a typical industrial environment on a tile floor. This appliance contains no possible source of impact noise. The instantaneous sound pressure level is below 63 Pa.

The weighted root mean square acceleration at the operator's arms was measured to be below  $2.5\text{m/s}^2$ . This was a tri-axial, third-octave-band measurement made during normal operation on a composite tile floor. The measurement and related calculations were made in accordance with ANSI S3.34-1986.

## **HOW THE MACHINE WORKS**

The Saber Cutter is a battery powered, self-propelled, hard floor scrubber intended for commercial use. The appliance applies a cleaning solution onto a hard floor, scrubs the floor with brushes, and then vacuums the soiled water back into the recovery tank.

The machine's primary systems are the solution system, scrub system, recovery system, and directional control system.

The function of the solution system is to store cleaning solution and deliver it to the scrub system. The solution system consists of the solution tank, strainer, valve and controls. The solution tank stores cleaning solution (water and detergent) until it is delivered to the scrub system. The strainer protects the valve from debris. The valve is a solenoid type valve, which controls the delivery of cleaning solution to the scrub system. The valve automatically prevents solution flow unless the scrub brushes are turned on and the machine is being propelled. The solution control knob controls the amount of cleaning solution delivered to the scrub system by controlling the amount of time the valve is open.

The function of the scrub system is to scrub the floor. The scrub system consists of two rotary type disk scrub brushes, motors, scrub deck skirt, lift mechanism and controls. The brushes scrub the floor and the motors drive the brushes. The brush drive hubs allow the scrub brushes to follow irregularities and changes in the floor without losing contact with floor. The scrub deck skirt controls the cleaning solution on the floor so that the squeegee can pick it up. The brush lever is used to raise and lower the deck.

The function of the recovery system is to vacuum the soiled water back into the recovery tank. The recovery system consists of the squeegee, vacuum motor, float ball filter, recovery tank and controls. The squeegee wipes the dirty solution off the floor as the machine moves forward. The vacuum motor provides suction to draw the dirty solution off the floor and into the recovery tank. The recovery tank stores the dirty solution. The float ball filter protects the vacuum fan from debris and shuts off air going to the recovery tank when tank is full. When flow of air is shut off the vacuum motor will continue to run. At this time the recovery tank must be drained.

The function of the directional control system is to control the direction and speed of the machine. The directional control system consists of the propel control buttons, reverse button, speed control knob/potentiometer, controller and transaxle. The propel controls actuate switches which cause the machine to move forward. For reverse motion depress the reverse button while depressing one of the propel controls. The speed control knob actuates a potentiometer, which signals speed. The controller interprets the forward/reverse signals from the switches and the speed signal from the potentiometer to command the transaxle to propel the machine in the direction, and at the speed, desired.

## COMPONENTS

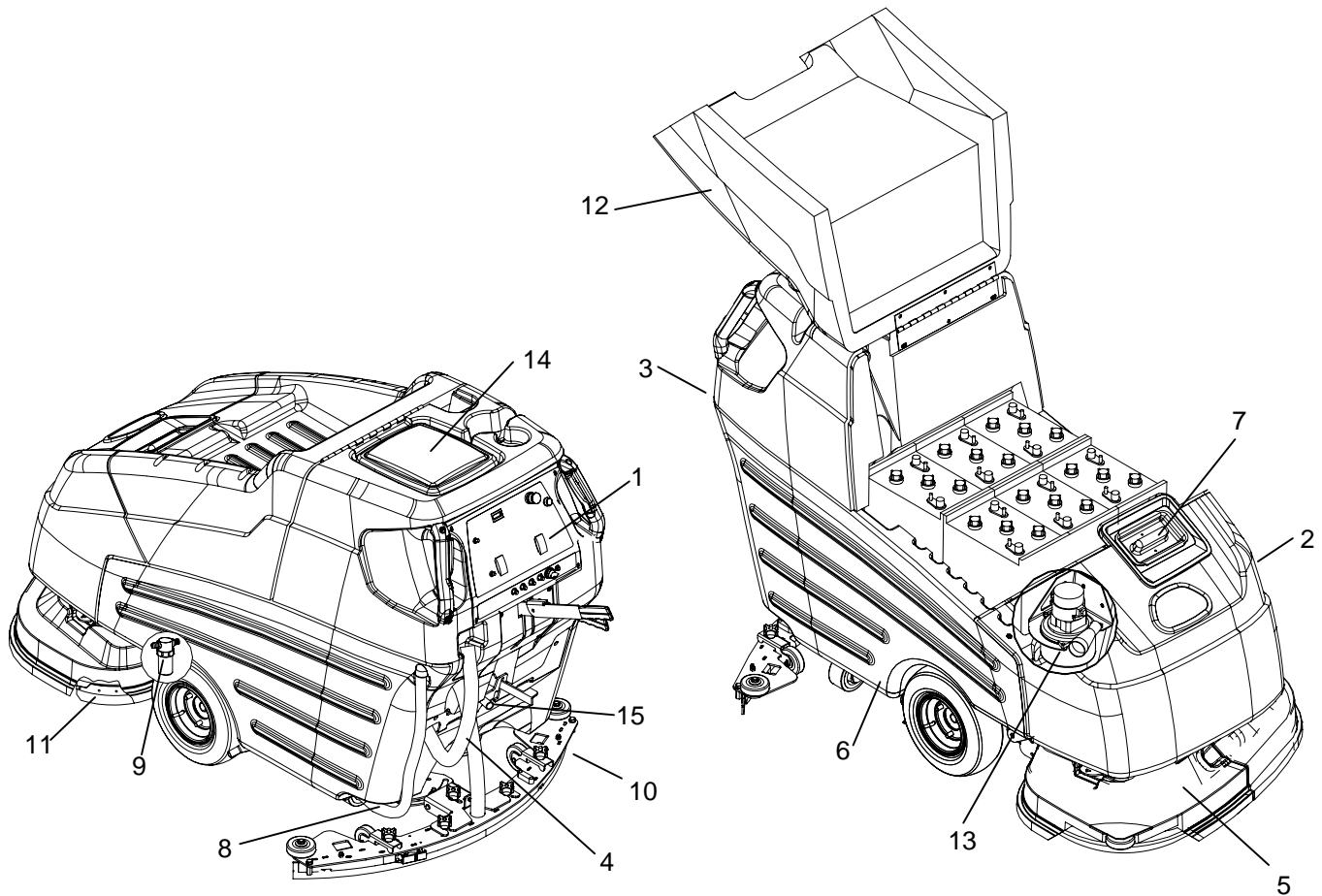

1. **Control Panel**
2. **Front Cover**
3. **Recovery Tank**
4. **Recovery Tank Drain Hose**
5. **Scrub Head Shrouds**
6. **Solution Tank**
7. **Solution Tank Cover**
8. **Solution Tank Drain Hose**
9. **Solution Strainer**
10. **Squeegee**
11. **Aqua-Mizer**
12. **Top Cover**
13. **Vacuum Motor**
14. **Recovery Tank Dome**
15. **Accessory Pump Port (Optional)**

# CONTROLS

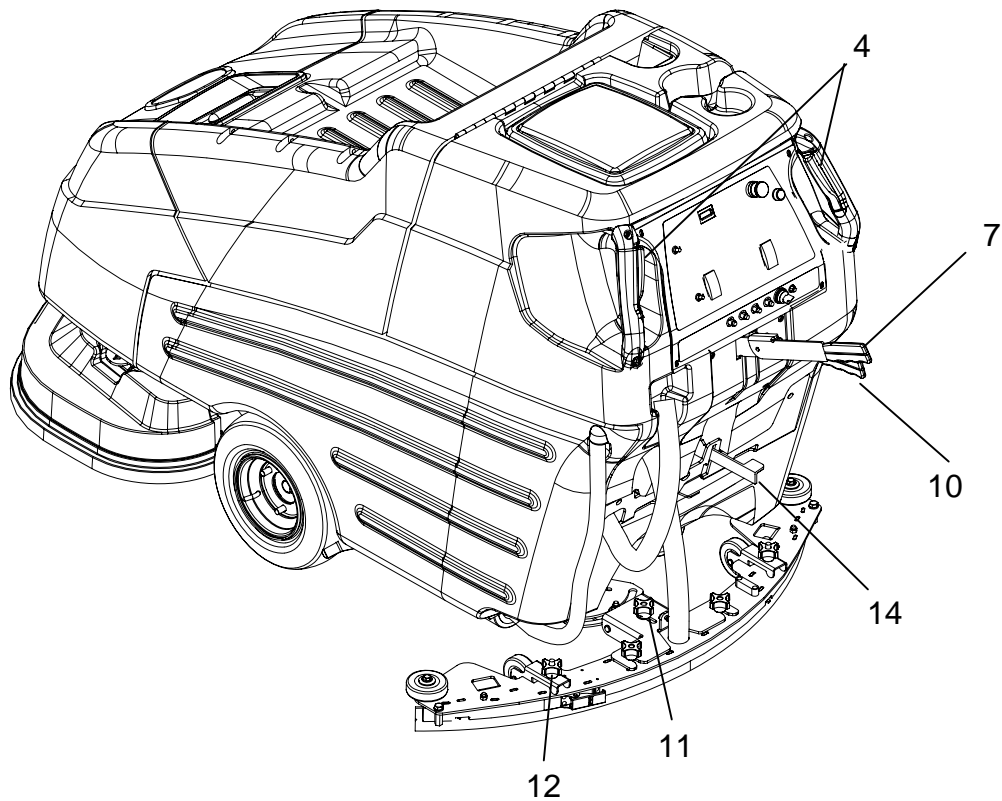
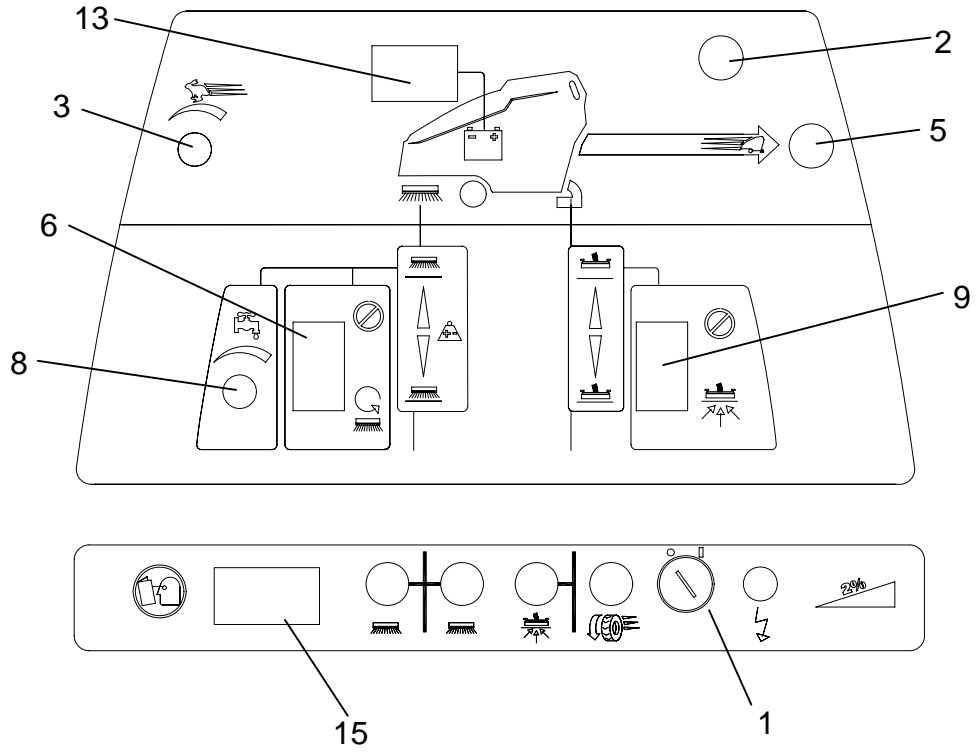

1. **Key Switch**
2. **Emergency Shut-Off Switch**
3. **Speed Control Knob**
4. **Propel Control Lever**
5. **Reverse Button**
6. **Brush Switch**
7. **Brush Lift Lever**
8. **Solution Control Knobs**
9. **Vacuum Switch**
10. **Squeegee Lift Lever**
11. **Squeegee Pitch Adjustment Knob**
12. **Squeegee Deflection Adjustment Knobs**
13. **Battery Charge Level Indicator**
14. **Parking Brake (Optional)**
15. **Hour Meter (Optional)**

---

## 1. KEY SWITCH

Controls the power for machine functions.

To turn machine on, rotate key clockwise.

To turn machine off, rotate key counterclockwise.

***FOR SAFETY: Always remove the key when machine is unattended or during service to prevent unauthorized movement.***

## 2. EMERGENCY SHUT-OFF SWITCH (OPTIONAL)

Shuts off machine.

To shut off machine, push the switch.

To restart machine, rotate the switch clockwise.

## 3. SPEED CONTROL KNOB

Controls the speed of the machine.

To increase speed, rotate knob clockwise.

To decrease speed, rotate knob counterclockwise.

## 4. PROPEL CONTROL LEVERS

Controls the machine direction, and scrub brushes and solution flow.

To propel machine forward, squeeze either propel lever.

The scrub brushes will not rotate and the solution will not flow to scrub deck with the propel levers in neutral.

## 5. REVERSE BUTTON

Controls the reverse function.

To propel machine backward, push the reverse button while squeezing either propel lever.

## 6. BRUSH SWITCH

Controls the scrub brush motors.

To turn scrub brushes on, press the bottom of the switch. The brushes will not rotate with the propel control levers in neutral.

To turn scrub brushes off, press the top of the switch.

# CONTROLS

## 7. BRUSH PRESSURE LEVER

Adjusts the amount of brush pressure to the floor by raising or lowering the scrub deck.

To apply brush pressure, lower brush pressure lever to floating position.

To apply additional pressure, place lever in restricted position. Lock the lever into the lower notch. Push the lever forward to move in a downward motion. Pull back on lever and release for floating position.

To decrease brush pressure, raise lever to up position.

## 8. SOLUTION CONTROL KNOB

Controls solution flow to scrub deck.

To increase flow, rotate knob clockwise.

To decrease flow, rotate knob counterclockwise.

If the brush motors are turned off or the propel control levers are in neutral, the flow is automatically interrupted until the motors are turned on again. This feature prevents unintentional draining of the solution tank and allows the operator to adjust the solution flow to the scrub deck without resetting each time the scrubbing operation is interrupted.

## 9. VACUUM SWITCH

Controls the vacuum motor.

To start vacuum motor, press the bottom of the switch.

To stop vacuum motor, press the top of the switch.

## 10. SQUEEGEE LIFT LEVER

Raises and lowers the squeegee.

To lower the squeegee, lift the lever from its raised position.

To raise the squeegee, lift the lever from its lowered position.

## 11. SQUEEGEE PITCH ADJUSTMENT KNOB

Adjusts the deflection at the ends of the squeegee.

To increase squeegee blade deflection at the ends, turn knob counterclockwise.

To decrease squeegee blade deflection at the ends, turn knob clockwise.

## 12. SQUEEGEE DEFLECTION ADJUSTMENT KNOBS

Adjusts the deflection along the entire length of the squeegee.

To increase squeegee blade deflection along the entire length, turn the two knobs at the squeegee ends counter-clockwise.

To decrease squeegee blade deflection along the entire length, turn the two knobs at the squeegee ends clockwise.

## **13. BATTERY CHARGE LEVEL INDICATOR**

Indicates the charge level of the batteries.

The meter display is divided into 10 vertical bars. Bar illuminated on the far right indicate full charge. Bars flashing near the left side indicate the batteries should be recharged. Further operation of the machine could damage the machine or the batteries.

When the machine is left overnight with less than a full charge, the display may initially indicate a full charge. It will also indicate a full charge if the batteries are disconnected, then reconnected. After a few minutes of operation the meter will give the correct charge level.

## **14. PARKING BRAKE (OPTIONAL)**

Locks front wheels to prevent unintentional movement.

To set parking brake, push down to lock notch.

To release parking brake, push down and over out of the lock down notch.

## **15. HOUR METER (OPTIONAL)**

Records the number of hours the machine has been in operation. This information is useful in determining when to service the machine.

## **MACHINE OPERATION**

### **PRE-RUN MACHINE INSPECTION**

Do a pre-run inspection to find possible problems that could cause poor performance or lost time from breakdown. Follow the same procedure each time to avoid missing steps.

*NOTE: See maintenance section for pre-run machine inspection checklist items.*

### **STARTING MACHINE**

*NOTE: Perform pre-run machine check before operating machine.*

**FOR SAFETY: Before starting machine, make sure that all safety devices are in place and operating properly.**

1. Turn the machine power on.
2. Release the parking brake, if your machine is equipped with this option.
3. Engage the direction propel levers for the desired direction.

### **EMERGENCY STOP PROCEDURES**

1. Release the propel levers.
2. Turn machine power off with key switch.
3. If an electrical problem is suspected push in emergency stop button, if machine is equipped with this option.
4. Apply brakes, if your machine is equipped with this option.

### **FILLING SOLUTION TANK**

**FOR SAFETY: Before leaving or servicing machine; stop on level surface, turn off machine and remove key.**

1. Turn the machine power off.
2. Set the parking brake if your machine is equipped with this option.
3. Remove solution tank cover.
4. Fill the solution tank with clean water, leaving enough room for the required amount of cleaning solution. The solution tank capacity filled to 2" (5 cm) from bottom of fill inlet is 23 gallons (87 liters). The water must not be hotter than 140° F (60°C) to prevent damage to the tank.
5. Measure the chemical into the solution tank. Liquid chemicals should be added to the solution tank after filling with water. Dry chemicals should be thoroughly mixed before being added into solution tank. Commercially available, high alkaline floor cleaners, are suitable for use in the solution system.

*NOTE: Read the chemical manufacturers recommended proportion instructions.*

6. Replace solution tank cover.

### **WARNING**

**Flammable materials can cause an explosion or fire. Do not use flammable materials in the tanks.**

## NORMAL SCRUBBING

Plan the scrubbing pattern in advance. The longest track is around the perimeter of the area to be cleaned. For efficient operation, the runs should be the longest possible without turning, stopping, or raising and lowering scrub deck/squeegee.

*NOTE: In order to achieve the best possible results, the area which is to be cleaned should be*

## INEFFICIENT SCRUBBING PATH

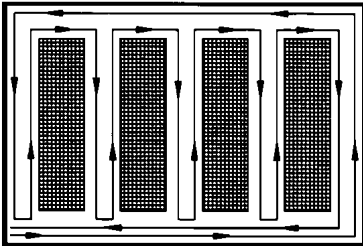

## RECOMMENDED SCRUBBING PATH

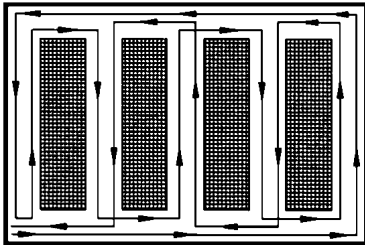

*swept before scrubbing. Large debris, strings & wire must be removed to prevent being caught in brushes or squeegee.*

## TO BEGIN SCRUBBING

### **⚠ WARNING**

**When operating the machine around people, pay close attention for unexpected movement. Use extra caution around children.**

### **⚠ CAUTION**

**Flammable liquids and/or reactive metals can cause explosions or fire! Do not pick up.**

1. Turn the machine power on.
2. Lower the squeegee.
3. Turn the vacuum on.
4. Lower the scrub brushes to the floor.
5. Turn the scrub brushes on (brushes will start when machine is propelled).
6. Drive machine forward to begin scrubbing.  
*NOTE: Shut machine off immediately if water or foam is expelled from the machine.*
7. Adjust the speed of the machine, solution flow and scrub brush pressure as necessary.  
*NOTE: Once solution flow rate is set it is not necessary to shut off solution when stopping scrubbing. Solution flow is automatically shut off when brush motors stop. When brush motors are activated, flow automatically resumes.*

## TO STOP SCRUBBING

1. Release the propel levers.
2. Turn the scrub brushes off.
3. Raise the scrub brushes.
4. Raise the squeegee.
5. Turn the vacuum off.
6. Turn the machine power off.

# MACHINE OPERATION

## DOUBLE SCRUB

For floors which are heavily soiled or have thick accumulations of floor finish may not clean sufficiently with one pass. In these cases it will be necessary to double scrub.

To double scrub, make the first pass over the surface being cleaned with the squeegee up, vacuum off, the solution on, Aqua-Mizer removed and brushes down. This allows the solution to stay in contact with the soil while loosening the surface accumulation with the brushes. Allow time for the first application to stay in contact with the floor.

Length of time between the first and second pass depends on amount of accumulation and the type of chemical being used. A second scrubbing with the squeegee down and again the solution and brushes on will further loosen soil. The additional application of solution will further assist the difficult cleaning job.

**FOR SAFETY: When using machine, go slow on inclines and slippery services.**

## EMPTYING AND CLEANING TANKS

1. Park the machine next to a floor drain. Drain hose is on left rear corner of the machine.
2. Turn the machine power off and set parking brake, if your machine is equipped with this option.

### SOLUTION TANK

1. Loosen small drain hose from the retainer, then lower hose in direction of the drain.
2. Remove the solution tank cover.
3. Flush the solution tank out with clean water and run several gallons of clean water through systems. Do not use water hotter than 140°F (60°C) to clean tank. Damage may occur.

*NOTE: Never allow solution to remain in tank. Damage to tank, seals and valves could occur.*

4. Secure drain hose into the retainer.

### RECOVERY TANK

1. Unhook the large drain hose from the retainer. Unscrew the T-handle on plug enough to loosen plug, then lower hose in direction of the drain. Do not stand in front of end of hose. Recovered solution will come out with force. Slowly remove plug from drain hose.
2. Remove the recovery tank dome. Flush the recovery tank out with clean water. Do not use water hotter than 140°F (60°C) to clean tank. Damage may occur.
3. Clean off the float shut-off system and inspect for free movement of float. The float shut-off system is located in the rear of the recovery tank.
4. Replace the drain plug and secure drain hose in bracket.
5. If machine is to be stored, leave the recovery tank dome off.

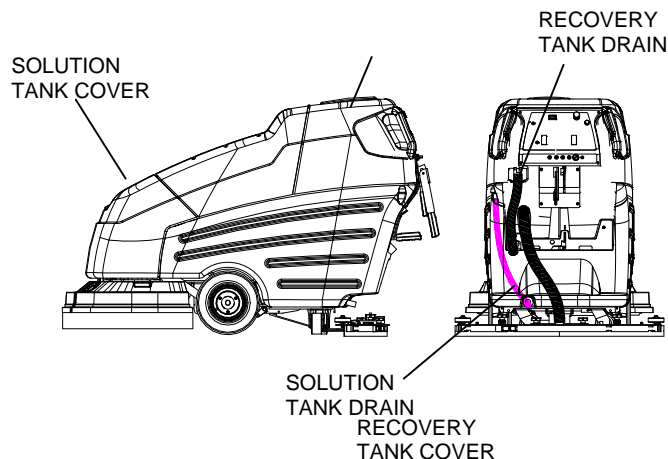

**SERVICE SCHEDULE**

MAINTENANCE	DAILY	WEEKLY	MONTHLY	50 HRS	100 HRS	200 HRS
Check batteries after charging; add water if necessary	*					
Check pad wear to prevent buildup of chemicals	*					
Check linkages and connectors for wear and damage	*					
Check hoses for wear, blockages, or damage	*					
Clean squeegee; check for adjustment; inspect for wear	*					
Check handles, switches, knobs, domes, and gaskets for damage	*					
Clean out recovery tank	*					
Clean out solution tank; remove and clean screen	*					
Clean outside of all tanks; check for damage	*					
Run vac motor for at least one minute to allow motor to dry	*					
Store with dome off tank to allow the tank to dry	*					
Check scrub deck splash skirt		*				
Check batteries for corrosion, cracks and evidence of overheating			*			
Check all bearings for noise			*			
Check all gaskets for wear and leakage			*			
Check vac motor carbon brushes			*			
Check brushes for wear; ensure bristles are not damaged			*			
Check linkages for wear and damage			*			
Grease wheels and casters			*			
Grease axle			*			
Check squeegee blades for wear and frame for damage			*			
Check overall performance of machine			*			
Lubricate squeegee caster				*		
Clean batteries and terminals					*	
Thoroughly clean the machine					*	
Check carbon brushes in all vacuum, brush drive, and propel motors						*
Blow out dust in motors						*
Inspect motor commutators						*
Clean chains, cables and pulleys						*
Clean pivot points on squeegee and scrub deck linkages						*

# MAINTENANCE

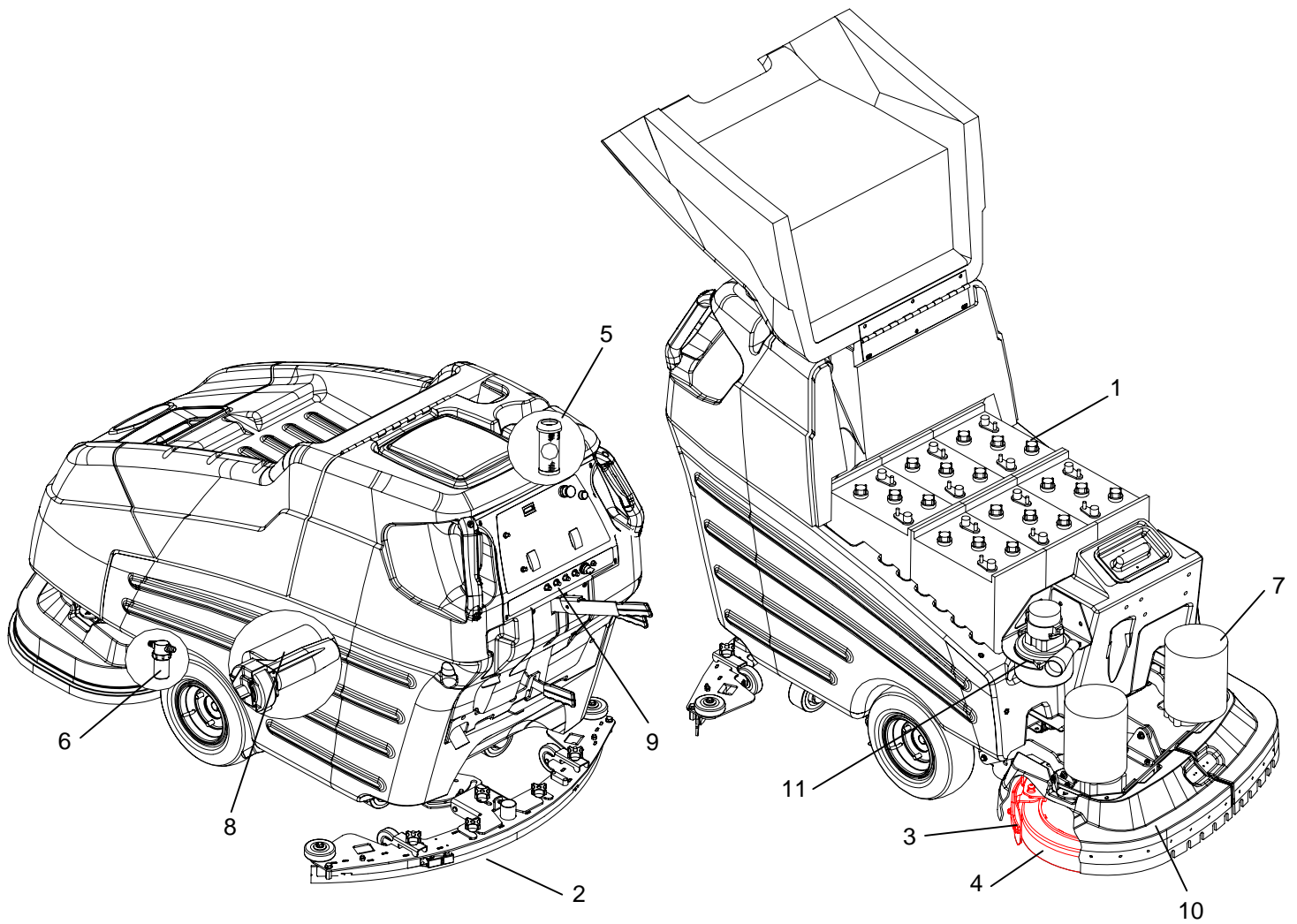

1. **Batteries**
2. **Squeegee**
3. **Aqua Mizer**
4. **Scrub Brushes**
5. **Recovery Tank Float Shut-Off**
6. **Solution Strainer**
7. **Brush Motor**
8. **Traction Motor**
9. **Circuit Breakers**
10. **Brush Shroud & Brush Skirts**
11. **Vacuum Motor**

## 1. BATTERIES

The batteries provide the power to operate the machine. The batteries require regular maintenance to keep them operating at peak efficiency.

The machine batteries will hold their charge for long periods of time, but they can only be charged a certain number of times. To get the greatest life from the batteries, charge them when their charge level reaches 25% of a full charge. Use a hydrometer to check the charge level.

Do not allow the batteries to remain in a discharged condition for any length of time. Never expose a discharged battery to temperatures below freezing. Discharged batteries will freeze causing cracked cases. Do not operate the machine if the batteries are in poor condition or if they have a charge level below 25% (specific gravity below 1.155).

Keep all metallic objects off the top of the batteries, as they may cause a short circuit. Replace worn or damaged cables and terminals.

Check the electrolyte level in each battery cell before and after charging the batteries. Never add acid to the batteries, use distilled water. Do not allow water level to fall below the battery plates. Portions of plates exposed to air will be destroyed. Do not overfill. Keep plugs firmly in place at all times.

### CAUTION

When servicing machine, avoid contact with battery acid.

### WARNING

Batteries emit hydrogen gas. Explosion or fire can result. Keep sparks and open flame away. Keep covers open when charging.

### WARNING

Wear eye protection and protective clothing when working with batteries.

### WARNING

Charge batteries in a well ventilated area.

## BATTERY MAINTENANCE

1. When cleaning the batteries, use a solution of baking soda and water. Do not allow the cleaning fluid to enter the battery cells, electrolyte will be neutralized.
2. Maintain the proper electrolyte level in each battery cell. If a cell should accidentally overflow, clean immediately.
3. Wipe off the top of the batteries at least once a week.
4. Test battery condition with a hydrometer at least once a week.
5. Ensure that all connections are tight and all corrosion removed.
6. Every 4 to 6 months, remove that batteries from the machine and clean the battery cases and battery compartment.

## MAINTENANCE

### CHECKING BATTERY SPECIFIC GRAVITY

Use a hydrometer to check the battery specific gravity.

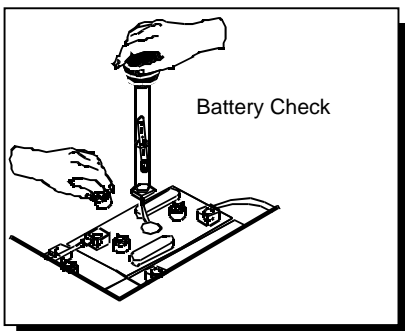

### CHECKING GRAVITY

#### A. Hydrometer

#### B. Battery

*NOTE: Do not take readings immediately after adding distilled water, if the water and acid are not thoroughly mixed, the reading may not be accurate.*

Check the hydrometer readings against this chart.

SPECIFIC GRAVITY @ 80° F (27°C)	BATTERY CONDITION
1.265	100% CHARGED
1.225	75% CHARGED
1.190	50% CHARGED
1.155	25% CHARGED
1.120	DISCHARGED

*NOTE: If the readings are taken when the battery electrolyte is any temperature other than 80° F (27°C), the reading must be temperature corrected.*

To find the corrected specific gravity reading when the temperature of the battery electrolyte is other than 80°F (27°): Add (+) to the specific gravity reading 0.004 (4 points), for each 10°F (6°C) above 80° (27°C).

Subtract (-) from the specific reading 0.004 (4 points), for each 10°F (6°C) below 80°F (27°C).

### TO CHARGE THE BATTERIES

#### **⚠ WARNING**

When servicing machine, avoid contact with battery acid.

#### **⚠ CAUTION**

Batteries emit hydrogen gas. Explosion or fire can result. Keep sparks and open flame away. Keep covers open when charging.

#### **⚠ WARNING**

Wear eye protection and protective clothing when working with batteries.

#### **⚠ WARNING**

Charge batteries in a well ventilated area. Leave the battery cover open.

Use a 36 volt, 18 amp maximum output or 25 amp (depending on the size of the batteries), DC charger which will automatically shut off when the batteries are fully charged.

1. Stop the machine in a clean, well ventilated area next to the charger. w
2. Turn "OFF" machine.

**FOR SAFETY: Before leaving or servicing machine; stop on level surface, turn off machine and remove key.**

3. Raise the battery cover.

#### **⚠ WARNING**

Batteries emit hydrogen gas. Explosion or fire can result. Keep sparks and open flame away. Keep covers open when charging.

4. Check the electrolyte level in each battery cell. Before charging, add just enough distilled water to cover the plates. After charging is complete, add just enough distilled water to bring up the level to the indicator ring. If the water level is too high before charging, normal expansion rate of the electrolyte may cause an overflow. Resulting in a loss of battery acid balance and damage the machine.

5. Replace the battery caps, and leave them in place while charging.
6. Unplug the battery connector from the machine.

**FOR SAFETY: When charging, connect the charger to the batteries before connecting the charger to the AC wall outlet. Never connect the charger to the AC wall outlet first. Hazardous sparks may result.**

7. Plug the charger connector into the battery connector. Connect the charger AC plug to a wall outlet. The charger gauge should indicate that the batteries are charging.
8. When the batteries are fully charged, disconnect the charger from the AC wall outlet, then disconnect the charger from the batteries.
9. Connect the batteries to the machine connector.
10. Check the electrolyte level. It should be up to the indicator ring. If necessary, add distilled water.
11. Lower the battery cover.

### Machines equipped with Onboard Charger:

1. Connect charger's AC power cord to AC mains. The charger's YELLOW "AC" LED will light.

**Note: When charger is energized, all machine function will shut down.**

2. Current level being delivered to the batteries will be displayed on the charger's bar graph.
3. When battery charge level has reached 80% the YELLOW "80%" LED will light.
4. Batteries will then receive a low current "finish-charge" indicated by the flashing GREEN "100%" LED.
5. Charging cycle is complete when "100%" LED is continuously GREEN.
6. Disconnect charger's AC power cord.
7. Raise battery cover and check the battery electrolyte level. It should be up to the indicator ring. If necessary, add distilled water.
8. Lower the battery cover.

**Note: For additional information about battery charger function, please see the charger Product Manual.**

### CHANGING BATTERIES

Stop the machine in a clean area next to the charger. Turn off machine.

**FOR SAFETY: Before leaving or servicing the machine; stop on level surface, turn off machine and remove key.**

1. Raise the battery cover.
2. Disconnect battery pack from machine.
3. Use the proper size open end wrench to disconnect main ground wire first and secure cable terminal away from batteries.
4. Disconnect main positive lead and secure cable terminals away from batteries.
5. Loosen both terminals on each jumper cable and remove one at a time.
6. Prepare a suitable site to place the batteries.
7. Attach suitable battery lifting device and lift batteries from the machine.

### **! WARNING**

**Batteries are a potential environmental hazard. Consult your battery supplier for safe disposal methods.**

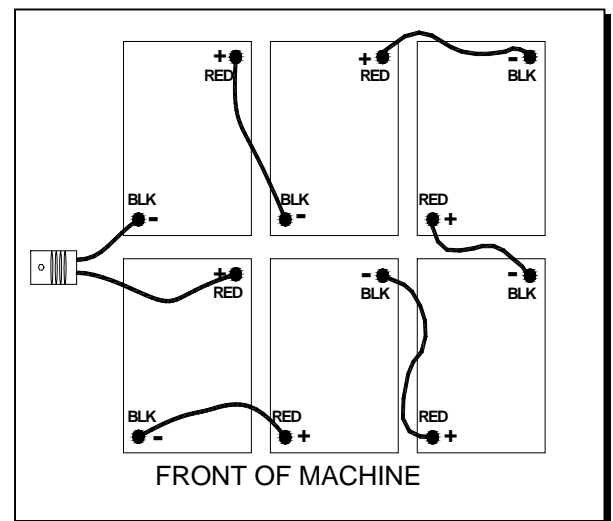

# MAINTENANCE

## 2. SQUEEGEE BLADES

The front squeegee blade allows solution to pass through channels in the blade into the squeegee assembly while maintaining vacuum to provide lift. The front blade has four wear surfaces and can be rotated for extended life. The front blade should not require regular replacement under normal use.

The rear blade wipes the floor to a near dry condition. It is important the rear blade be in good condition to properly do its job. As with the front, each squeegee blade assembly has four wear surfaces for extended service.

Check both the front and rear squeegee blades for damage, wear, and adjustment each day in the pre-run check. Change the front blade if it is torn or has an uneven edge. Change the rear blade if it is less than 1/2 the original thickness.

### ADJUSTING SQUEEGEE

Adjusting the squeegee is a two-part process. First, the squeegee assembly must have correct pitch in order for the squeegee blade to have the same deflection at each tip as well as the center. The knob on the squeegee linkage controls the pitch adjustment. The second adjustment is the deflection. Knobs on each end of the squeegee control this.

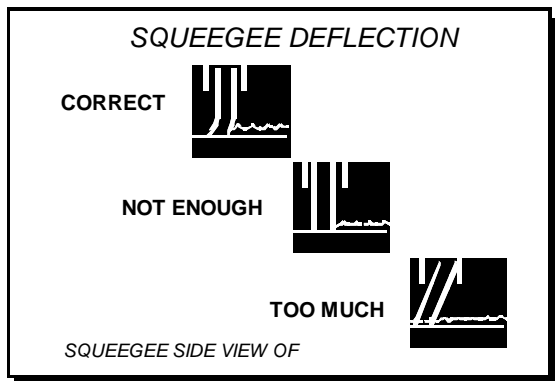

### TO REMOVE SQUEEGEE ASSEMBLY

1. With the squeegee in the up position, turn key switch "OFF".
2. Disconnect vacuum hose from squeegee and loosen both knobs.
3. Pull squeegee assembly rearward from the lifting carrier.
4. Inspect or repair as necessary and reinstall.

### TO REPLACE OR ROTATE REAR SQUEEGEE BLADES

1. With the squeegee in the up position, turn key switch "OFF".  
**FOR SAFETY: Before leaving or servicing machine; stop on level surface, turn off machine and remove key.**
2. Remove the squeegee assembly from the machine. Unlatch and remove blade retainer strap and remove squeegee blade.
3. Rotate the squeegee to new edge position or replace as required. Each blade has four new edge positions.
4. Install blade on locating pins of squeegee assembly.
5. Install squeegee retainer strap.
6. Fasten and lock latch, adjust latch only tight enough to take up slack in retaining strap.

### TO REPLACE OR ROTATE FRONT SQUEEGEE BLADE

1. With the squeegee in the up position, turn key switch "OFF".
2. Remove the squeegee from the machine. Loosen three thumbscrews and remove the retainer strap and squeegee blade.
3. Rotate the squeegee to new edge position or replace as required. Each blade has four new edge positions. When installing the front blade, tighten the center thumbscrew first. Insure that the retainer strap is pressed against the blade before tightening the outer screws.

## TO ADJUST SQUEEGEE PITCH

1. Choose a smooth, level surface. Turn "ON" the key switch. Lower the squeegee and drive forward at least 2 feet (60cm.).
2. With the squeegee down, stop the machine. Do not allow machine to roll back.

**FOR SAFETY: Before leaving or servicing the machine; stop on level surface, turn off machine and remove key.**

3. Determine the differences, if any, in deflection of the squeegee blade between each end and the middle. Proper adjustment is obtained when deflection is equal all the way across the squeegee blade. The bubble level should also indicate when the squeegee is adjusted properly. When the air bubble is in the center of the vial, the deflection should be even across the squeegee blade.
4. To decrease the deflection of the squeegee blade at the ends, tighten knob near the squeegee center. To increase the deflection at the ends of the squeegee assembly, loosen knob.
5. Check the deflection of the squeegee blades again. Repeat steps 1 through 4 until the deflection is equal across the entire rear squeegee blade.

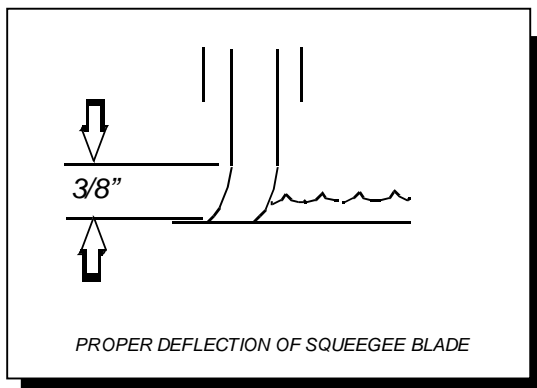

## TO ADJUST AMOUNT OF REAR SQUEEGEE DEFLECTION

1. Choose a smooth, level surface. Lower the squeegee and drive forward at least 2 feet (60cm).
2. With the squeegee down, stop the machine. Do not allow machine to roll back.

**FOR SAFETY: Before leaving or servicing machine; stop on level surface, turn off machine and remove key.**

3. Observe the amount of squeegee deflection. It should deflect 3/8 in. (9.5mm) across the entire width of the squeegee.
4. To increase the squeegee deflection, turn the 2 knobs at the squeegee ends counter-clockwise. To decrease the deflection, turn the knobs clockwise.

*NOTE: The deflection should be consistent along the length of the squeegee. If the deflection varies from end to end the knobs can be adjusted independently to correct the variation.*

5. Turn on the key switch. Raise, then lower squeegee assembly. Drive forward at least 2 feet (60cm).
6. Repeat steps 2 through 4 until deflection of 3/8 in. (9.5mm) is reached.

## 3. TO REPLACE AQUA-MIZER SQUEEGEE BLADES

These squeegee blades have two wear edges. To use the second edge:

1. Remove deck shrouds.
2. Remove brushes or pad drivers.
3. Remove each of the Aqua-Mizer squeegee systems.
4. Remove the hardware from each system that retains the blade.
5. Flip the blades and replace hardware.
6. Re-install each Aqua-Mizer system, brushes or pad drivers and shrouds.

## MAINTENANCE

### 4. SCRUB BRUSHES

There are four different types of brushes available to cover applications from cleaning heavily soiled floors to polishing. A pad driver is also available to take advantage of the many cleaning pads on the market. Please refer to the following to assist in selecting the proper brush or pad for the work at hand.

#### UNCOATED FLOORS

**Aggressive Grit** is a nylon fiber impregnated with silicone carbide grit. It grinds away stain, soil, and removes surface material.

**Mild Grit** is a less aggressive silicone carbide grit suitable for cleaning medium soil conditions. Advantages are faster ground speed than nylon bristles on light solid applications.

**Polypropylene** is a general-purpose scrub brush with stiff bristles. Polypropylene works well for maintaining concrete, wood and tile floors.

#### FINISHED FLOORS

**Nylon** bristles are used in a variety of applications on coated or uncoated surfaces.

**White Pads** (Polishing) are used for dry polishing to achieve a high-gloss appearance, or surface washing on highly polished or burnished floors.

**Red Pads** (Buffing) are used for light-duty scrubbing. When used with a mild detergent they will provide surface cleaning without removing the finish.

**Blue Pads** (Scrubbing) are used for heavy-duty scrubbing and light stripping. The blue pads remove less finish than brown stripping pads, yet will remove black marks, stains and dirt.

**Black Pads** (Stripping) are used for easy and complete removal of old floor waxes/finishes. They will quickly remove ground in dirt, black heel marks, and spills. When used with the proper stripper, this pad leaves the floor clean and ready for finishing.

The scrub brushes should be checked before each days work for wire, string, wear and damage.

### REPLACING OR INSTALLING SCRUB BRUSHES

1. With the scrub deck up, turn "OFF" the machine.

**FOR SAFETY: Before leaving or servicing the machine; stop on level surface, turn OFF machine and remove key.**

2. Remove the brush cover shrouds.
3. Locate release lever on top of brush or pad driver. Rotate release lever counter-clockwise and the brush/pad driver will release and drop down.
4. To reinstall, center the brush driver under the brush drive hub. Raise until it contacts brush driver assembly. Turn clockwise until release lever plate locks into position.
5. Replace the brush cover shrouds.

*NOTE: Check that release plate is completely closed and pad/brush is securely attached. Damage to driver or brush could occur.*

### 5. RECOVERY TANK FLOAT SHUT-OFF

When water is no longer being vacuumed from the floor and the vacuum fan is operating, the ball float has engaged. The vacuum motor will not vacuum water with recovery tank full. The recovery tank must be drained.

1. The float shut-off screen can be cleaned in or out of the machine.
2. To clean the float shut-off while it is inside the machine wipe material off screen then rinse. Check that the ball is also clean and moves freely.
3. To remove the float shut-off, grasp the screen with one hand and the connected tube with the other. Tilt and pull the float screen assembly to pull it off the barb on the tube.
4. To install, place one hand on the tube, and then tilt and push the float screen assembly over the barb on the tube.

## 6. SOLUTION STRAINER

The solution strainer is located in front of the left front wheel. The solution strainer protects the solenoid valve from debris. If there is little or no solution flow to the ground, check the strainer for debris. Drain the solution tank and clean the solution strainer. To remove the strainer, turn the bottom part of the strainer counterclockwise until the bottom is separated. Clean out the debris from the wire mesh and re-assemble. Make sure the O-ring gasket is in place when re-assembled.

## 7. BRUSH MOTOR



**Do not use a pressure washer to clean around the brush motors. Use tap pressure only.**

## CHANGING BRUSH MOTORS

1. With the scrub deck in the stored position, disconnect brush motor wiring connector from harness.
2. Remove shrouds from scrub deck to access and remove scrub brushes or pad drivers.
3. Remove retaining bolt, lock washer, flat washer and star drive from brush motor shaft.
4. Remove 4 brush motor mounting bolts located under scrub deck.
5. Remove brush motor.
6. Reverse steps to install.

## BRUSH MOTOR CARBON BRUSH REPLACEMENT

1. Scribe alignment mark on motor barrel to motor cap. Remove two bolts.
2. Remove end cap from motor.  
**NOTE:** Motors contain two wave washers in cap. Do not lose these.
3. Release brush from spring tension. Remove screw connecting brush wire lead to brush holder. Clean brush holder to insure free movement.
4. Retract spring and install new brush. Install connector screw and lead.
5. When all new brushes are installed. Place all in retracted position, held into brush holder by spring tension.
6. Carefully place end cap onto bearing on motor shaft.  
**NOTE:** Use care to assure wave washer alignment.
7. With end cap in partially installed position, release all brushes to contact position with motor commutator.

**NOTE:** Failure to insure all brushes are released will result in motor failure.

8. Reset end cap and realign with scribe marks on motor barrel. Reinstall the two attach bolts from cap into base.
9. Maintain alignment between motor barrel base and cap.

## GREASING AXLES

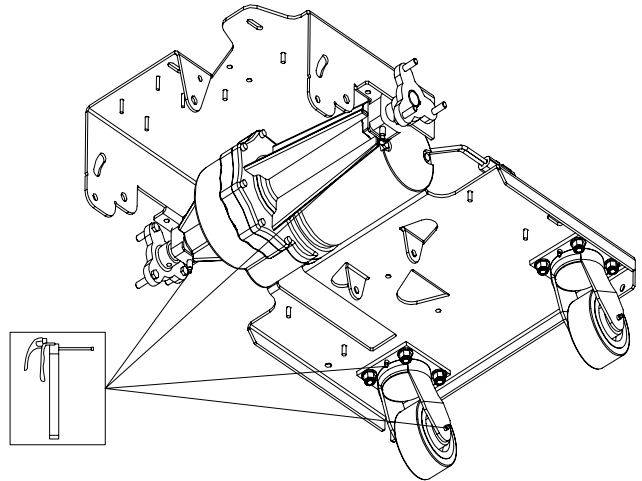

1-2 strokes of Mobiltemp®78 or compatible clay-based or calcium-based grease.

**NOTE:** Use hand operated grease gun only.

## MAINTENANCE

### 8. TRACTION MOTOR

#### **WARNING**

Do not use a pressure washer to clean around the motors. Use tap pressure only.

### TRACTION MOTOR CARBON BRUSH REPLACEMENT

*FOR SAFETY: Before leaving or servicing machine, stop on a level surface, turn off machine and remove key.*

1. Disconnect batteries from machine.
2. Disconnect the electrical connection to the traction motor.
3. Remove brush cap.
4. Release brush from spring tension. Remove screw connecting brush wire lead to brush holder. Clean brush holder to insure free movement.
5. Install new brush and reinstall connecting screw and lead.
6. When all new brushes are installed. Place all in retracted position, held into brush holder by spring tension.
7. Carefully replace brush cap onto bearing on motor shaft.

### 9. CIRCUIT BREAKERS

Circuit breakers interrupt the flow of power in the event of an electrical overload. When a circuit breaker is tripped, reset it by pressing the exposed button. If a circuit breaker continues to trip, the cause of the electrical overload should be found and corrected.

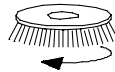

30 Amp. Protects the left scrub brush motor.

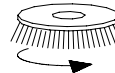

30 Amp. Protects the right scrub brush motor.



25 Amp. Protects the vacuum motor.



25 Amp. Protects the propel motor.



3 Amp. Protects the machine controls.

### 10. BRUSH SHROUDS & BRUSH SKIRTS

Contain the water in the shroud area. The skirt will flex over uneven floors and also as the brush or pad wears. As the brush wears the shrouds can be adjusted so that skirt does not have to flex so much.

Remove three bolts on each side that fasten the bracket to the cover and re-assemble in the top holes. When the brushes are replaced with new ones move the covers back to the lower set of holes.

## 11. VACUUM MOTOR

(Refer to the Vacuum Group in the parts section of manual)

### **⚠ WARNING**

**Do not use a pressure washer to clean around the vacuum motors. Use tap pressure only. Care must be taken so that water is not directed into vacuum motor air intakes.**

### CHANGING VACUUM MOTOR

1. Disconnect batteries from machine.
2. Remove front cover.
3. Disconnect electrical connector to the vacuum motor.
4. Loosen clamp and disconnect hose from vacuum intake.
5. Remove vacuum motor mounting bracket bolts.
6. Remove vacuum motor from mounting bracket.
7. Reverse steps to install.

#### Vacuum Motor Carbon Brushes Replacement (Windsor)

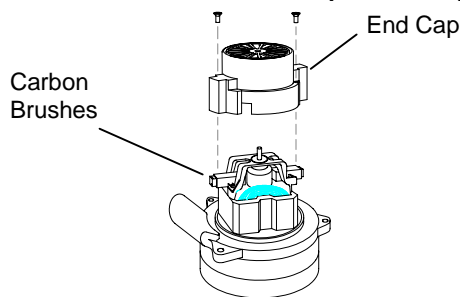

If armature commutator is grooved, extremely pitted or not concentric, the motor will need to be replaced or sent to a qualified service center.

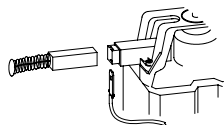

#### **Important:**

*These brushes wear quicker as the length shortens due to increased heat. Spring inside brush housing will damage motor if brushes are allowed to wear away completely.*

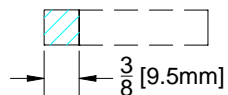

Periodically check the length of the carbon brushes. Replace both carbon brushes when either is less than 3/8" (9.5mm) long.

#### Vacuum Motor Carbon Brushes Replacement(Ametek)

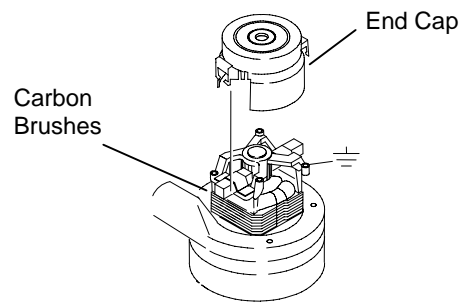

If armature commutator is grooved, extremely pitted or not concentric, the motor will need to be replaced or sent to a qualified service center.

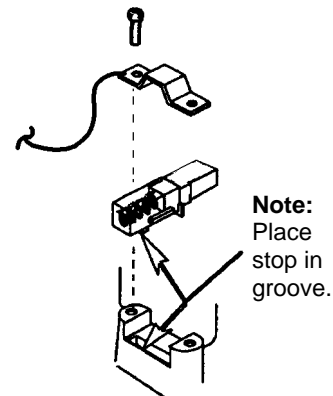

**Note:**  
Place stop in groove.

#### **Important:**

*These brushes wear quicker as the length shortens due to increased heat. Spring inside brush housing will damage motor if brushes are allowed to wear away completely.*

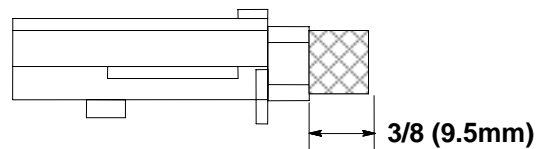

Periodically check the length of the carbon brushes. Replace both carbon brushes when either is less than 3/8" (9.5mm) long.

## MACHINE TROUBLESHOOTING

PROBLEM	CAUSE	SOLUTION
Poor or no water pick-up	Squeegee out of adjustment	Adjust squeegee
	Debris caught on squeegee	Remove debris
	Worn squeegee blades	Rotate or replace squeegee blades
	Vacuum hose clogged	Clear obstruction from hose
	Vacuum hose disconnected from squeegee or recovery tank	Reconnect vacuum hose
	Vacuum hose damaged	Replace vacuum hose
	Recovery tank not sealed	Place recovery tank dome on tank. Replace damaged gaskets.
	Foam filling recovery tank	Empty recovery tank Use less or different detergent Use defoamer
Vacuum motor does not run, or runs slowly	Recovery tank full	Drain recovery tank
	Recovery tank float system dirty	Clean float system
	Circuit breaker tripped	Reset circuit breaker
	Loose connection	Check motor wires and connections
	Faulty vacuum switch	Replace switch
	Worn vacuum motor brushes	Replace brushes, check commutator
Poor scrubbing performance	Debris caught in scrub brushes	Remove debris
	Worn brushes or pads	Replace brushes or pads
	Improper detergent, brush or pad used	Contact equipment or application specialist
	Low scrub brush down pressure	Increase brush pressure
	Low battery charge	Charge batteries
Brush motors do not run, or runs slowly	Circuit breaker(s) tripped	Reset circuit breaker(s)
	Loose connection	Check motor wires and connection
	Faulty brush motor contactor	Replace contactor
	Worn brush motor brushes	Replace brushes, check commutator

## MACHINE TROUBLESHOOTING

<b>PROBLEM</b>	<b>CAUSE</b>	<b>SOLUTION</b>
Little or no solution flow to the floor	Solution tank empty	Fill solution tank
	Solution flow turned off or set too low	Turn on or increase flow setting
	Solution strainer plugged	Clean solution strainer
	Solution hoses obstructed	Clear obstruction from hose
	Solution solenoid valve obstructed or stuck	Clean or replace
	Vent hole in solution tank lid obstructed	Clear obstruction from vent hole
No power to machine	Battery disconnected	Check all battery cable connections
	Emergency shut-off activated (If included)	Reset
	Battery connections corroded	Clean connections
	Faulty main contactor	Replace contactor
	Faulty key switch	Replace switch
Little or no propel	Low battery charge	Charge batteries
	Wheels spin	Decrease brush pressure
	Controller overheated	Allow cool down period Adjust brush shroud if needed
	Loose connection	Check motor wires and connection

# CONTROL HANDLE

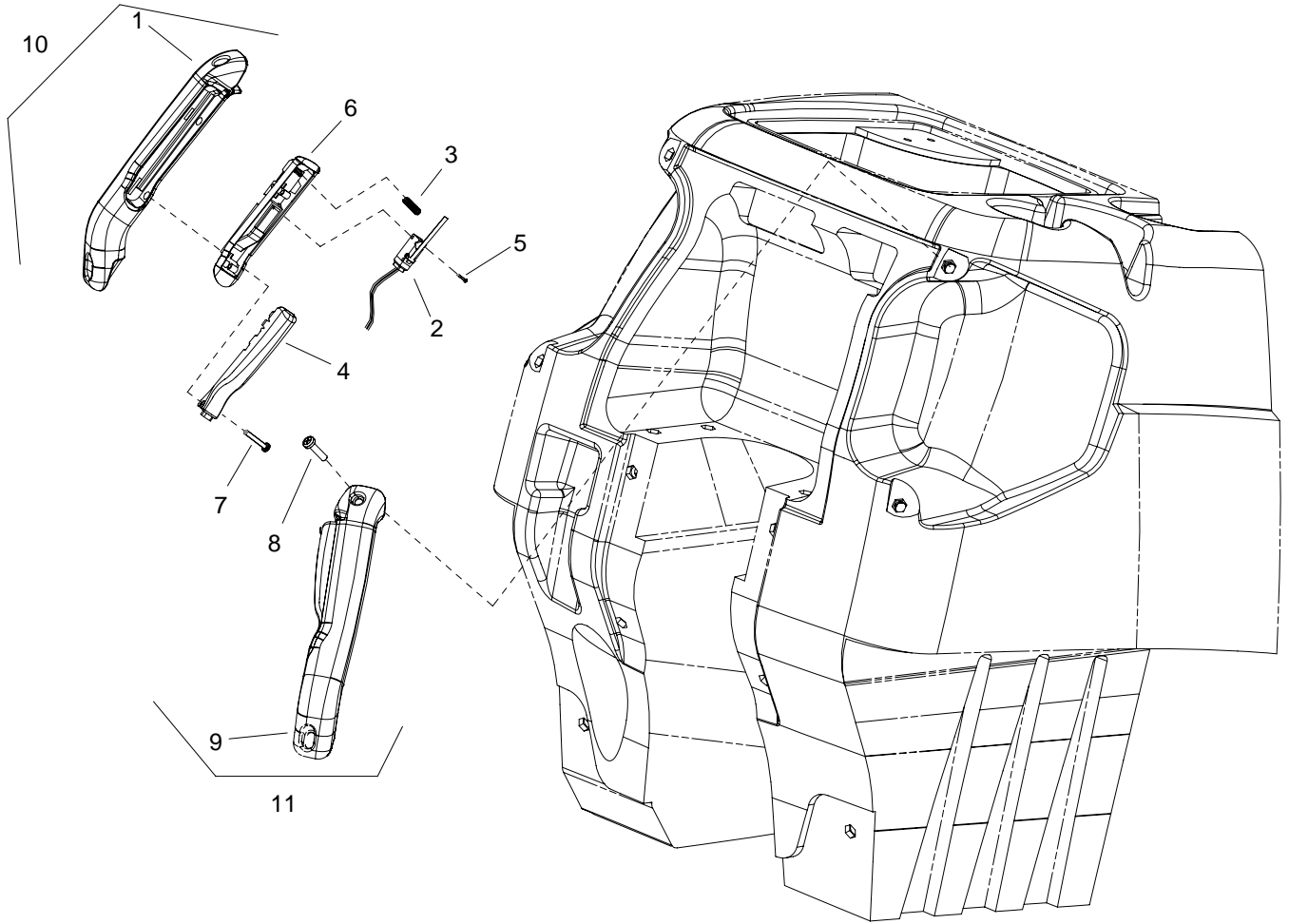

## CONTROL HANDLE

REF	PART NO.	PRV NO.	QTY	DESCRIPTION	SERIAL NO. FROM	NOTES:
1	86238730	38307	1	HANDLE, LEFT		
2	86257230	730125	2	SWITCH, SPST MOM NO W/LEVER		
3	86254920	730153	2	SPRING, COMP .240D X 1.25 X .018		
4	86231480	140504	2	BUTTON, PROPEL		
5	86277070	70784	2	SCR, 4-40 X 5/8 PPHMS		
6	86240990	41431	2	HOUSING, BUTTON		
7	86277060	70783	4	SCR, 8-32 X 7/8 PHTC TYPE 23		
8	86277050	70782	4	SCR, 5/16-18 X 3/4 SHCS NP		
9	86238740	38308	1	HANDLE, RIGHT		
10	86004120	38312	-	PROPEL HANDLE ASM, LEFT		SERVICE ONLY
11	86004130	38313	-	PROPEL HANDLE ASM, RIGHT		SERVICE ONLY

# COVER (FRONT) & TANK MOUNT

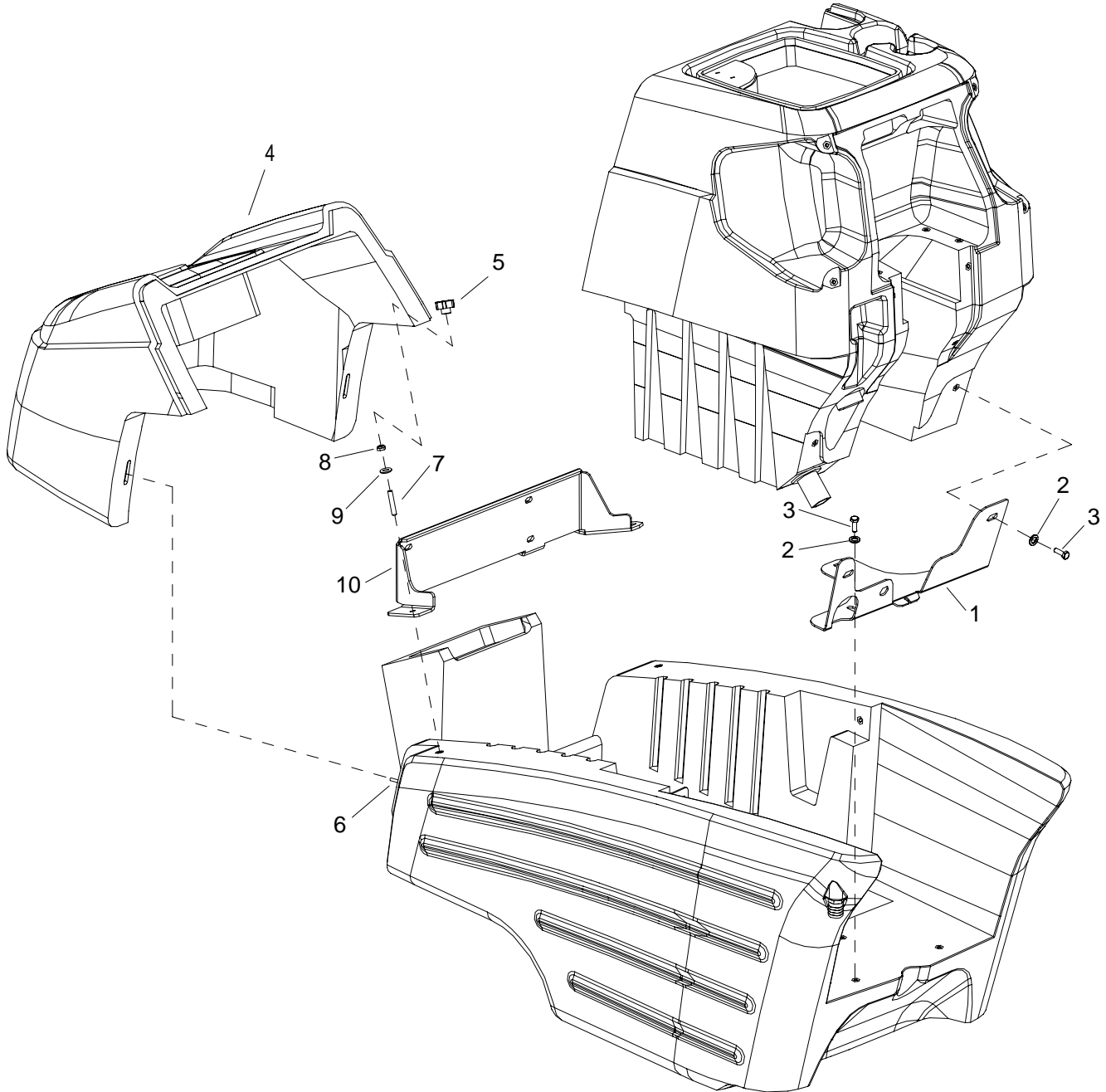

## COVER (FRONT) & TANK MOUNT

REF	PART NO.	PRV NO.	QTY	DESCRIPTION	SERIAL NO. FROM	NOTES:
1	86073690	140576	2	BRT, REC TO W/BRAKE 36V		
2	86010670	87029	2	WASHER, 5/16 FLAT SS		
3	86276780	70728	5	SCR, 5/16-18 X 3/4 HHCS SS		
4	86062530	27927	1	COVER, FRONT 36V GRY		
5	86004790	48012	2	KNOB, 5/16-18 4 PRONG		
6	86276380	70639	4	SCR, 5/16-18 X 1.25 SSSCU		
7	86278080	87212	3	WASHER, .344ID X 1.13OD X .09T PLTD		
8	86065990	05256	1	ARM, TANK SUPPORT		
9	86010720	87086	1	WASHER, M10 X 30 PLTD		
10	86276920	70755	1	SCR, 5/16-18 X 2 HHCS SS		

# COVER (TOP) & TANK MOUNT

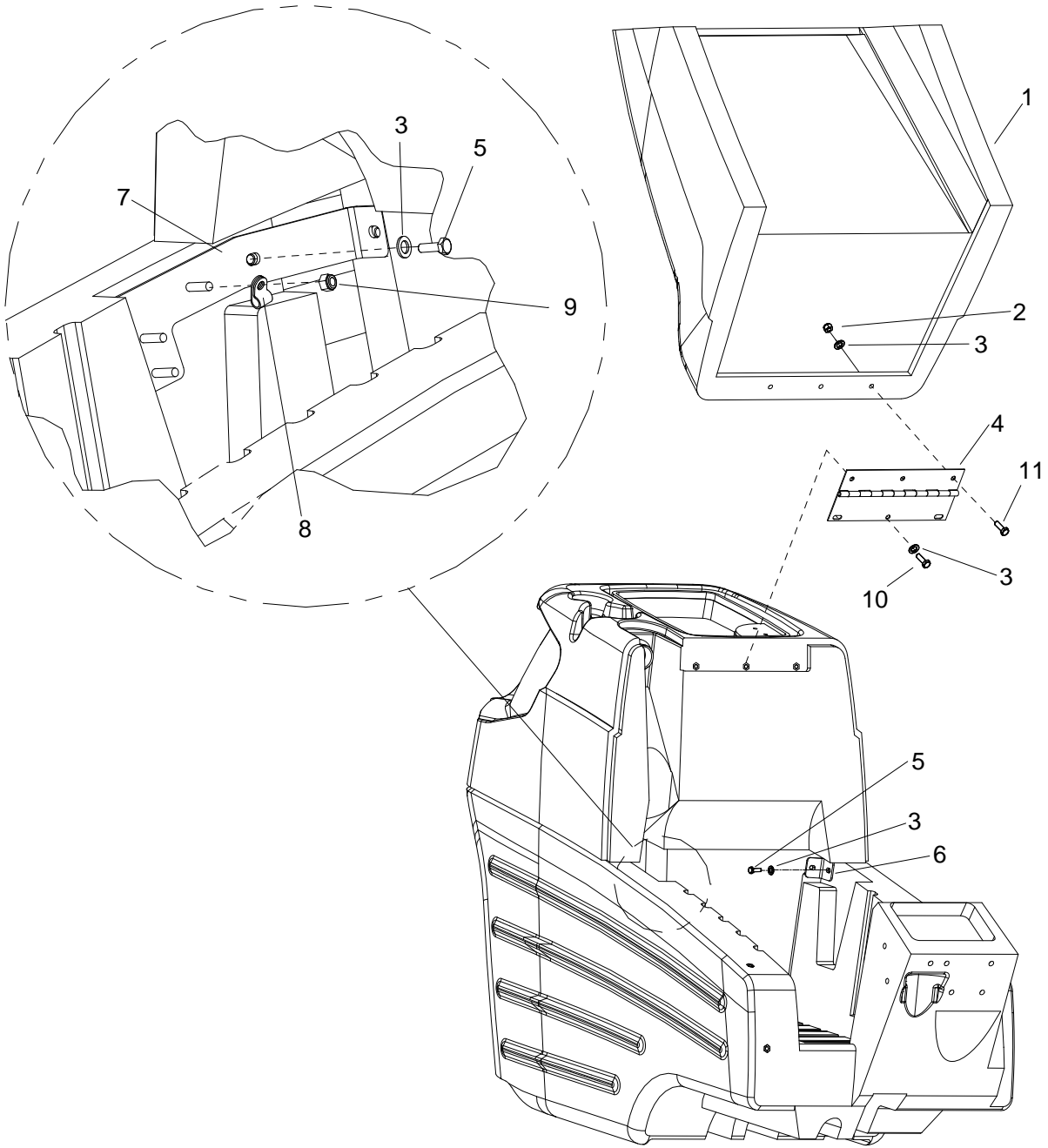

## COVER (TOP) & TANK MOUNT

REF	PART NO.	PRV NO.	QTY	DESCRIPTION	SERIAL NO. FROM	NOTES:
1	86062560	27928	1	COVER, TOP 36V GRY		
2	86271840	57285	3	NUT, 5/16-18 HEX NYLOCK THIN SS		
3	86010670	87029	10	WASHER, 5/16 FLAT SS		
4	86239650	41432	1	HINGE, COVER TO TANK		
5	86276780	70728	4	SCR, 5/16-18 X 3/4 HHCS SS		
6	86069840	140525	1	BRACKET, TANK LEFT		
7	86069850	140526	1	BRACKET, TANK RIGHT		
8	86233390	80887	1	CLAMP, 7/8 DIA "P" CUSHIONED		
9	86271870	57290	1	NUT, 1/4-20 HEX NYLOCK THIN SS		
10	86276490	70670	3	SCR, 5/16-18 X 5/8 HHCS SS		
-	86292630	-	1	NET, CARGO		NOT SHOWN
11	86276780	70728	3	SCR, 5/16-18 X 3/4 HHCS SS		

**DECAL**

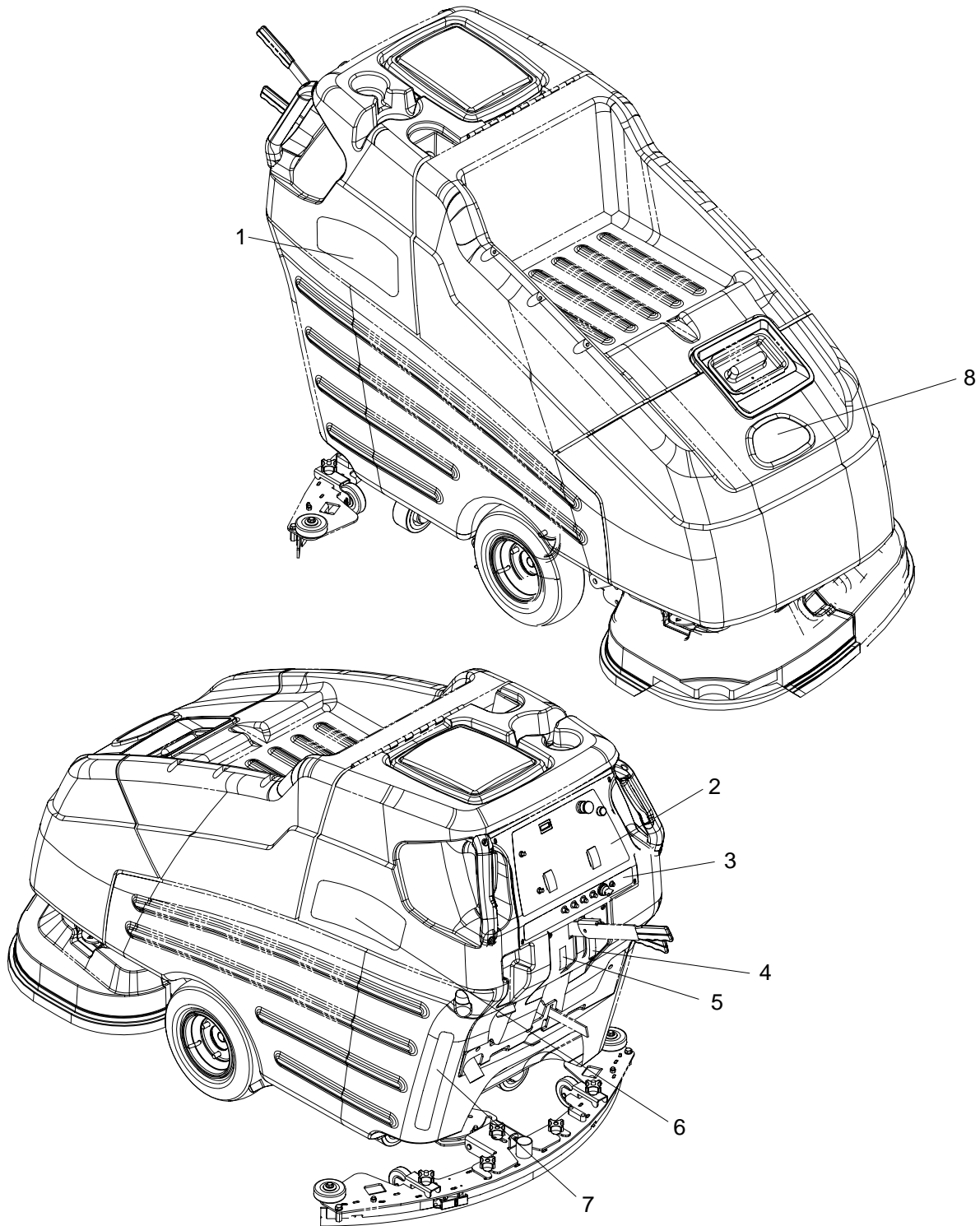

**DECAL**

REF	PART NO.	PRV NO.	QTY	DESCRIPTION	SERIAL NO. FROM	NOTES:
1	86243560	500573	1	LABEL, CUTTER RIGHT		
2	86243620	500580	1	LABEL, ELEC. PANEL 36V BASIC		
3	86243610	500579	1	LABEL, ELEC. PANEL. LOWER 36V		
4	86243600	500578	1	LABEL, SQUEEGEE LEVER		
5	86243590	500577	1	LABEL, BRUSH LEVER		
6	86243550	500572	1	LABEL, CUTTER LEFT		
7	86243170	500625	1	LABEL, SOLUTION FILL 36V		
8	86004970	50990	1	LABEL, WINDSOR LOGO DOMED		

# ELECTRICAL PANEL

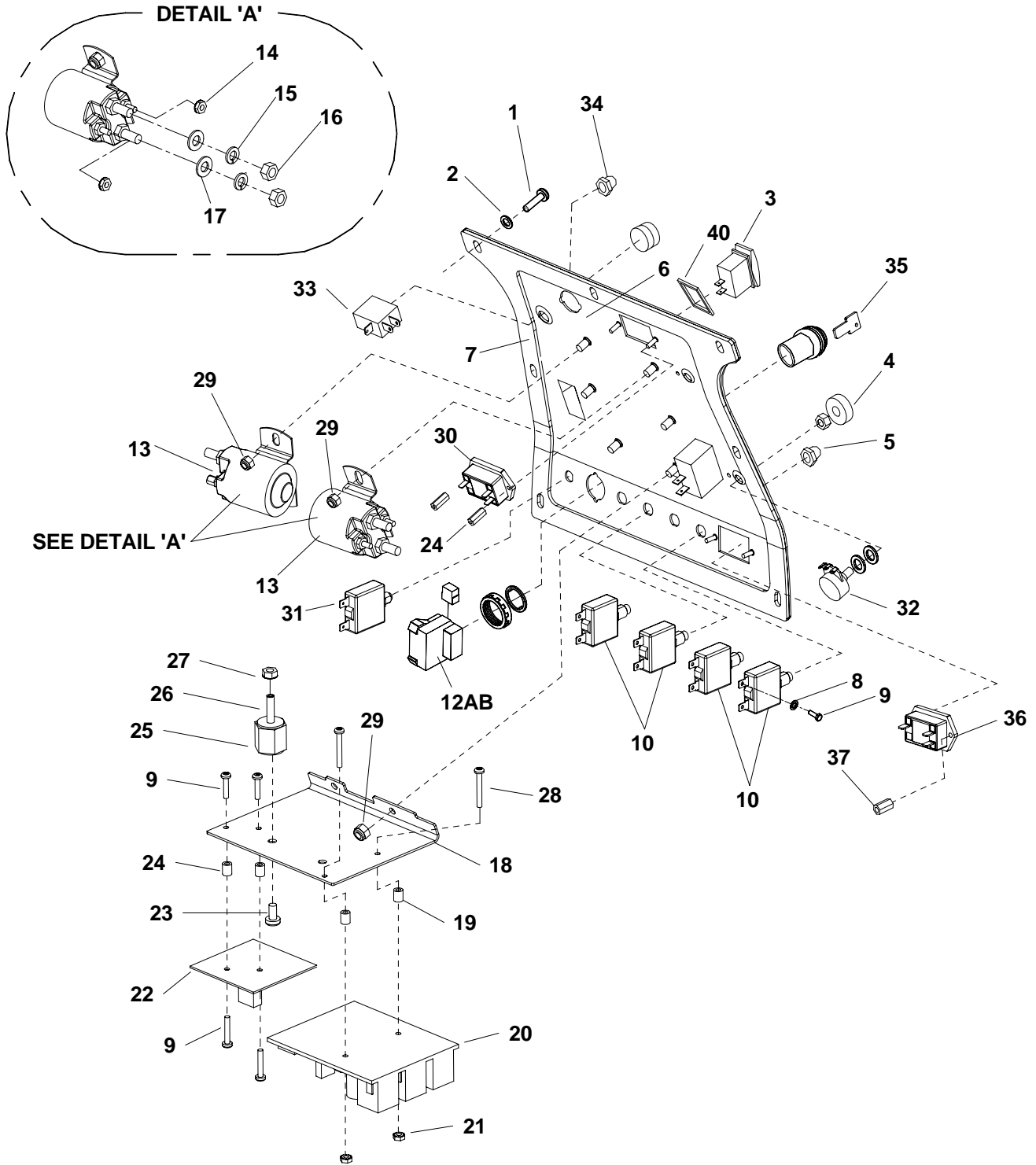

## ELECTRICAL PANEL

REF	PART NO.	PRV NO.	QTY	DESCRIPTION	SERIAL NO. FROM	NOTES:
1	86276290	70626	7	SCR, #10 X 3/4 PPHST HI-LO BLK		
2	86294250	-	7	WASHER, .19 1D X .5 X .09TK BLK		
3	86007140	72130	2	SWITCH, SPST 2-POSITION ROCKER		
4	86242110	48088	2	KNOB, .90OD X .25 COLLET		
5	86008900	80845	4	BOOT, SEAL-PUSH BUTTON 7/16-28		
6	86082850	66367	1	PLATE, ELEC PANEL 24 V BASIC		
7	86237820	35263	1	GASKET, ELEC PLATE		
8	86279300	87134	8	WASHER, #6 LOCK		
9	86273990	70067	12	SCR, 6-32 X 3/8 PPHMS		
10	86001910	14606	4	BREAKER, 30A 250VAC 50VDC		
11	-	OPEN	-	-		
12A	86007170	72159	1	SWITCH, KEY 2-POSITION		
12B	86193750	32-900205	-	SWITCH, PADDLE 2-POSITION		OPTIONAL
13	86006370	67315	2	RELAY, 36VDC 100AMP HEAVY DUTY		
14	86005700	57104	4	NUT, 10-32 HEX W/ STAR		
15	86279480	87166	4	WASHER, 5/16 EXT LOCK PLTD		
16	86271080	57117	4	NUT, 5/16-24 HEX PLTD		
17	86010760	87142	2	WASHER, .344 X .69 X .066 FLAT PLT		
18	86082820	66353	1	PLATE, ELEC PANEL BACK		
19	86254440	73734	2	SPACER, .166ID X .313OD X .375L AL		
20	86002940	27672	1	CONTROLLER, 36VDC PROPEL MOTOR		
21	86270850	57026	2	NUT, 8-32 HEX NYLOCK SS		
22	86003250	27944	1	CIRCUIT BOARD, SOL/FLOAT WIRED		
23	86276880	70751	1	SCR, 1/4-20 X 3/8 HHCS SS		
24	86255890	730164	2	STANDOFF, 6-32 X 1.0 HEX NYL		
25	86255910	73659	1	STANDOFF, 1/4-20 X 1.0 HEX INS		
26	86006850	70393	1	SCR, 1/4-20 X 1.25 SSSCU		
27	86005710	57105	1	NUT, 1/4-20 HEX W/STAR WASHER		
28	86273910	70045	2	SCR, 8-32 X 1 PPHMS		
29	86271870	57290	6	NUT, 1/4-20 HEX NYLOCK THIN SS		
30	86246930	54144	1	METER, 36V BATTERY CHARGE LEVEL		
31	86002000	14717	1	BREAKER, 3A 250VAC 50VDC		
32	86006310	66335	1	POTENTIOMETER, 50K OHMS		SERVICE ONLY
33	86257030	72168	1	SWITCH, MOMENTARY DPST		
34	86257030	14942	1	BOOT, 3/8 CIRCUIT BREAKER		
35	86004860	48073	1	KEY, SWITCH		SERVICE ONLY
36	86005530	54154	4	STANDOFF, 6-32 X 5/8 HEX NYL	1000096610	
37	86255900	73538	1	METER, 12-48 VDC LED HOUR	1000099610	
38	86267340	880269	2	WIRE, 22" RED/18 76040 X 76075	1000099610	NOT SHOWN
39	86267360	880271	1	WIRE, 14" BLK/18 76011 X 76040	1000099610	NOT SHOWN
40	86238030	36235	2	GASKET, SWITCH CARLING		

# LIFT HANDLE

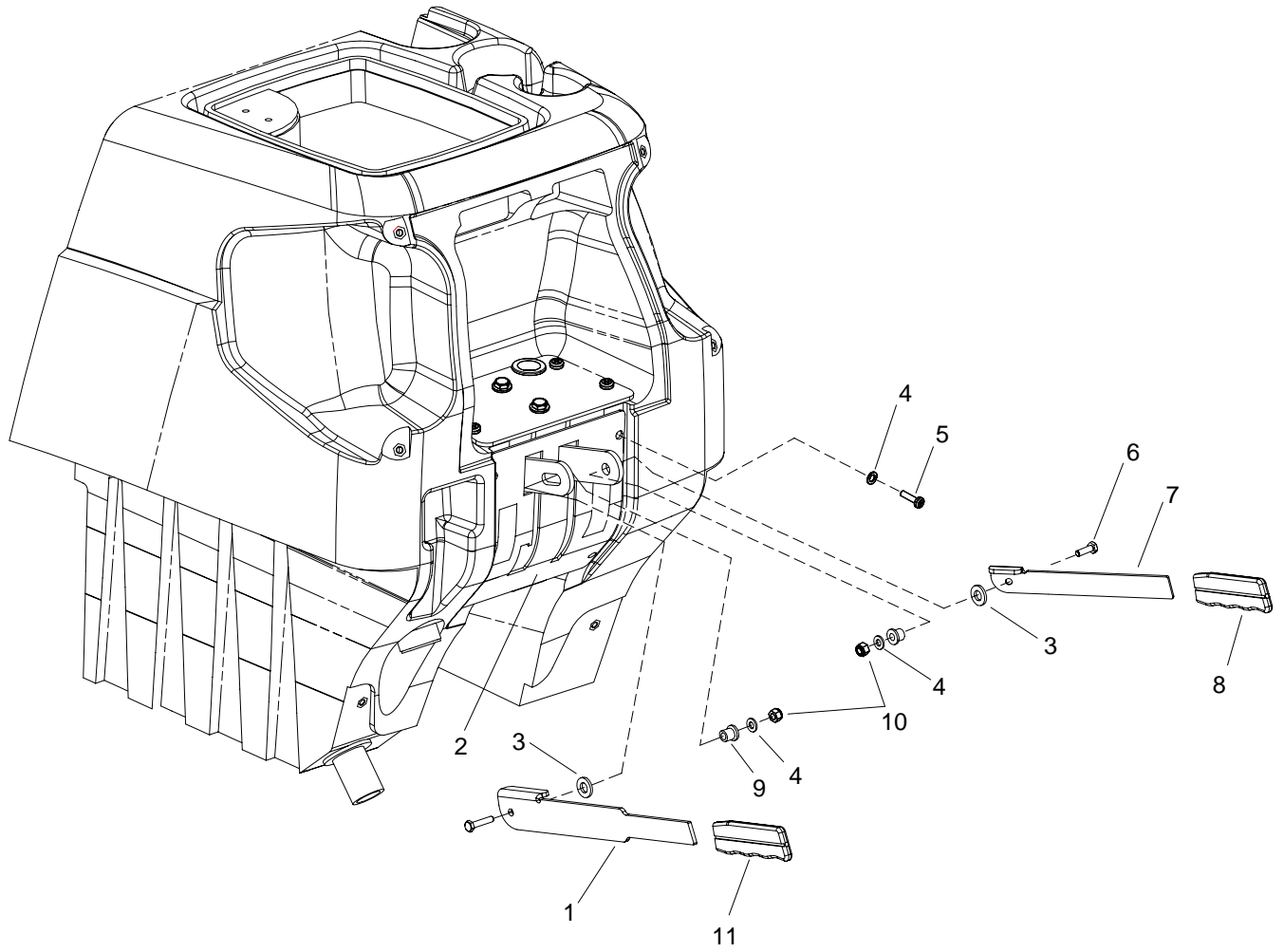

**LIFT HANDLE**

REF	PART NO.	PRV NO.	QTY	DESCRIPTION	SERIAL NO. FROM	NOTES:
1	86077260	51364	1	LEVER, DECK SWING		
2	86082900	66373	1	PLATE, LEVER NOTCH, 36V BASIC		
3	86259400	87205	2	WASHER, THRUST .51ID X 1OD BRO		
4	86010670	87029	6	WASHER, 5/16 FLAT SS		
5	86276780	70728	4	SCR, 5/16-18 X 3/4 HHCS SS		
6	86006930	70514	2	SCR, 5/16-18 X 1.00 BSHCS SS		
7	86066860	140537	1	BAR, SQG LIFT SWING		
8	86238360	36215	1	GRIP, 3/16 X 1.0 ORANGE		
9	86228840	09124	2	BEARING, FLANGED .314ID X .502OD		
10	86271840	57285	2	NUT, 5/16-18 HEX NYLOCK THIN SS		
11	86238350	36214	1	GRIP, 3/16 X 1.0 BLUE		

# LIFT HANDLE LINKAGE

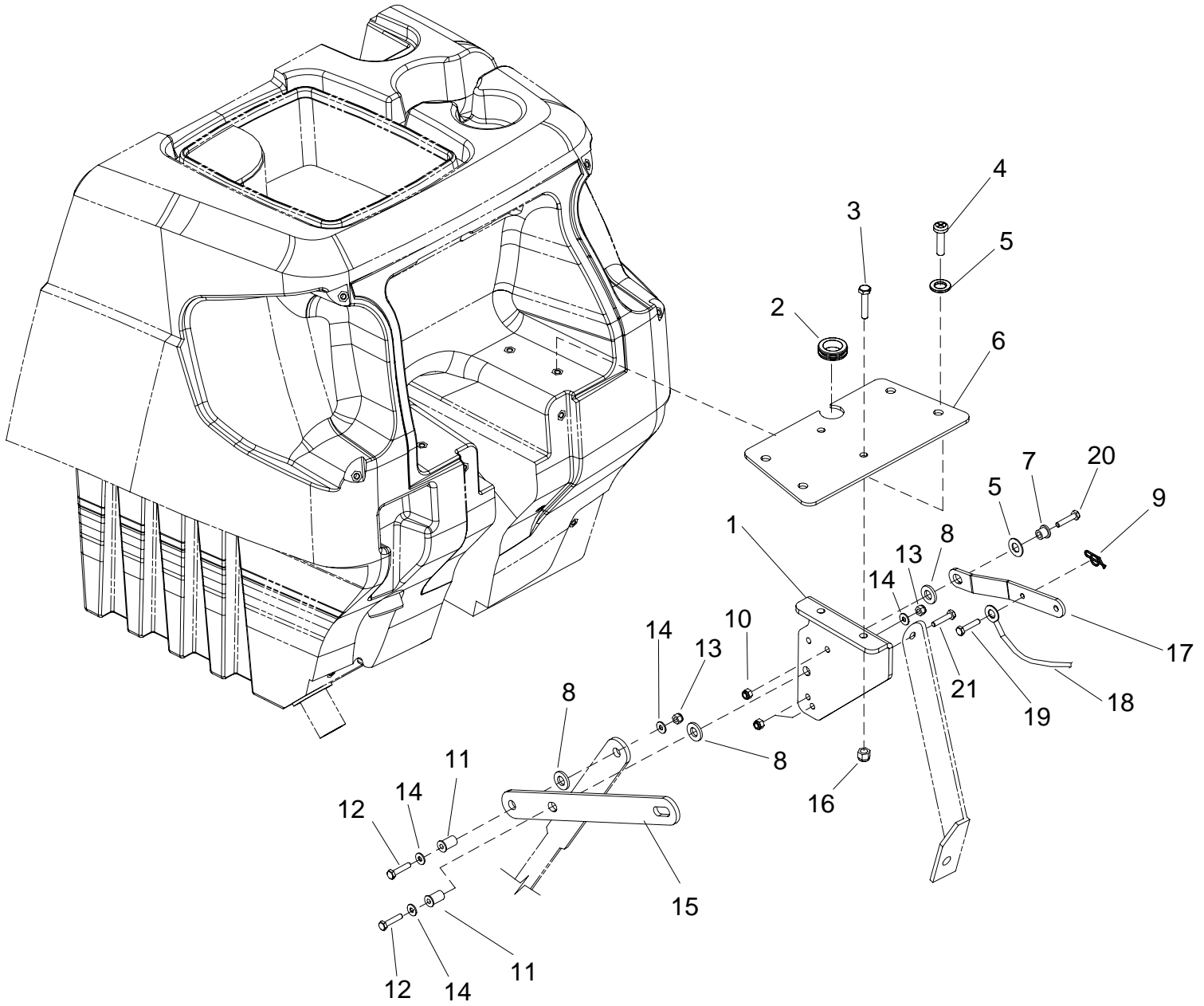

## LIFT HANDLE LINKAGE

REF	PART NO.	PRV NO.	QTY	DESCRIPTION	SERIAL NO. FROM	NOTES:
1	86069830	140524	1	BRKT, LEVER, PIVOT BOTTOM 36V		
2	86238430	36191	1	GROMMET 1.00 ID 3/16 GRIP		
3	86276920	70755	2	SCR, 3/8-16 X 1 HHCS SS NP		
4	86276780	70728	5	SCR, 5/16-18 X 3/4 HHCS SS		
5	86010670	87029	5	WASHER, 5/16 FLAT SS		
6	86082890	66372	1	PLATE, PIVOT TOP		
7	86228840	09124	1	BEARING, FLANGED .314 D X .502 OD		
8	86259400	87205	3	WASHER, THRUST .51 ID X 1 OD BRO		
9	86179800	80604	1	COTTER, 1/4" RING		
10	86271840	57285	2	NUT, 5/16-18 HEX NYLOCK THIN SS		
11	86228900	09138	2	BEARING FLANGED .252ID X .503 OD		
12	86273820	70019	2	SCR, 1/4-20 X 1.25 HHCS		
13	86271870	57290	2	NUT, 1/4-20 HEX NYLOCK THIN SS		
14	86010630	87013	4	WASHER, 1/4 ID X 5/8 OD SS		
15	86077210	140516	1	BAR, DECK LIFT FIXED, 36V		
16	86005630	57022	2	NUT, 3/8-16 HEX NYLOCK THIN SS		
17	86077210	140536	1	LEVER, SQG LIFT FIXED		
18	86003240	27942	1	CABLE, .125X26.5, 0707,XX,LB,E-E		
19	86009560	82053	1	PIN, CLEVIS 1/4 X 5/8 PLTD		
20	86007020	70673	1	SCR, 5/16-18 X 1.25 HHCS SS		
21	86006560	70083	1	SCR, 5/16-18 X 1 HHCS SS NP		

# RECOVERY TANK

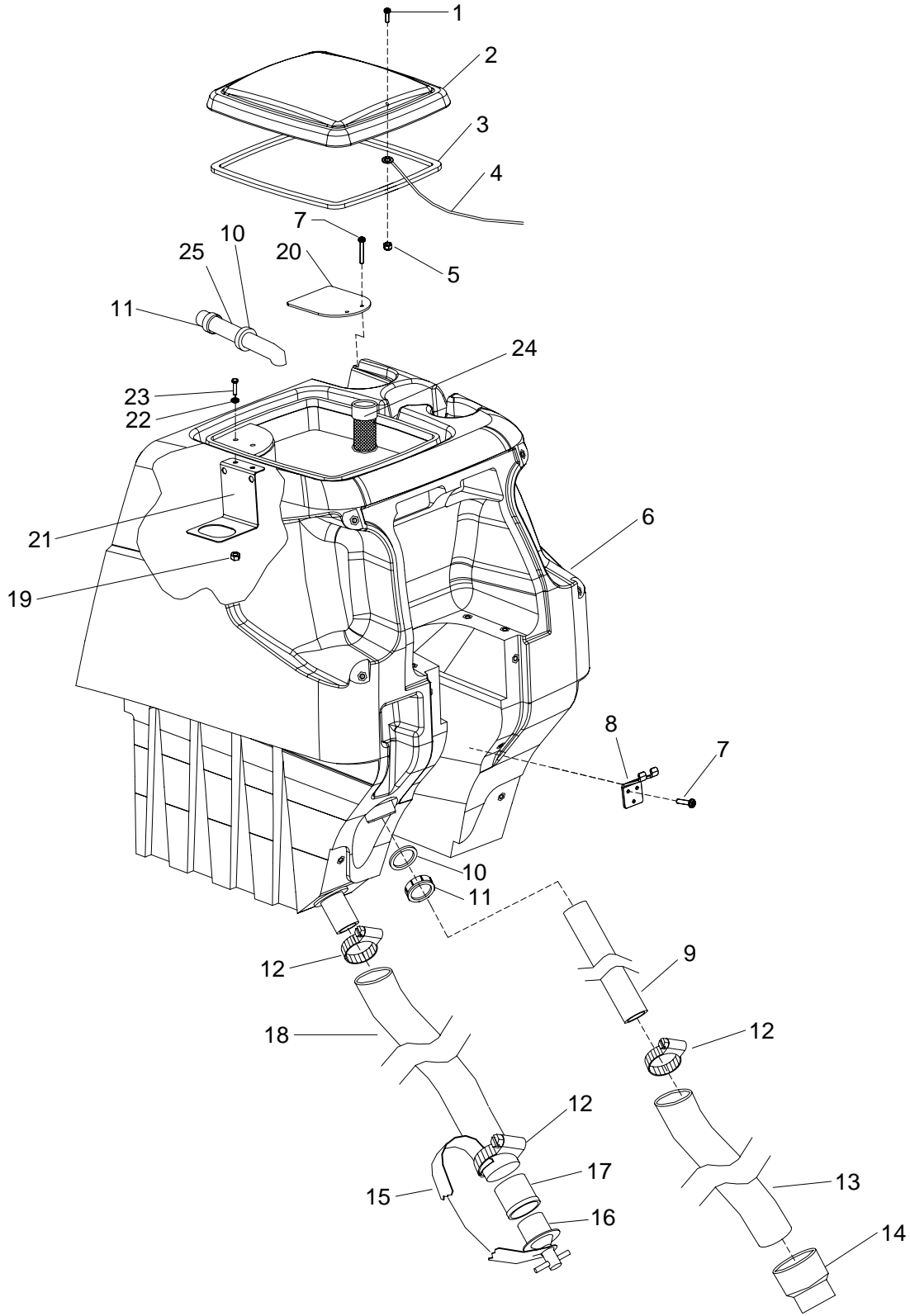

## RECOVERY TANK

REF	PART NO.	PRV NO.	QTY	DESCRIPTION	SERIAL NO. FROM	NOTES:
1	86273950	70056	1	SCR, 6-32 X 1/2 PPHMS		
2	86003340	28062	1	DOME, 13 X 11		
3	86003990	35250	1	GASKET, DOME		
4	86246080	51368	1	LANYARD, 18.0 W/ LOOP & EYE		
5	86270920	57049	1	NUT, 6-32 HEX NYLOCK SS		
6	86032560	75373	1	TANK, REC, 36V, GRY		
7	86276290	70626	5	SCR, #10 X 3/4 PPHST HI-LO BLK		
8	86001190	140133	1	BRACKET, RECOVERY HOSE MTG		
9	86089630	78490	1	TUBE, 1.5 PVC X 24.0		
10	86237650	35219	2	GASKET, 1-1/2 COMPRESSION		
11	86005660	57033	2	NUT, 1.5 SLIP JOINT		
12	86002400	20064	3	CLAMP, 2.0" WORM GEAR X .312W		
13	86004180	39315	1	HOSE, 1.5 BLK VAC X 28"		
14	86002840	27282	1	CUFF, 1.5 SLIP X 1.5 HOSE		
15	86008400	78499	1	TETHER, DRAIN PLUG		
16	86006240	66227	1	PLUG, DRAIN HOSE		
17	86004450	40019	1	HOSEBARB, 1.5 DOUBLE MCHD		
18	86004260	39472	1	HOSE, 1.5 X 24.0 DRAIN		
19	86271870	57290	2	NUT, 1/4-20 HEX NYLOCK THIN SS		
20	86075540	27941	1	COVER, VACUUM HOSE		
21	86069780	140511	1	BRACKET, VAC INTAKE		
22	86010630	87013	2	WASHER, 1/4ID X 5/8OD SS		
23	86273810	70018	2	SCR, 1/4-20 X 1 HHCS SS		
24	86236410	34394	1	FLOAT, VAC SHUT OFF		
25	86257860	78390	1	TUBE, 1.5 WASTE		

# SCRUB BRUSH/PAD DRIVER 32 IN

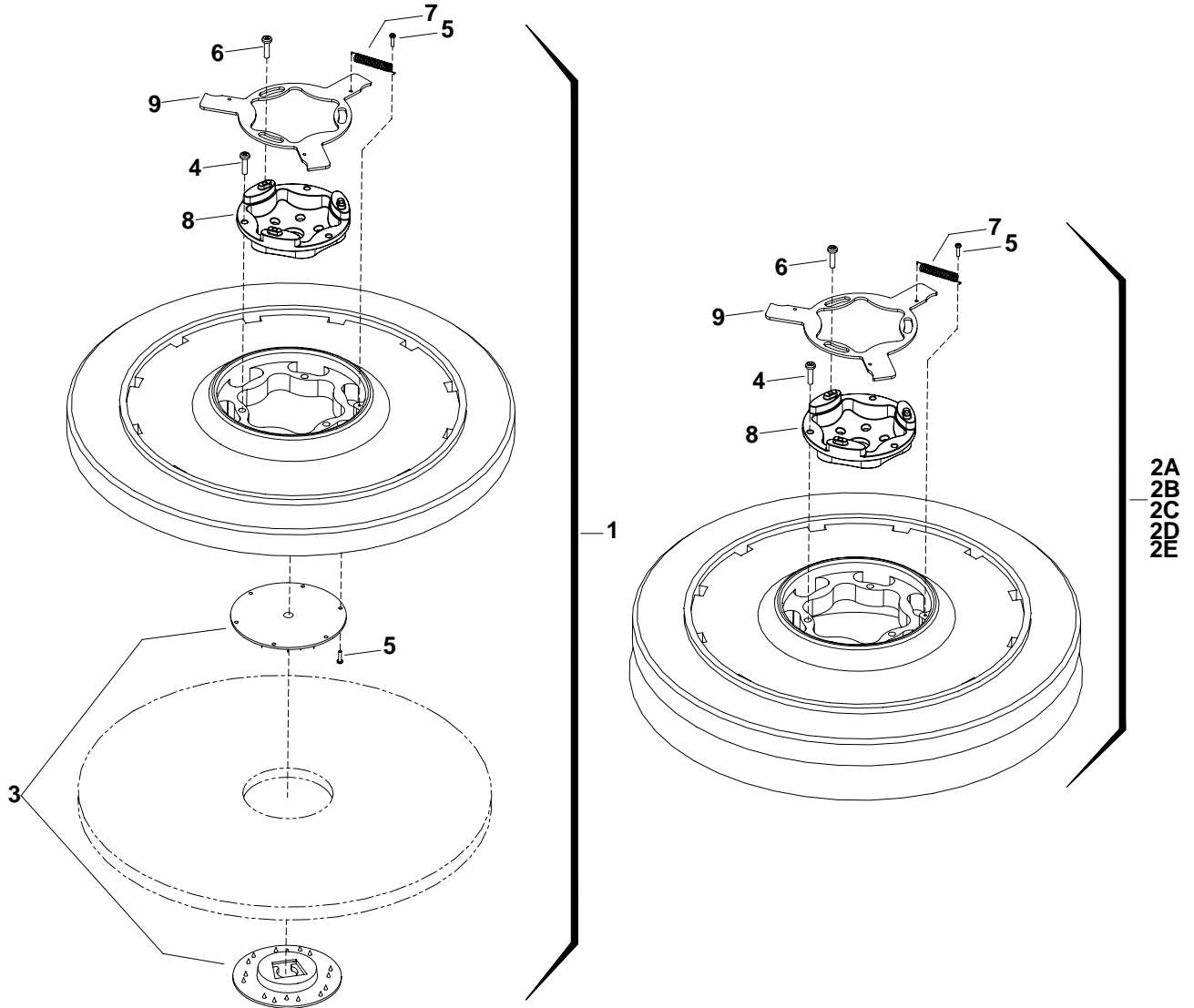

## SCRUB BRUSH/PAD DRIVER 32 IN

REF	PART NO.	PRV NO.	QTY	DESCRIPTION	SERIAL NO. FROM	NOTES:
1	86000290	02418	2	PAD DRIVER, 16" SD		
2A	86000300	02419	2	BRUSH, 16" POLYPROPYLENE SD		
2B	86000310	02420	2	BRUSH, 16" NYLON SD		
2C	86000320	02421	2	BRUSH, 16" NYLON POLISH SD		
2D	86000330	02422	2	BRUSH, 16" MILD GRIT SD		
2E	86000340	02423	2	BRUSH, 16" SUPER AGG SD		
3	86005070	51284	1	LOCK, PAD CENTER SNAP, TWO STEP		
4	86276590	70695	3	SCR, 12-24 X 1.0 PPHMS SS		
5	86276580	70694	4	SCR, 8-32 X 3/4 PTHMS		
6	86276600	70696	3	SCR, 10-32 X 3/4 PTHMS		
7	86007910	73817	1	SPRING, EX .31 D X 2.0 L X .03 W SS		
8	86007280	730011	1	SOCKET, DRIVE BRUSH		
9	86005940	62852	1	PLATE, BRUSH RELEASE		

# SCRUB DECK AQUA-MIZER

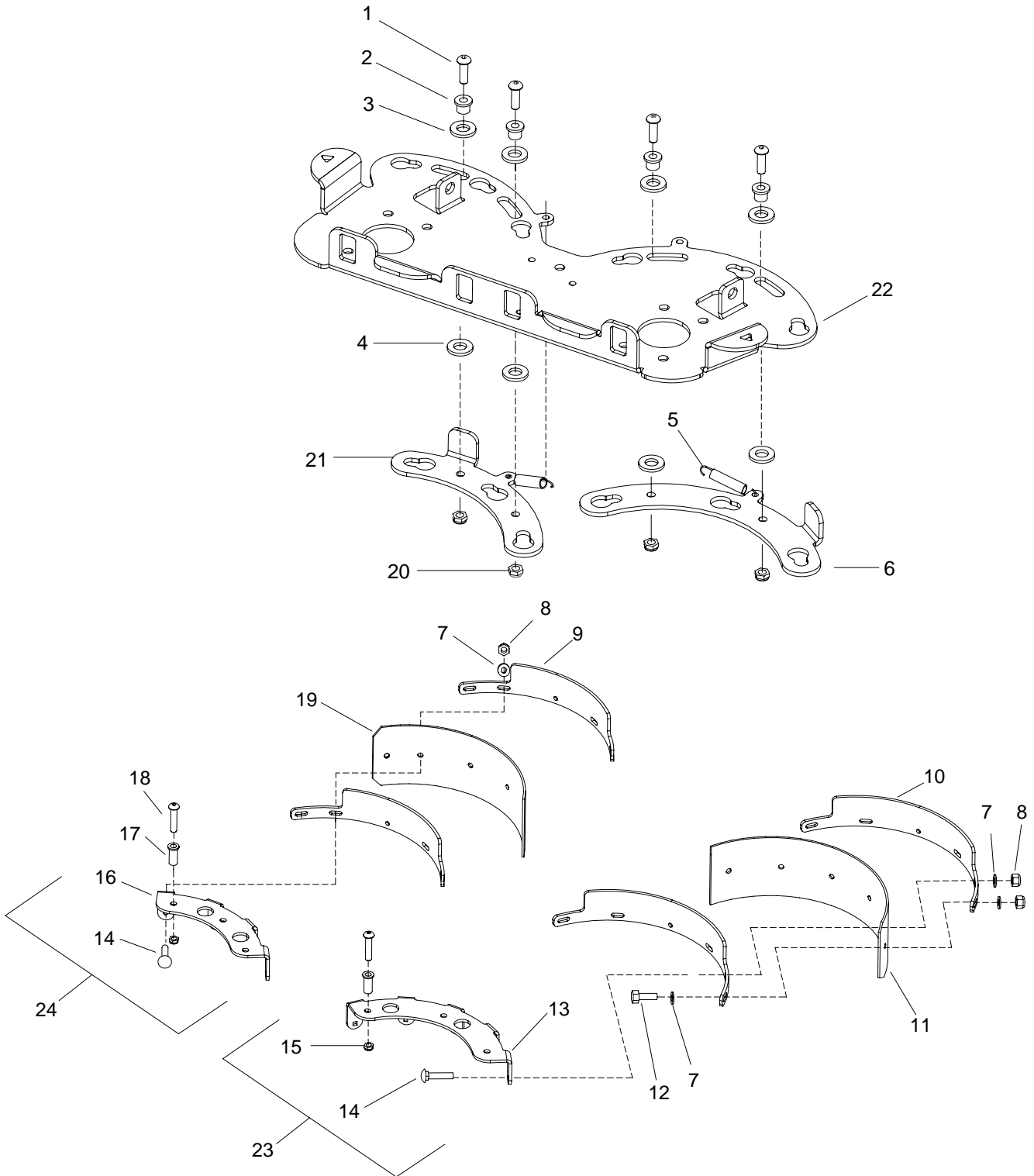

## SCRUB DECK AQUA-MIZER

REF	PART NO.	PRV NO.	QTY	DESCRIPTION	SERIAL NO. FROM	NOTES:
1	86006930	70514	4	SCR, 5/16-18 X 1.00 BSHCS SS		
2	86228840	09124	4	BEARING, FLANGED .314 ID X .502 OD		
3	86259420	87232	4	WASHER, THRUST .51 ID X 1 OD BRO		
4	86259400	87205	4	WASHER, THRUST .51 ID X 1 OD BRO		
5	86255060	73426	2	SPRING, EXT. .43D X 2.50L X .047W		
6	86249590	66374	1	PLATE, AQ LOCK LEFT 16 IN		
7	86010630	87013	13	WASHER, 1/4 ID C 5/8 OD SS		
8	86271870	57290	11	NUT, 1/4-20 HEX NYLOCK THIN SS		
9	86256020	730131	2	STRAP, AQ, BACK,L 16 INCH		
10	86256010	730130	2	STRAP, AQ, BACK, R 16 INCH		
11A	86001430	140528	1	BLADE, AQ LEFT 16 INCH		
11B	86135160	730429	1	BLADE, AQ LT 16 INCH URETHANE		
12	86273810	70018	2	SCR, 1/4-20 X 1 HHCS SS		
13	86249530	66370	1	PLATE, AQ ATTACH L, 16"		
14	86276960	70773	9	SCR, 1/4-20 X 1 CARRIAGE SS		
15	86005630	57022	6	NUT, 3/8-16 HEX NYLOCK THIN SS		
16	86082880	66371	1	PLATE, AQ, ATTACH R 16 IN		
17	86228910	09139	6	BEARING, FLANGED .377 ID C .502 OD		
18	86276860	70747	6	SCR, 3/8-16 X 1.75 BSHCS SS		
19A	86001400	140527	1	BLADE, AQ RIGHT 16 INCH		
19B	86271840	730430	1	BLADE, AQ RT 16 INCH URETHANE		
20	86082380	57285	4	NUT, 5/16-18 HEX NYLOCK THIN SS		
21	86024970	66375	1	PLATE, AQ LOCK RIGHT 16 IN		
22	86024980	34393	1	FRAME, 36V SCRUB DECK		
23	86024960	47396	-	AQUA-MIZER 32IN SCRUBHEAD, LEFT		SERVICE ONLY
24	86004700	47401	-	AQUA-MIZER 32IN SCRUBHEAD, RIGHT		SERVICE ONLY

# SCRUB DECK MOTORS

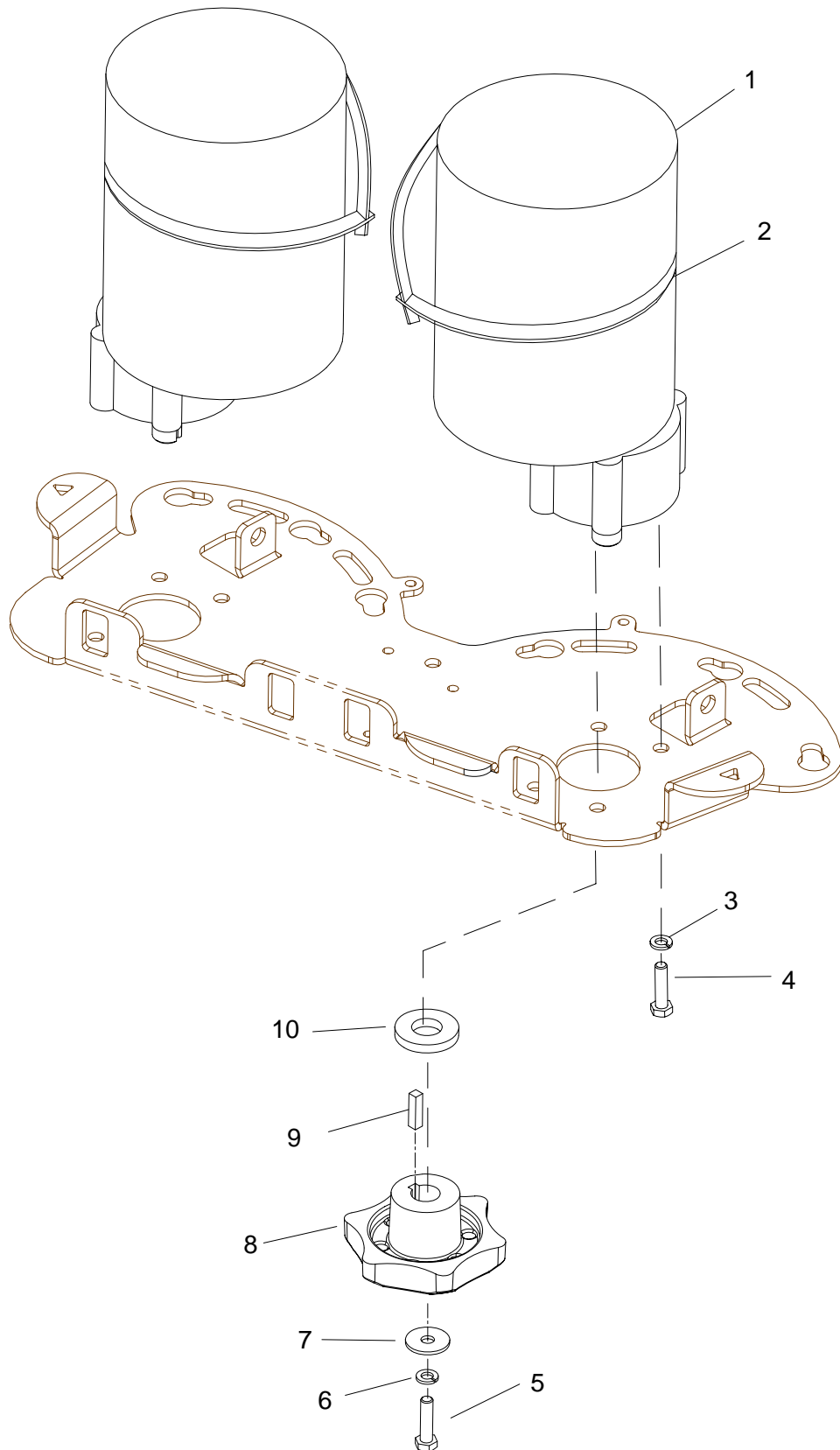

## SCRUB DECK MOTORS

REF	PART NO.	PRV NO.	QTY	DESCRIPTION	SERIAL NO. FROM	NOTES:
1	86005330	53632	2	MOTOR ASM, 24VDC 200RPM GEAR		
2	86002840	27196	2	CABLE TIE, .375 X 24.7		
3	86010790	87163	8	WASHER, 3/8 SPLIT LOCK PLTD		
4	86276970	70774	8	SCR, 3/8-16 X 3/4 HHCS SS		
5	86007020	70673	2	SCR, 5/16-18 X 1.25 HHCS SS		
6	86279130	87083	2	WASHER, 5/16 SPLIT LOCK PLTD		
7	86279630	87212	2	WASHER, .344ID X 1.13OD X .09T PLTD		
8	86003420	29220	2	DRIVER, BRUSH SD		
9	86004810	48040	2	KEY, 1/4 SQ. X 1.00		
10	86279640	87213	2	WASHER, .78ID X 1.63OD X .25T PLTD		

# SCRUB DECK SKIRT

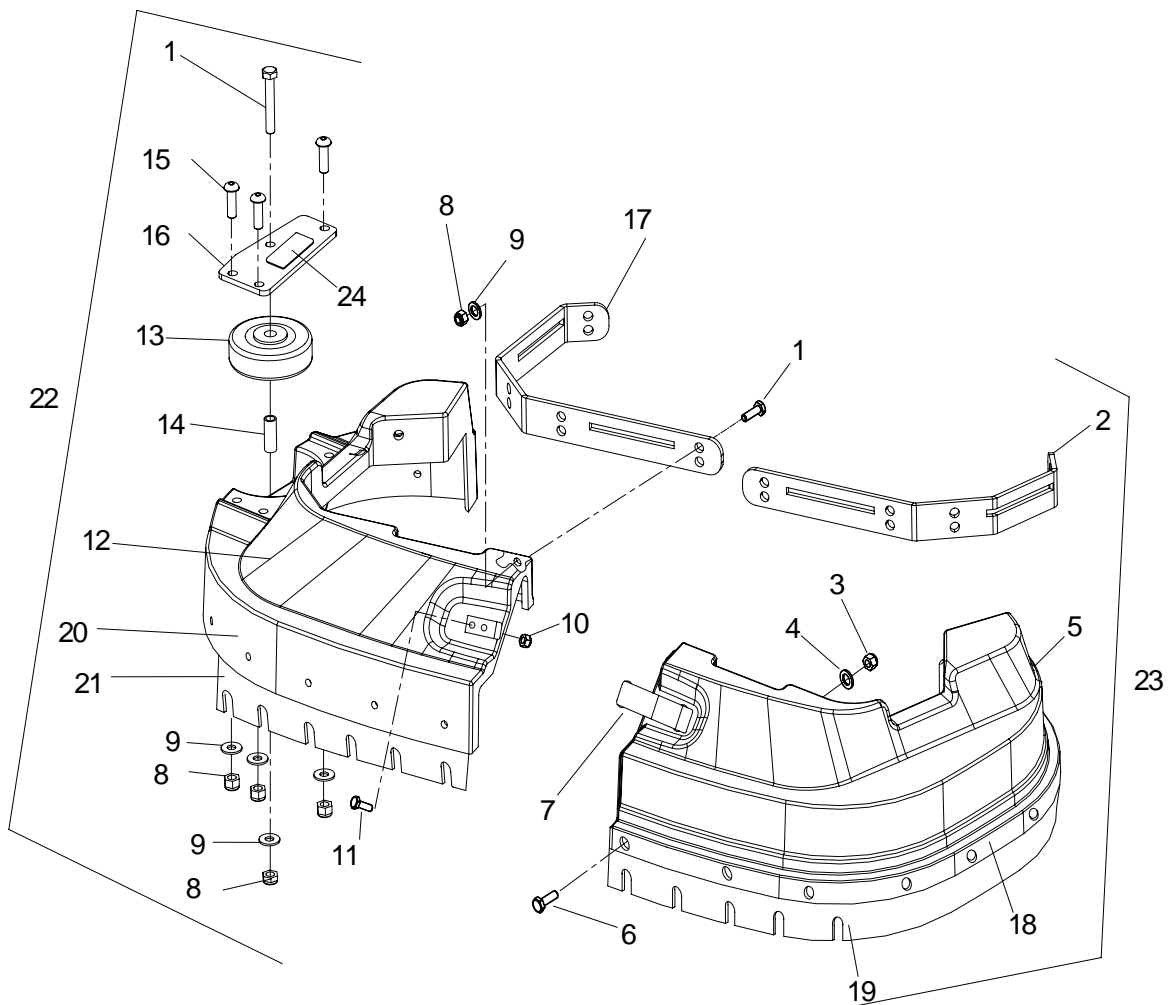

## SCRUB DECK SKIRT

REF	PART NO.	PRV NO.	QTY	DESCRIPTION	SERIAL NO. FROM	NOTES:
1	86006930	70514	11	SCR, 5/16-18 X 1.00 BSHCS SS		
2	86070050	140563	1	BRACKET, SHROUD RETAINER LEFT	1000094309	
3	86271900	57294	19	NUT, 10-24 HEX NYLOCK THIN SS		
4	86010650	87018	19	WASHER, #10 X 9/16 ODS		
5	86022470	730136	1	SHROUD, SCRUBDECK LEFT		
6	86277110	70789	19	SCR, 10-24 X 3/4 PPHMS SS	1000094309	
7	86161800	46-802531	1	LATCH & CONCEALED KEEPER		
8	86271840	57285	1	NUT, 5/16-18 HEX NYLOCK THIN SS	1000094309	
9	86292500	-	12	WASHER, 5/16 ID X 9/16 OD SS		
10	86270920	57049	4	NUT, 6-32 HEX NYLOCK SS		
11	86273950	70056	4	SCR, 6-32 X 1/2 PPHMS SS	1000094309	
12	86062970	730137	1	SHROUD, SCRUBDECK RIGHT		
13	86011020	89202	1	WHEEL, 3" DIA CUSHION RUBBER		
14	86001350	140390	1	BUSHING, SPANNER, .435 X 1.10		
15	86277150	70797	1	SCR, 5/16-18 X 2 BSHCS SS	1000094309	
16	86082950	66385	1	PLATE, BUMPER WHEEL ATTACH	1000094309	
17	86070040	140562	1	BRKT, SHROUD RETAINER RIGHT		
18	86066410	140549	1	BAND, SKIRT LEFT 32 INCH		
19	86007530	730145	1	SKIRT, 32 INCH LEFT		
20	86066400	140548	1	BAND, SKIRT RIGHT 32 INCH		
21	86007540	730146	1	SKIRT, 32 INCH RIGHT		
22	86004710	47412	-	SHROUD ASM, 32" RIGHT SCRUBHEAD		SERVICE ONLY
23	86004720	47413	-	SHROUD ASM, 32" LEFT SCRUBHEAD		SERVICE ONLY
24	86244100	500831	1	LABEL, AQUA-MIZER		

# SCRUB DECK LIFT LINKAGE

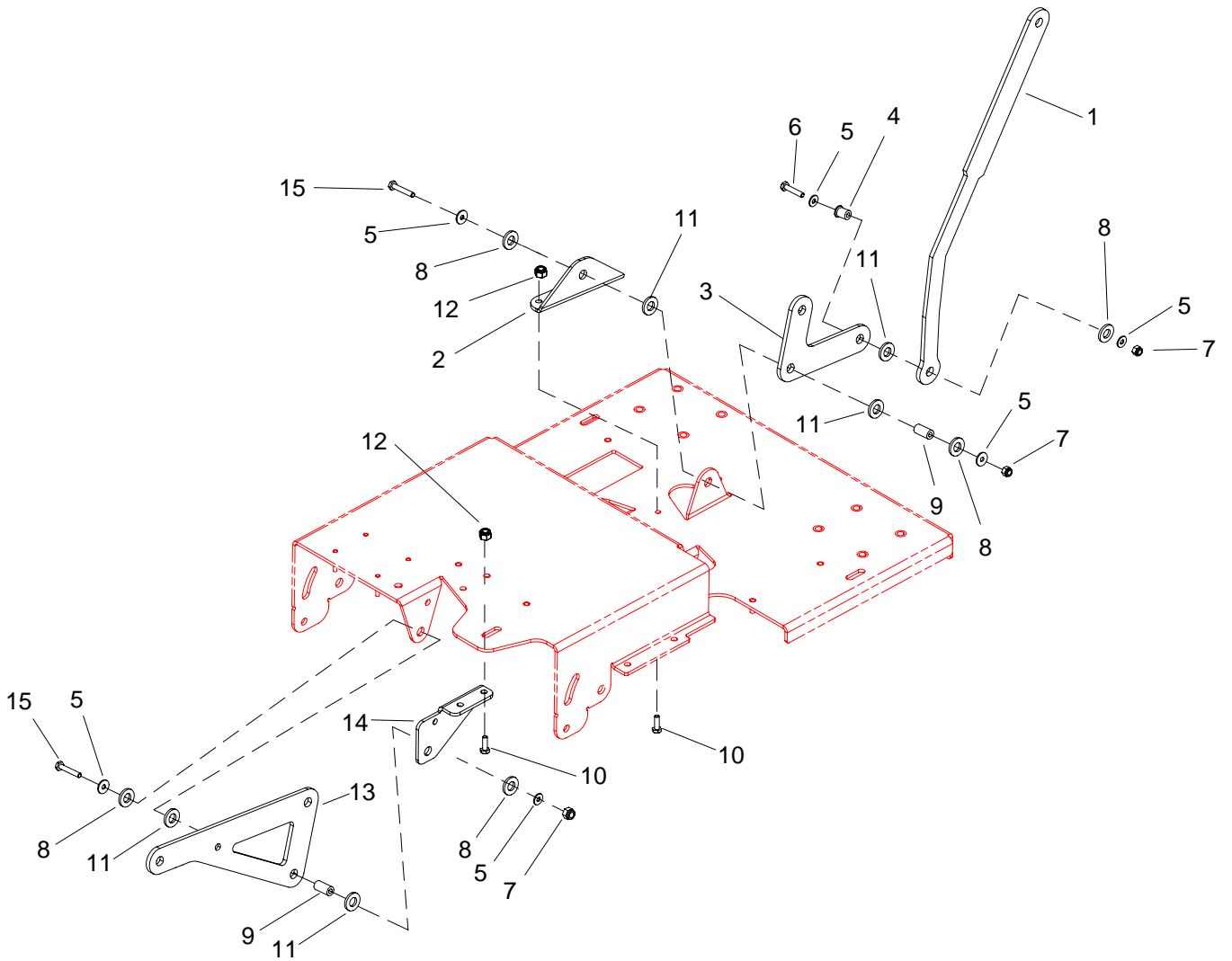

## SCRUB DECK LIFT LINKAGE

REF	PART NO.	PRV NO.	QTY	DESCRIPTION	SERIAL NO. FROM	NOTES:
1	86066820	140514	1	BAR, VERTICAL LINK		
2	86070000	140558	1	BRACKET, BELL CRANK SUPPORT REAR		
3	86066830	140515	1	BAR, DECK LINKAGE REAR		
4	86228900	09138	1	BEARING, FLANGED .252ID X .503OD		
5	86010630	87013	6	WASHER, 1/4ID X 5/8OD SS		
6	86069920	70019	1	SCR, 1/4-20 X 1.25 HHCS SS		
7	86271870	57290	3	NUT, 1/4-20 HEX NYLOCK THIN SS		
8	86259410	87206	5	WASHER, THRUST .51ID X 1OD X .063		
9	86228920	09140	2	BEARING, .252ID X .503OD X 1.0		
10	86276780	70728	4	SCR, 5/16-18 X 3/4 HHCS SS		
11	86271870	87205	5	WASHER, THRUST .51ID X 1OD BRO		
12	86271840	57285	4	NUT, 5/16-18 HEX NYLOCK THIN SS		
13	86066800	140512	1	BAR, LINKAGE, FRONT		
14	86070010	140559	1	BRACKET, FRAME MOUNT		
15	86273740	70010	2	SCR, 1/4-20 X 1.5 HHCS		

# SCRUB DECK LIFT LINKAGE

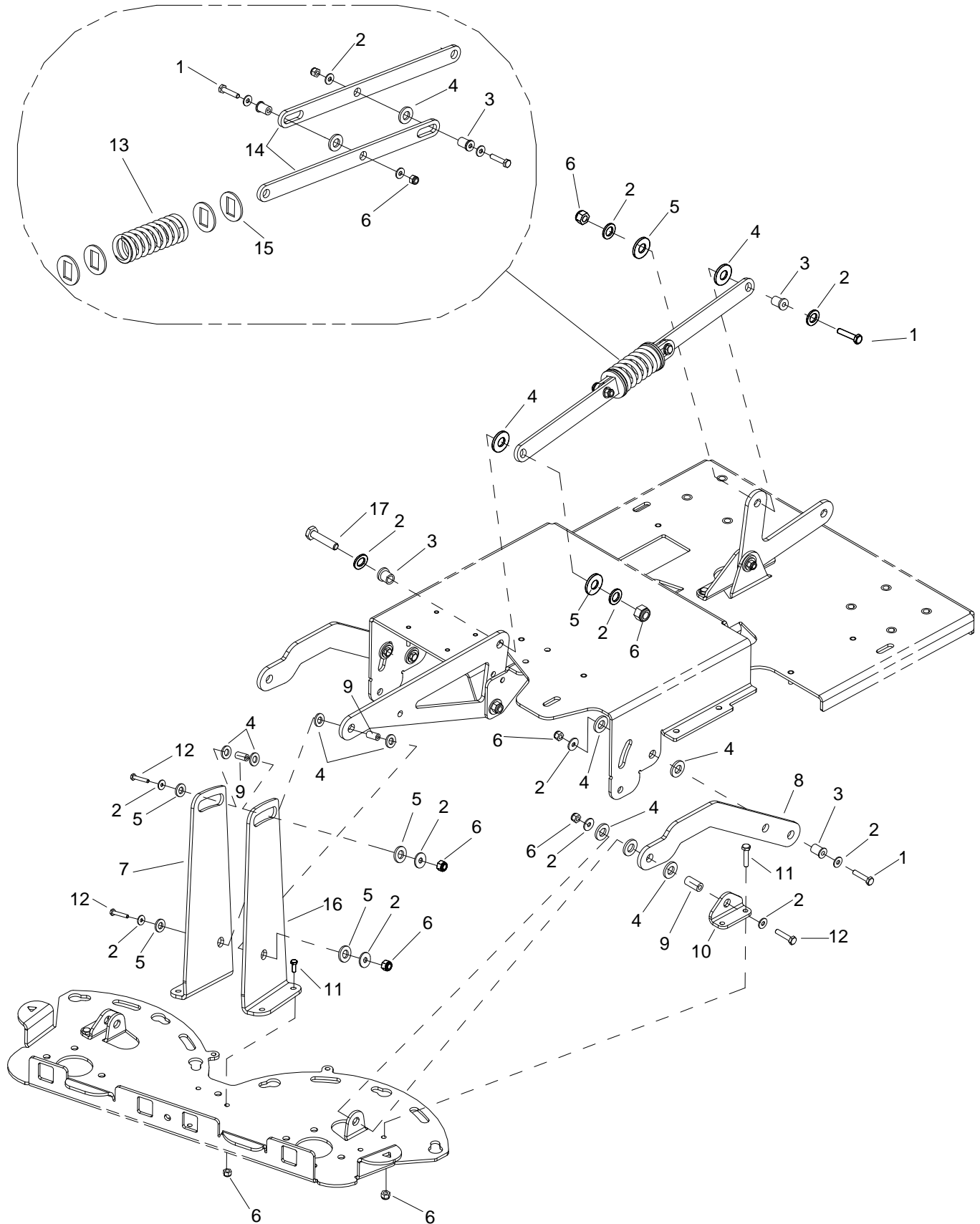

## SCRUB DECK LIFT LINKAGE

REF	PART NO.	PRV NO.	QTY	DESCRIPTION	SERIAL NO. FROM	NOTES:
1	86273820	70019	7	SCR, 1/4-20 X 1.25 HHCS		
2	86010630	87013	24	WASHER, 1/4 ID X 5/8 OD SS		
3	86228900	09138	8	BEARING FLANGED, .252 ID X .503 OD		
4	86259400	87205	20	WASHER, THRUST .51 ID X 1 OD BRO		
5	86259410	87206	6	WASHER, THRUST .51 ID X 1 OD X .063		
6	86271870	57290	18	NUT, 1/4-20 NYLOCK THIN SS		
7	86070200	140582	1	BRKT, SCRUB DECK LIFT, R.H.		
8	86066850	140519	2	BAR, LINKAGE		
9	86228920	09140	4	BEARING, .252 ID X .503 OD X 1.0		
10	86070030	140561	2	BRKT, ANGLE SUPPORT 36V		
11	86273780	70015	8	SCR, 1/4-20 X 3/4 HHCS SS NP		
12	86273740	70010	4	SCR, 1/4-20 X 1.5 HHCS		
13	86254880	730005	1	SPRING, COMP 1.687 OD X 4.5 L X .234 W		
14	86066760	140454	2	BAR, TENSIONER		
15	86090270	87204	4	WASHER, RECTANGULAR HOLE		
16	86070210	140583	1	BRKT, SCRUB DECK LIFT, L.H.		
17	86276610	70697	1	SCR, 1/4-20 X 1.25 PPHMS		

# SOLUTION

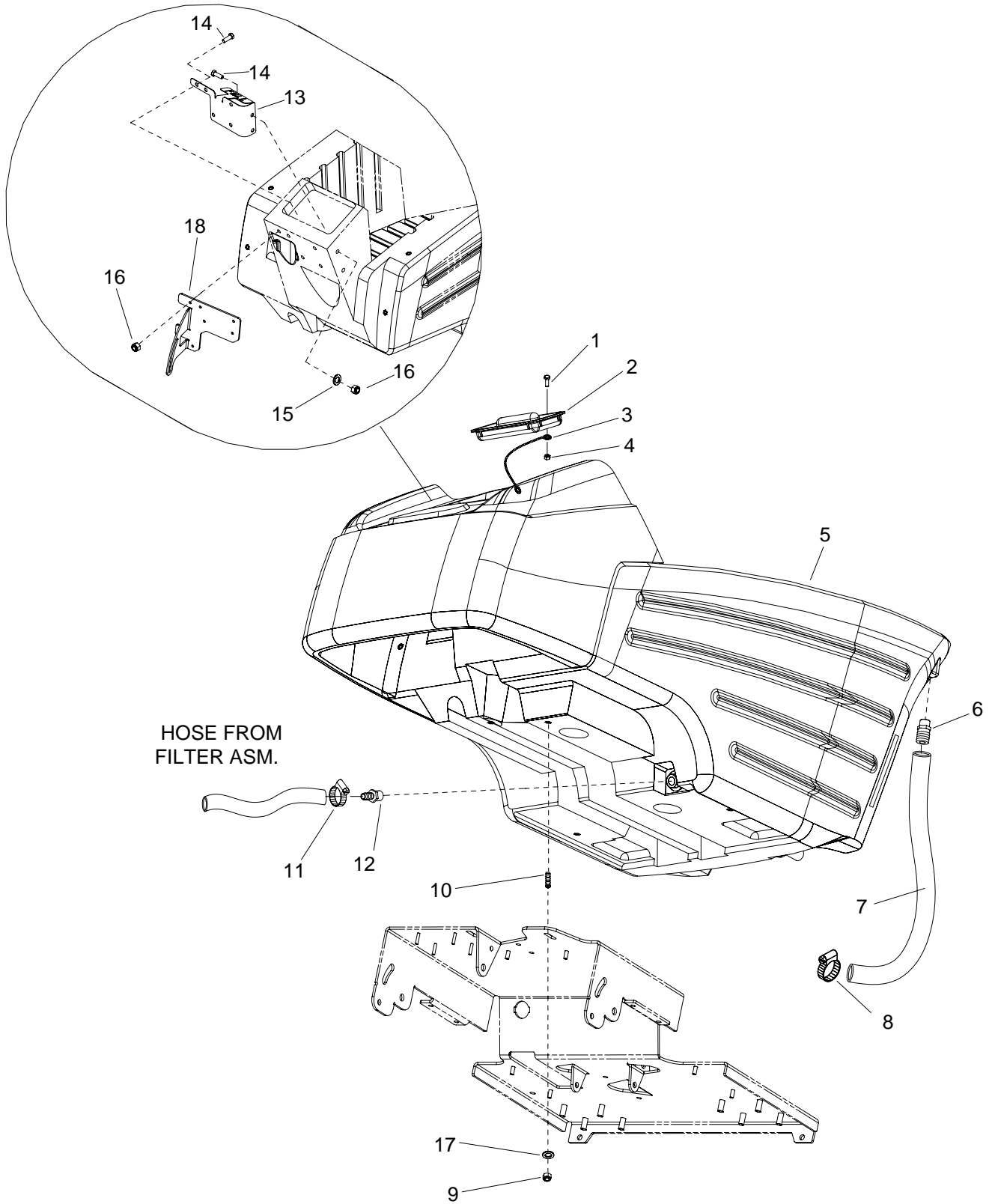

**SOLUTION**

REF	PART NO.	PRV NO.	QTY	DESCRIPTION	SERIAL NO. FROM	NOTES:
1	86273950	70056	1	SCR, 6-32 X 1/2 PPHMS		
2	86234790	27827	1	COVER, SOLUTION TANK		
3	86246080	51368	1	LANYARD, 18.0 W/ LOOP & EYE		
4	86014810	-	1	NUT, 6-32 ACORN SS		
5	86032550	75372	1	TANK, SOLUTION 36V		
6	86240460	40089	1	HOSEBARB, 1/2 MPT X 1		
7	86282050	39562	1	HOSE, 1.0ID 1/8W X 26 CLR		
8	86233110	20018	1	CLAMP, 1.0" WORM GEAR		
9	86271840	57285	4	NUT, 5/16-18 HEX NYLOCK THIN SS		
10	86276380	70639	4	SCR, 5/16 X 1.75 SSSCU		
11	86233150	20042	1	CLAMP, 3/8 HOSE (D-SLOT)		
12	86197910	40022	1	HOSEBARB, 1/2 MPT X 1/2 POLY DL		
13	86070090	140568	1	BRKT, SOLUTION FILL 36V		
14	86276930	70755	7	SCR, 3/8-16 X 1 HHCS SS NP		
15	86279590	87185	2	WASHER, 3/8 SEALING X 3/4 OD		WAS 87003
16	86005630	57022	7	NUT, 3/8-16 HEX NYLOCK THIN SS		
17	86010670	87029	4	WASHER,5/16 FLAT SS		
18	86070190	140581	1	BRKT, SCRUB DECK GUIDE 36V		

# SOLUTION

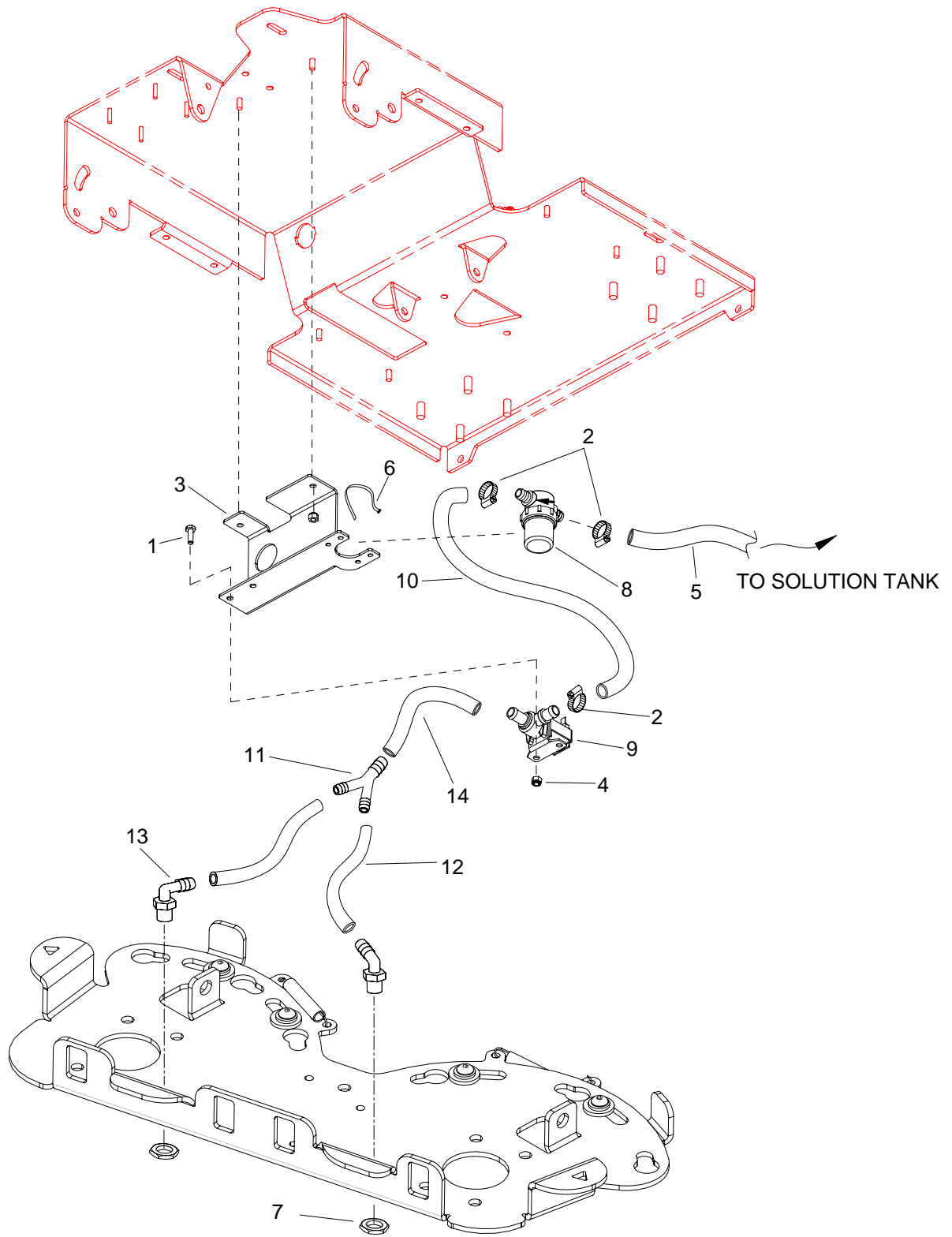

**SOLUTION**

REF	PART NO.	PRV NO.	QTY	DESCRIPTION	SERIAL NO. FROM	NOTES:
1	86273750	70011	2	SCR, 1/4-20 X 5/8 HHCS SS NP		
2	86233150	20042	3	CLAMP, 3/8 HOSE (D-SLOT)		
3	86070020	140560	1	BRACKET, FILTER/SOLUTION MOUNT		
4	86271870	57290	4	NUT, 1/4-20 HEX NYLOCK THIN SS		
5	86282190	39616	1	HOSE, 1/2" WIRE BOUND X 13"		
6	86264940	27051	2	CABLE TIE, 11.38" UL/CSA		
7	86271690	57238	2	NUT, 3/8 NPT PLASTIC		
8	86007560	730161	1	STRAINER, 1/2 HOSE 20 MESH		
-	86005870	59021	-	O-RING, FILTER SEAL RON-VIK		SERVICE ONLY
-	86007750	73405	-	SCREEN, 20 MESH STRAINER		SERVICE ONLY
-	86002860	27372	-	CAP, STRAINER 26/32		SERVICE ONLY
9	86009710	82312	1	VALVE, 36VDC SOL 1/2" HOSEBARB		
-	86003460	29260	-	DIAPHRAGM, SRVC PART SLND		SERVICE ONLY
-	86136820	47395	-	SOLENOID SPRING KIT		SERVICE ONLY
10	86281100	39274	1	HOSE, 1/2 WIRE BOUND X 7"		
11	86003580	34327	1	FITTING, 1/2" X 3/8" X 3/8" RED.		
12	86280820	39035	2	HOSE, NYLOBRAID X 10"		
13	86001550	40043	2	HOSEBARB, 3/8 MPT X 3/8 90D		
14	86240280	39711	1	HOSE, 1/2ID WIRE BOUND X 8"		

# SQUEEGEE

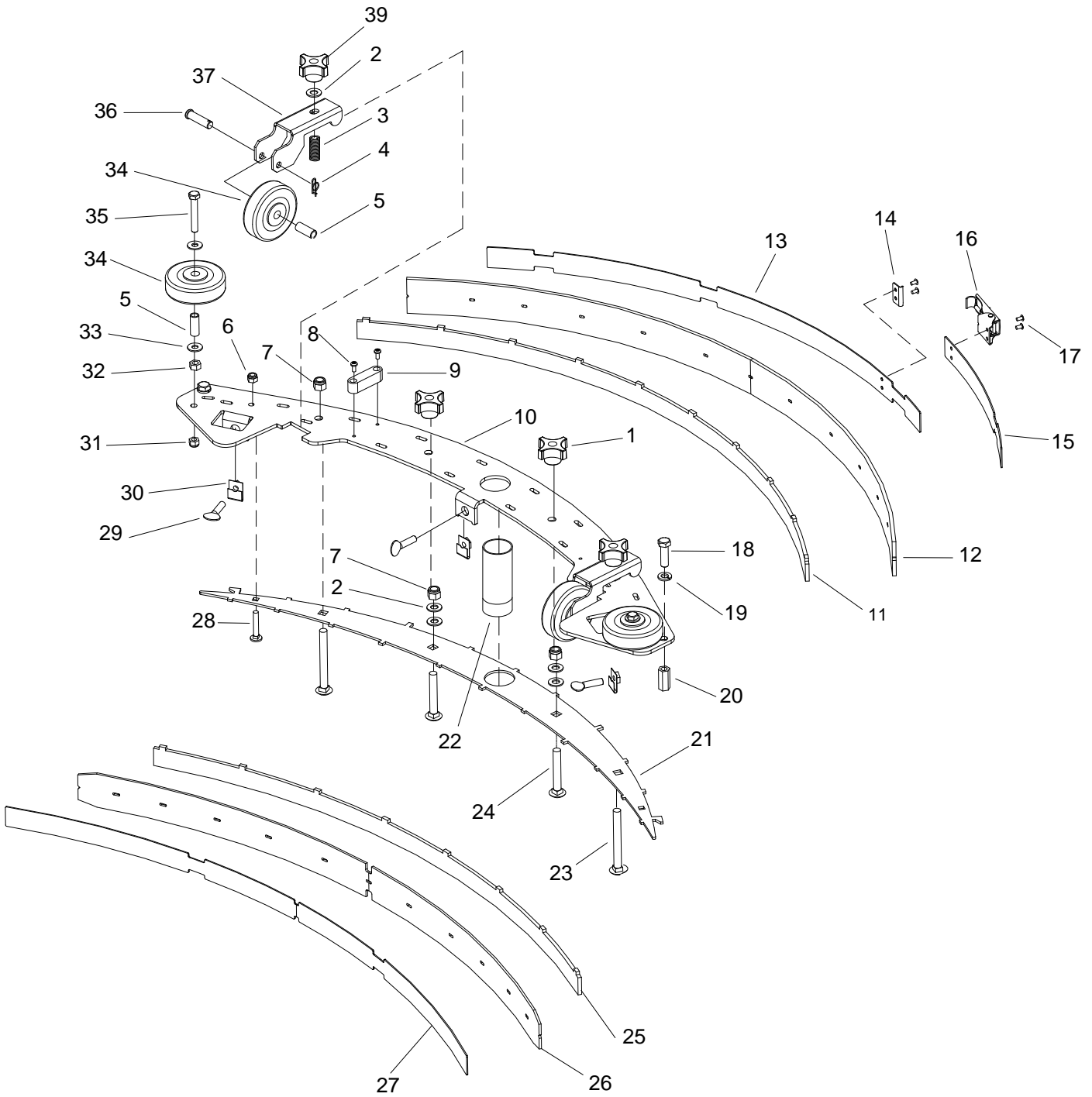

# SQUEEGEE

REF	PART NO.	PRV NO.	QTY	DESCRIPTION	SERIAL NO. FROM	NOTES:
1	86009200	81535	2	KNOB, 3/8-16 4 PRONG	1000099023	WAS 4
2	86010680	87030	6	WASHER, 3/8 X 3/4 NYLON		
3	86007780	73576	2	SPRING, COMP .60D X 2.0L X .045W		
4	86008660	80605	2	COTTER, 5/16 RING		
5	86001350	140390	4	BUSHING, SPANNER .435 X 1.10		
6	86271870	57290	2	NUT, 1/4-20 HEX NYLOCK THIN SS		
7	86005630	57022	4	NUT, 3/8-16 HEX NYLOCK THIN SS		
8	86274130	70098	2	SCR, 8-32 X 3/8 PHTC 'F' PLTD		
9	86009910	82576	1	VIAL, LEVEL		
10	86082460	62974	1	PLATE, SQUEEGEE TOP 40"		
11	86082480	62976	1	PLATE, SQG REAR 40"		
12A	86007490	730133	1	SQUEEGEE, REAR BLADE LINATEX		
12B	86137040	730425	1	SQUEEGEE, REAR BLADE URETHANE		
13	86066360	140381	1	BAND, REAR SQUEEGEE		
14	86009180	81489	1	STRIKER, SQUEEGEE STRAP REAR		
15	86001330	140382	1	BAND, REAR SQUEEGEE		
16	86009170	81488	1	LATCH, SQUEEGEE STRAP		
17	86006400	67380	4	RIVET, 5/32OD X 1/8 GRIP		
18	86276920	70755	2	SCR, 3/8-16 X 1 HHCS SS NP		
19	86010790	87163	2	WASHER, 3/8 SPLIT		
20	86005840	57269	2	NUT, 3/8-16 HEX COUPLING SS		
21	86082490	62977	1	PLATE, SQUEEGEE BOTTOM 40"		
22	86008390	78493	1	TUBE ASM, SQUEEGEE VAC		
23	86276990	70776	2	SCR, 3/8-16 X 3.5 CARRIAGE SS		
24	86276870	70748	2	SCR, 3/8-16 X 2.5 CARRIAGE SS		
25	86082470	62975	1	PLATE, SQUEEGEE FRONT 40" SPACER		
26A	86009830	82528	1	BLADE, SQUEEGEE FRONT LINATEX		
26B	86137050	730426	1	BLADE, SQUEEGEE FRONT URETHANE		
27	86066350	140380	1	STRAP, SQUEEGEE		
28	86277000	70777	2	SCR, 1/4-20 X 1.75 CARRIAGE SS		
29	86007040	70680	3	SCR, 5/16-18 X 1 THUMB SS TYPE P		
30	86271820	57270	3	NUT, 5/16-18 CAPTIVE "J" PLTD		
31	86271840	57285	2	NUT, 5/16-18 HEX NYLOCK THIN SS		
32	86005650	57031	2	NUT, 5/16-18 HEX		
33	86010670	87029	4	WASHER, 5/16 X 3/4 SS		
34	86011020	89202	4	WHEEL, 3" DIA. CUSHION RUBBER		
35	86276980	70775	2	SCR, 5/16-18 X 2.00 HHCS SS		
36	86006270	66276	2	PIN, CLEVIS 5/16 X 1.63		
37	86069870	140531	2	BRACKET, SQUEEGEE WHEEL		
38	86026530	47399	-	SQUEEGEE ASM 32IN SCRUBHEAD		SERVICE ASM
39	86004890	48095	2	KNOB, ALUM 3/8-16 NYLOCK NUT SS	1000099023	

# SQUEEGEE LIFT LINKAGE (LOWER)

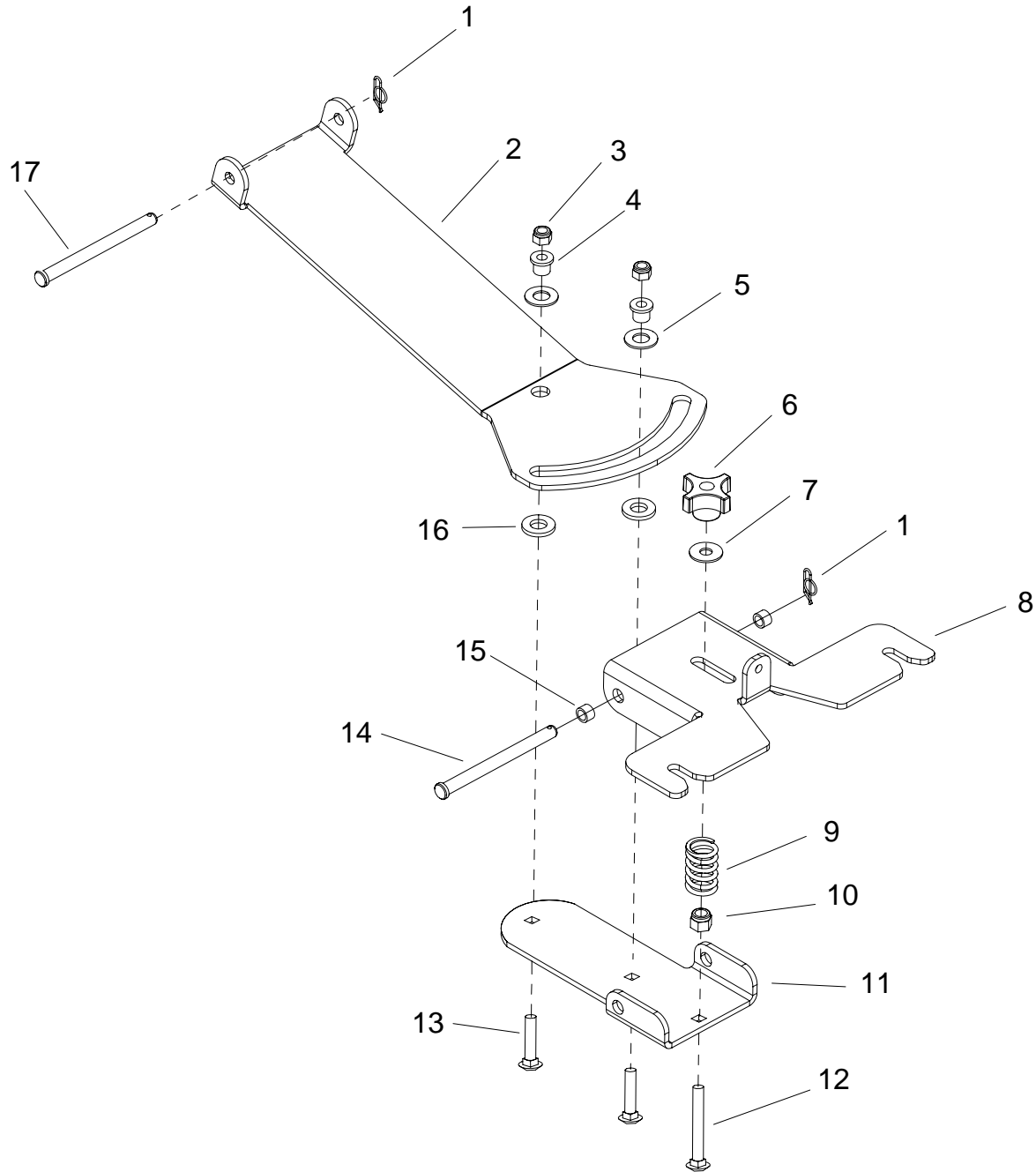

## SQUEEGEE LIFT LINKAGE (LOWER)

REF	PART NO.	PRV NO.	QTY	DESCRIPTION	SERIAL NO. FROM	NOTES:
1	86008670	80606	2	COTTER, 3/8" RING		
2	86069450	140455	1	BRACKET, SQG PIVOT LIFT		
3	86271840	57285	2	NUT, 5/16-18 HEX NYLOCK THIN SS		
4	86228840	09124	2	BEARING, FLANGED .314ID X .502OD		
5	86259410	87206	2	WASHER, THRUST .51ID X 1OD X .063		
6	86009200	81535	1	KNOB, 3/8-16 4 PRONG ALUM		
7	86279510	87171	1	WASHER, 3/8 FLAT		
8	86082150	62922	1	PLATE, SQUEEGEE MOUNT		
9	86007270	730006	1	SPRING, COMP 1.10OD X 2.0L X .148W		
10	86005630	57022	1	NUT, 3/8-16 HEX NYLOCK THIN SS		
11	86072530	14409	1	BRACKET, CAMBER PIVOT		
12	86276870	70748	1	SCR, 3/8-16 X 2.50 CARRIAGE SS		
13	86277130	70795	2	SCR, 5-16-18 X 1.00 CARRIAGE SS		
14	86249060	82061	1	PIN, CLEVIS 3/8 X 4.63 PLTD		
15	86008870	80815	2	BEARING, FLANGED 3/8" ID X 11/16"		
16	86259400	87205	2	WASHER, THRUST .51ID X 1OD BRO		
17	86008860	80808	1	PIN, CLEVIS 3/8" X 5.5"L PLTD		

# VACUUM

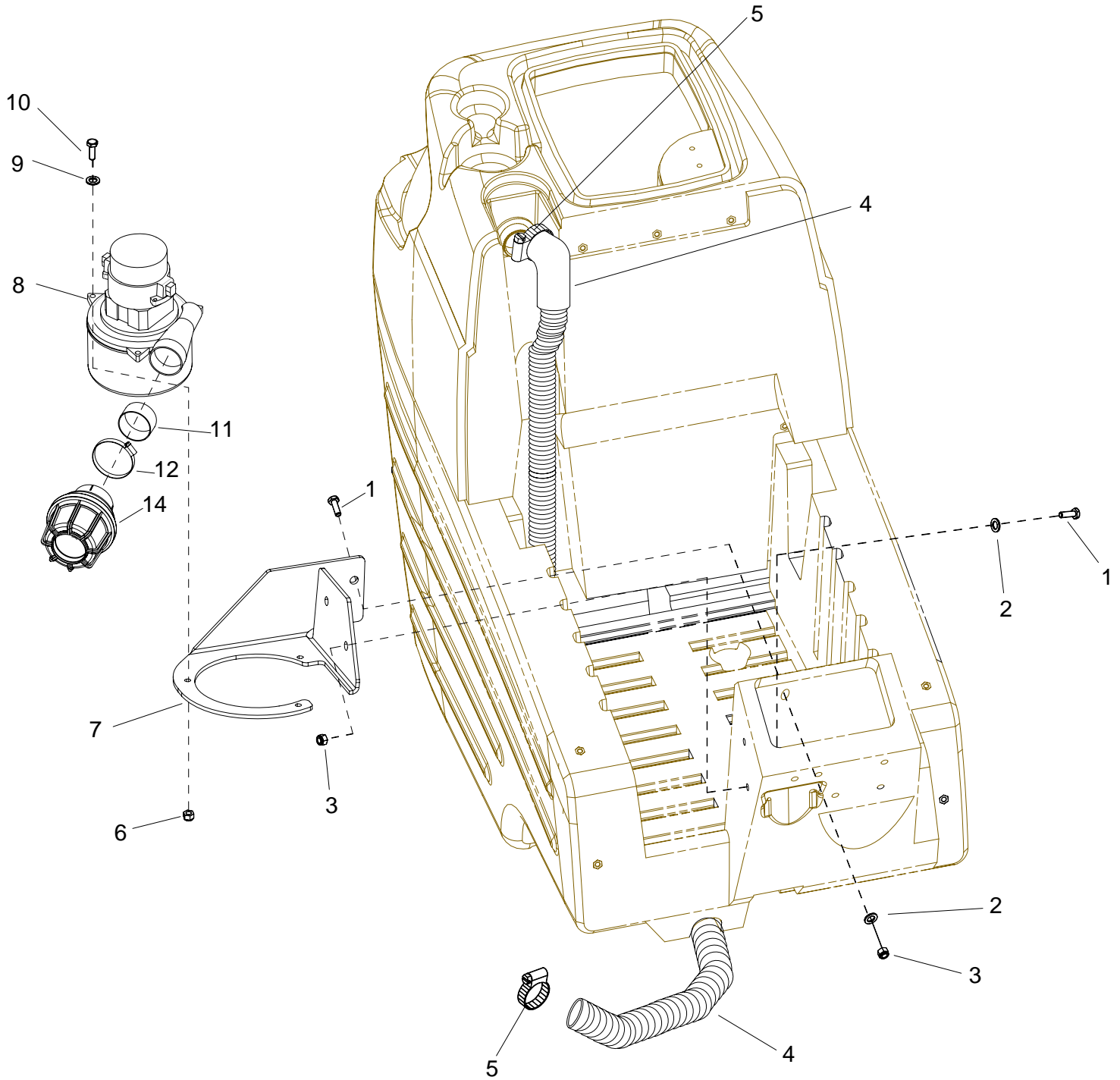

**VACUUM**

REF	PART NO.	PRV NO.	QTY	DESCRIPTION	SERIAL NO. FROM	NOTES:
1	86276920	70755	3	SCR, 3/8-16 X25 HHCS SS NP		
2	86278910	87003	3	WASHER, 3/8ID X 7/8OD SS		
3	86005630	57022	3	NUT, 3/8-16 HEX NYLOCK THIN SS		
4	86001620	40087	1	HOSE ASM, 1.5 BLK VAC X 67		
5	86002400	20064	2	CLAMP, 2.0" WORM GEAR X .312W		
6	86271870	57290	3	NUT, 1/4-20 HEX NYLOCK THIN SS		
7	86069820	140523	1	BRACKET, VACUUM MOUNT		
8	86005450	53799	1	VAC MOTOR ASM, 36VDC 3 STAGE		
-	86230800	140550	-	BRUSH SET, 24V 3ST VAC AMETEK		SERVICE ONLY
-	86135310	140686	-	BRUSH SET, 24V/36V VAC WINDSOR	1000122411	SERVICE ONLY
9	86010630	87013	3	WASHER, 1/4ID X 5/8OD SS		
10	86273810	70018	3	SCR, 1/4-20 X 1 HHCS SS		
11	86091170	730174	1	TUBE, 2.0 OD X .05W X 1.0L		
12	86233430	81431	1	CLAMP, 2.50 WORM GEAR		
13	-	OPEN	-	-		
14	86064910	54194	1	MUFFLER, VAC MOTOR	1000122451	

# WHEELS & FRAME

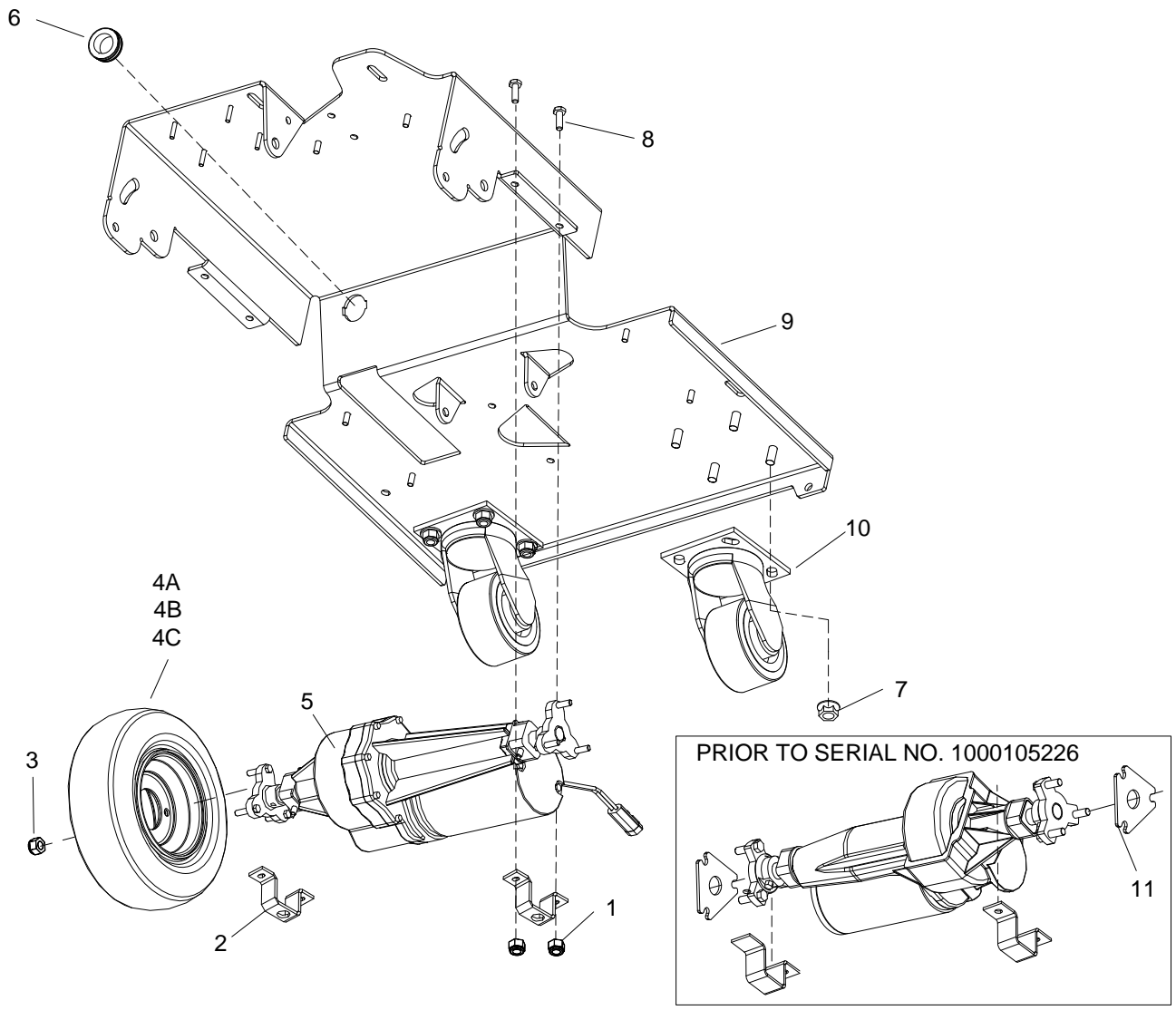

## WHEELS & FRAME

REF	PART NO.	PRV NO.	QTY	DESCRIPTION	SERIAL NO. FROM	NOTES:
1	86271840	57285	4	NUT, 5/16-18 HEX NYLOCK THIN SS		
2	86215770	140532	2	BRACKET, TRANSAXLE MOUNT		
3	86010090	82738	6	NUT, 7/16-20 WHEEL PLTD		
4A	86090640	830732	2	WHEEL ASM, 12" FMFL N-MARKING		OPTIONAL (STANDARD ON BSCSC326)
4B	86137410	830690	-	WHEEL ASM, 12" SOLID SCBR CMPD		OPTIONAL
4C	86010370	830756	2	WHEEL ASM, 12" FMFL BLK KNOBBY		
5	86000770	05121	1	AXLE MOTOR DRIVE, 36VDC		
-	86001360	140394	-	BRUSH SET, CCL MOTORS		SERVICE ONLY
-	86135870	47370	-	HUB KIT, TRANSAXLE 05121		SERVICE ONLY
6	86238430	36191	1	GROMMET, 1.00ID 3/16 GRIP		
7	86270880	57032	8	NUT, 3/8-16 SERRATED FLG		
8	86006560	70083	4	SCR, 5/16-18 X 1 HHCS SS NP		
9	86236660	34392	1	FRAME, MAIN 36V		
10	86002310	18041	2	CASTER, 4 DIA X 2 W X 3.56R		
11	86087270	730172	2	SPACER, TRANSAXLE 36V	1000105226	SERVICE ONLY

# WIRING- BATTERY

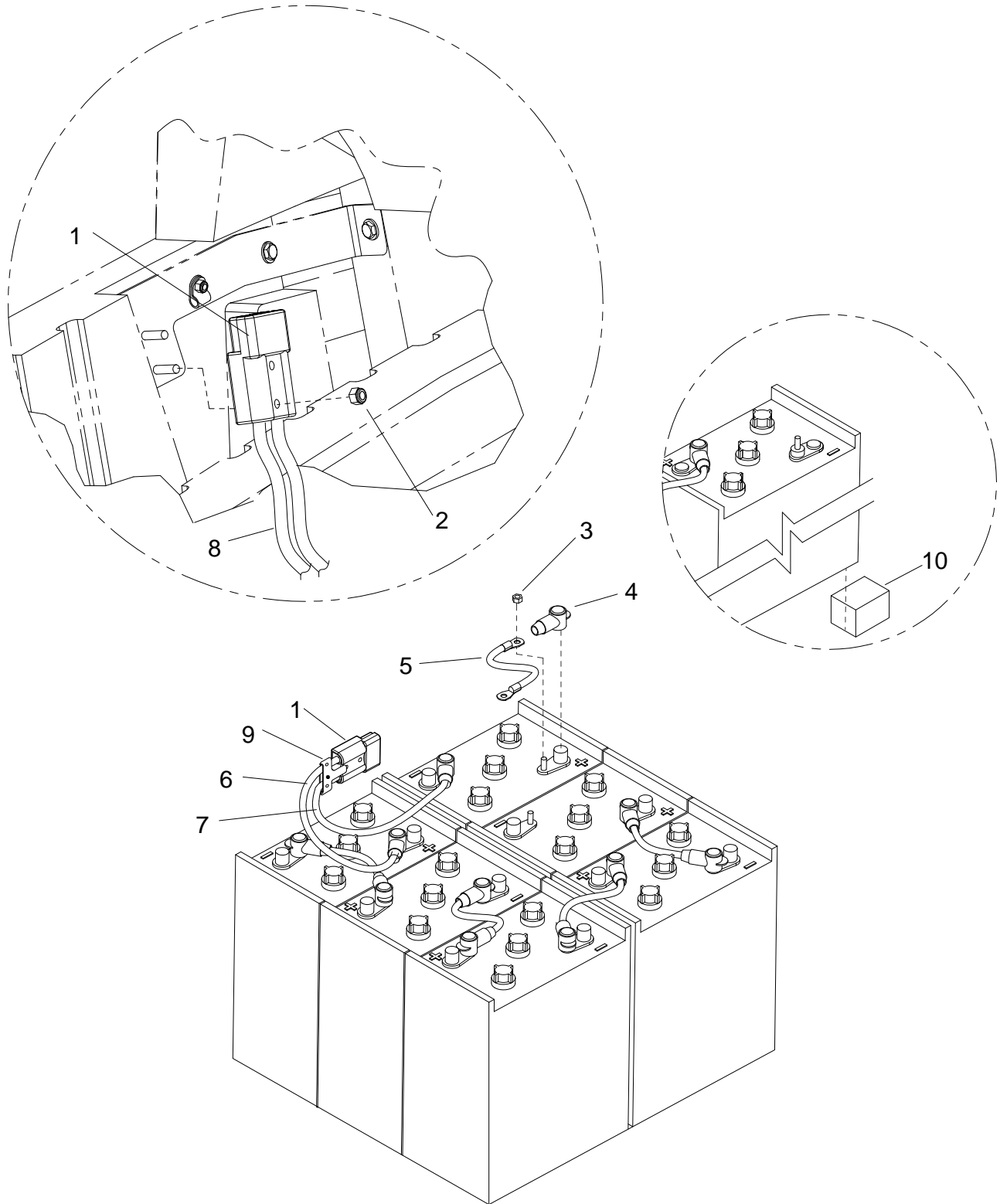

**WIRING-BATTERY**

REF	PART NO.	PRV NO.	QTY	DESCRIPTION	SERIAL NO. FROM	NOTES:
1	86008760	80682	1	CONNECTOR, BATTERY GRY, 175AMP		
2	86271870	57290	2	NUT, 1/4-20 HEX NYLOCK THIN SS		
3	86271910	57295	12	NUT, 5/16-18 FLEXLOCK		
4	86009000	80889	12	BOOT, RUBBER TERM. ISOLATOR		
5	86009000	81131	5	WIRE, 4 X 9.5 BK 5/16 RING X 5/16 RING		
6	86008920	880352	1	WIRE, 4X20 RD C, TERM X 5/16 RING		
7	86010860	880353	1	WIRE, 4X20 BK C, TERM X 5/16 RING		
8	86260520	880384	2	WIRE, 4X67 BK C. TERM 5/16 RING		
9	86233360	28038	1	CLAMP, CABLE KIT SY945		
10	86312710	-	2	BLOCK, 3.5 X 4 X 5		FOR 86312720 BATTERIES

# WIRING GROUP – CONTROL PANEL

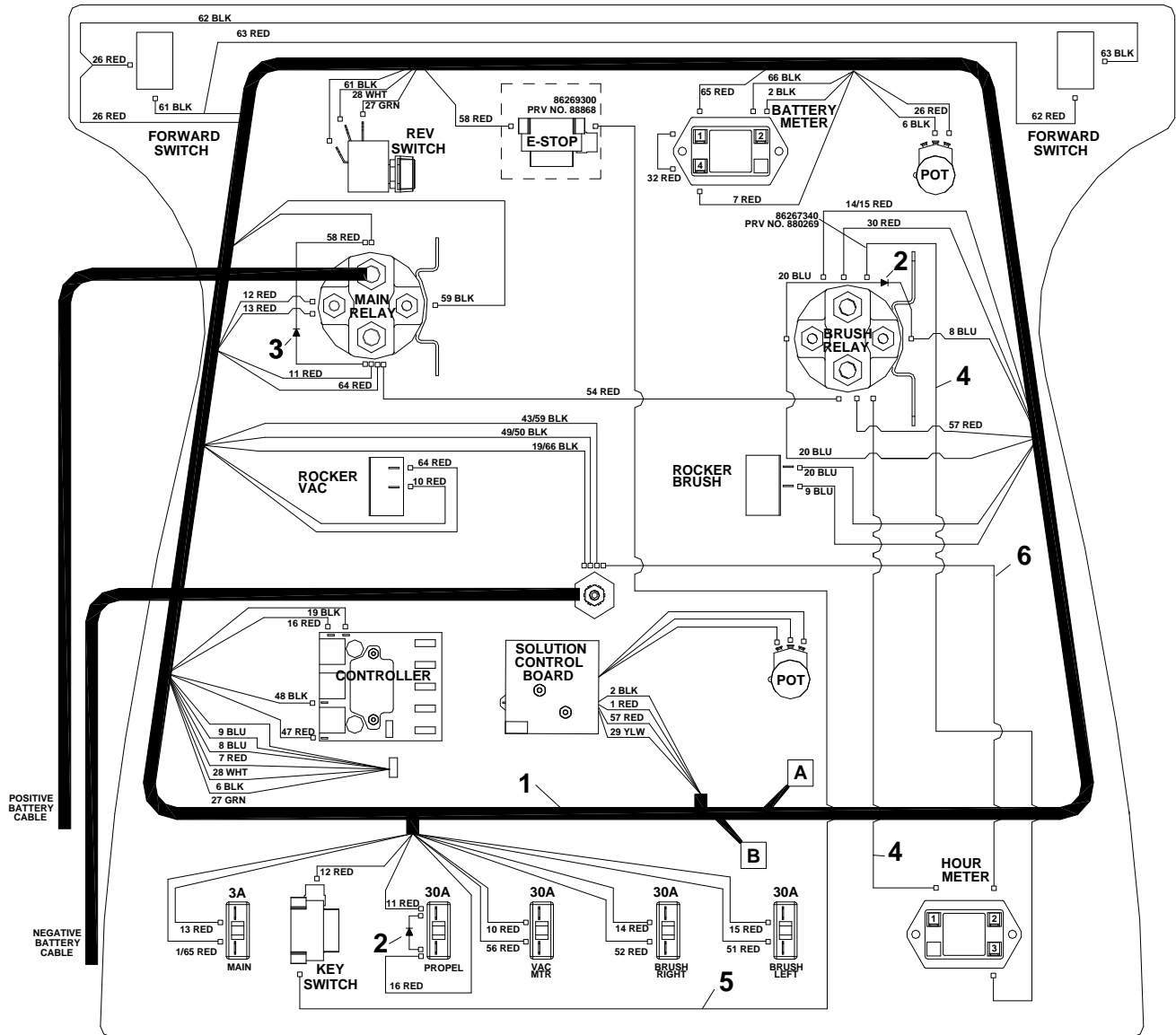
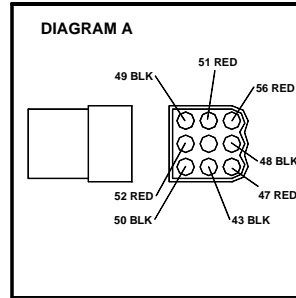
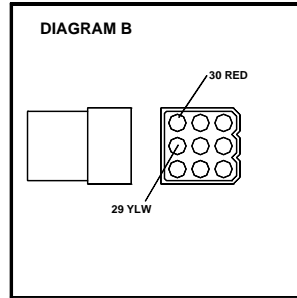

INDICATES OPTIONAL ACCESSORY.

## **WIRING GROUP – CONTROL PANEL**

REF	PART NO.	PRV NO.	QTY	DESCRIPTION	SERIAL NO. FROM	NOTES:
1	86239000	41443	1	HARNESS, PANEL BASIC		
2	86261210	29204	2	DIODE ASM, 76008 X 76008		
3	86003410	29215	1	DIODE ASM, 76075 X 76075		
4	86267340	880269	2	WIRE, 22" RED/18 76040 X 76075		
5	86269300	88868	1	WIRE, 16" RED/18 STRIP X STRIP		
6	86267360	880271	1	WIRE, 14" BLK/18 76011 X 76040		

# WIRING GROUP – MAIN HARNESS

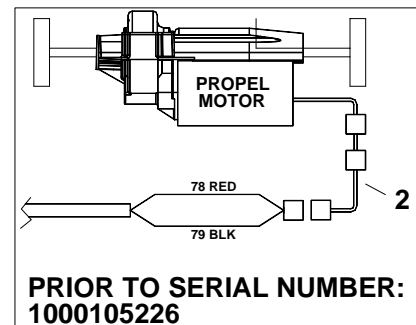
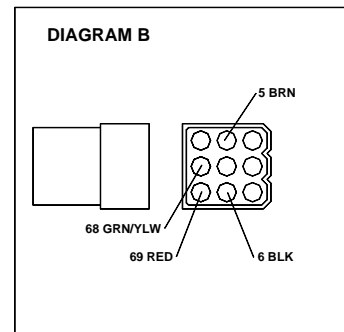
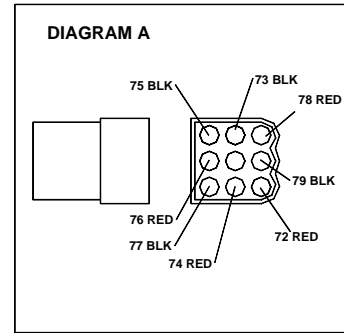
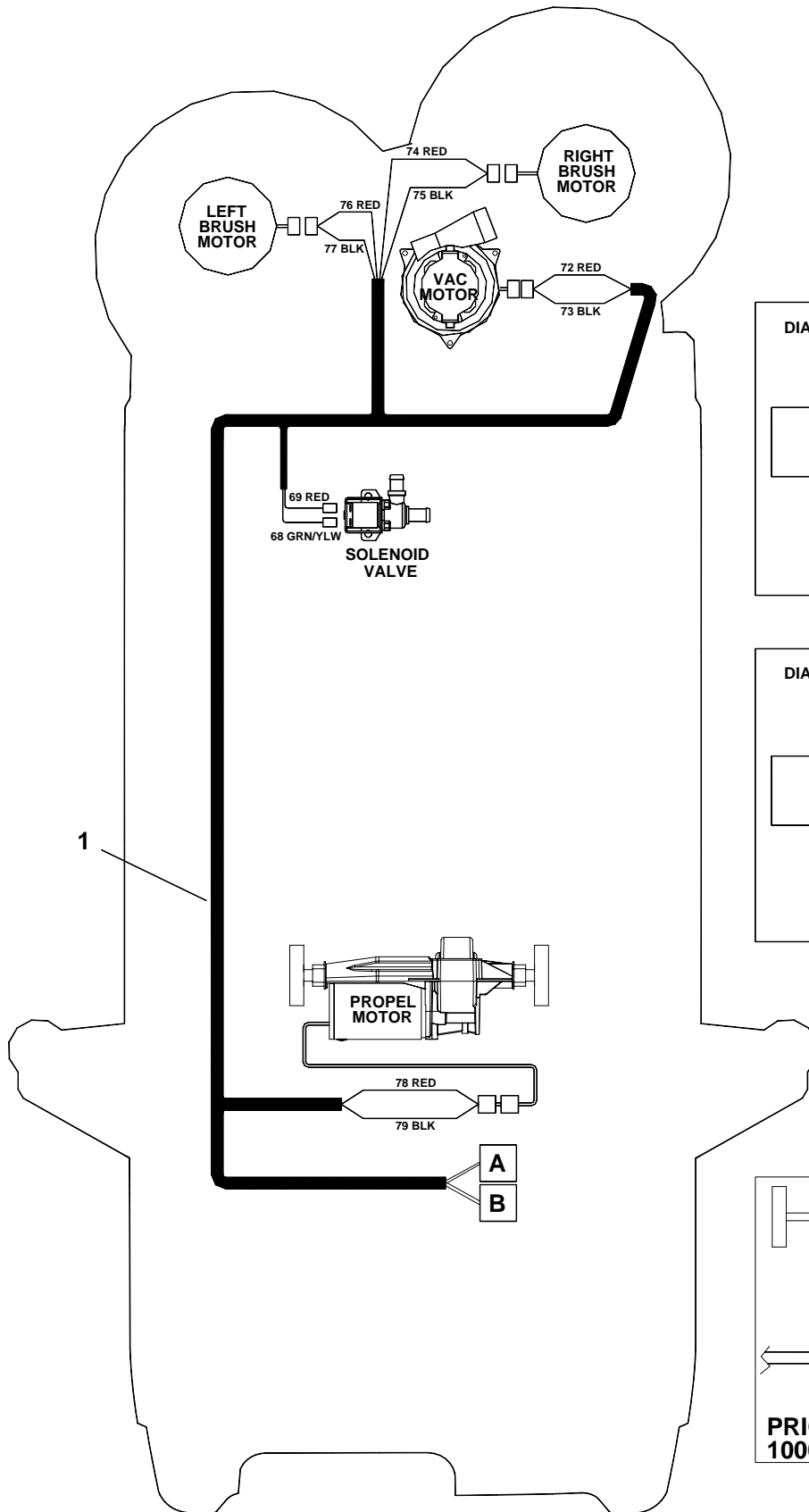

## **WIRING GROUP – MAIN HARNESS**

REF	PART NO.	PRV NO.	QTY	DESCRIPTION	SERIAL NO. FROM	NOTES:
1	86238980	41441	1	HARNESS, MAIN		
2	86260400	880212	1	WIRE ASM, REV POALRITY JUMPER		SERVICE ONLY

# WIRING GROUP – SCHEMATIC-SC326

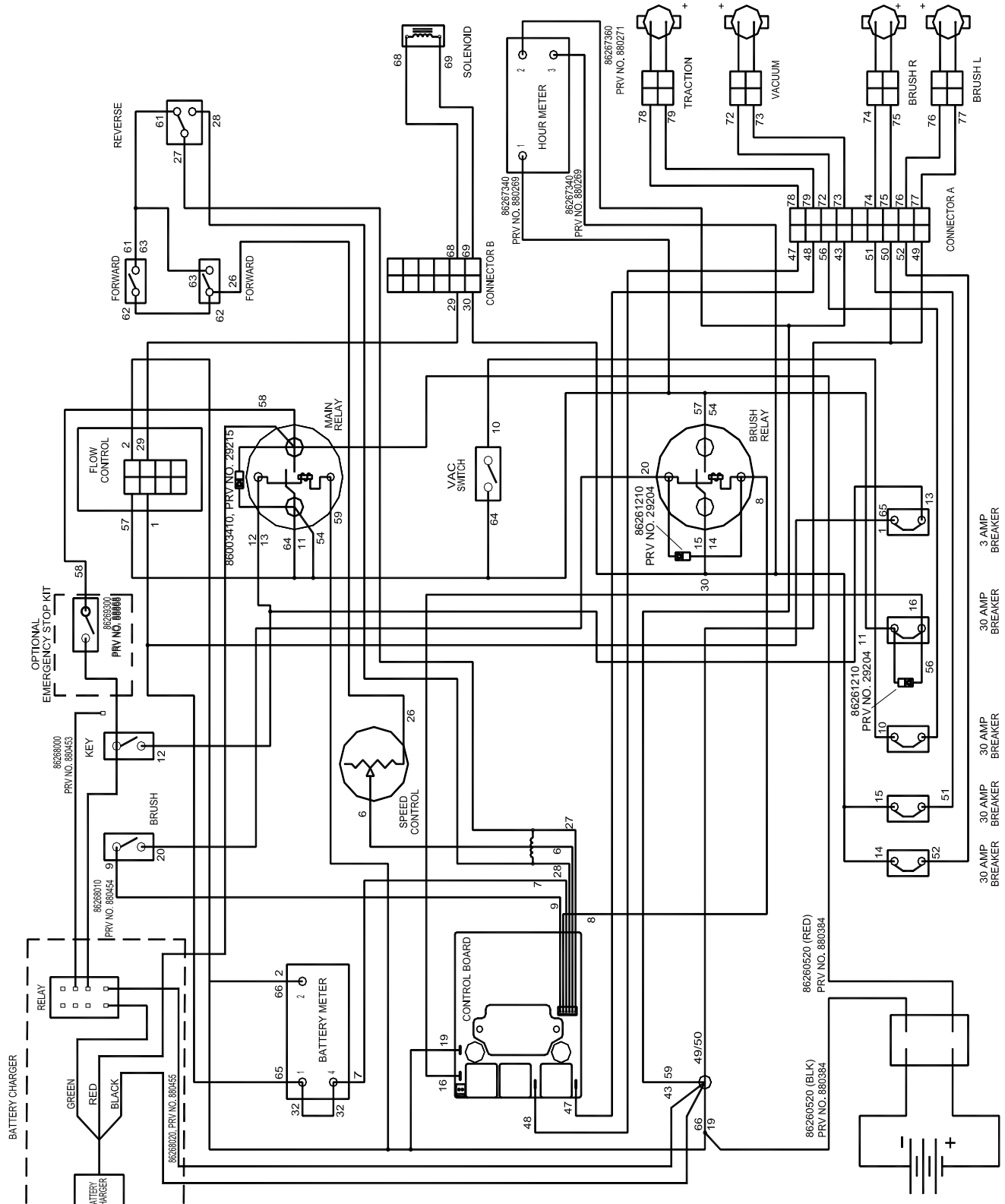

INDICATES OPTIONAL ACCESSORY

# WIRING GROUP – SCHEMATIC-SCC326

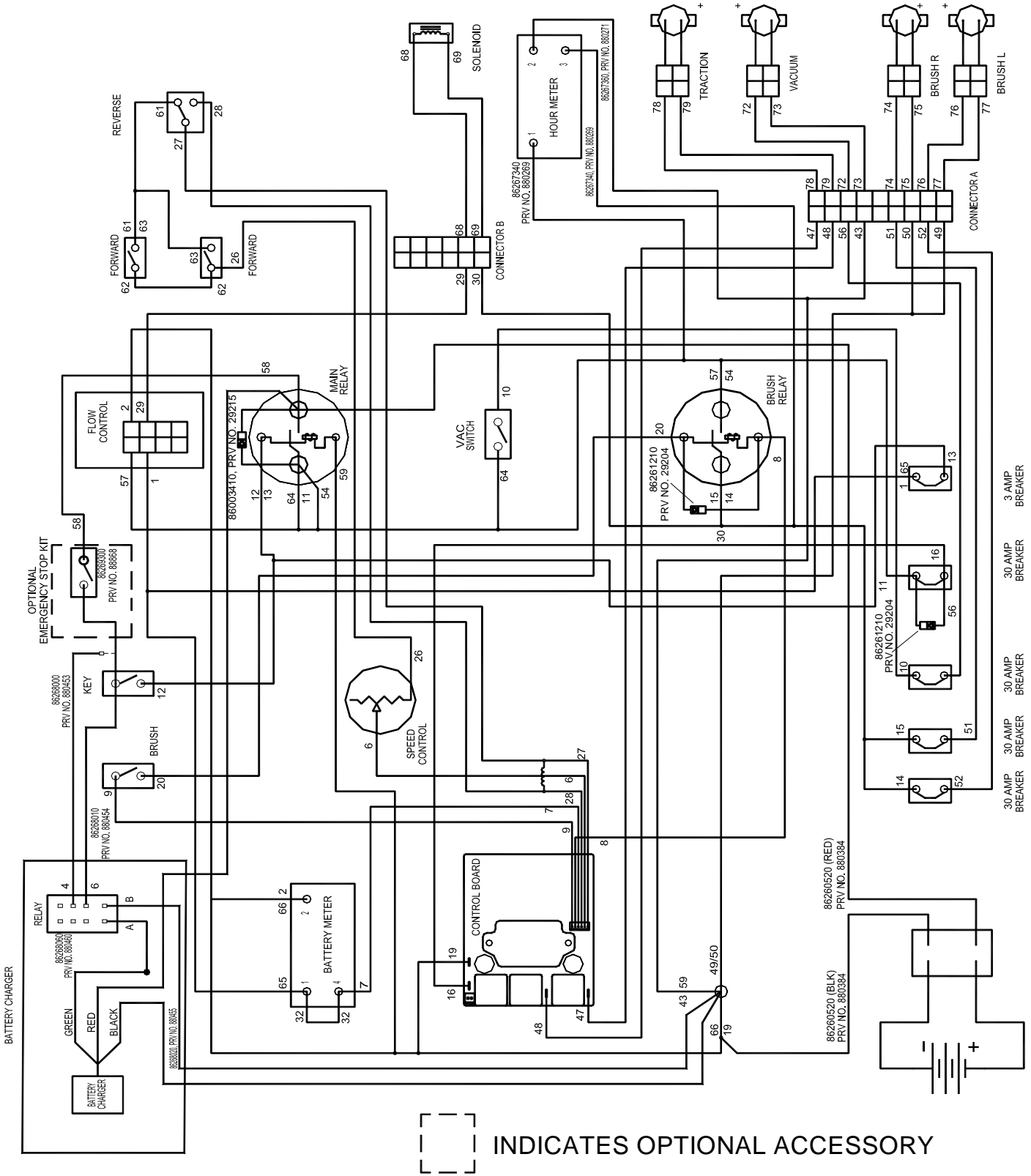

# BRAKE-OPTION

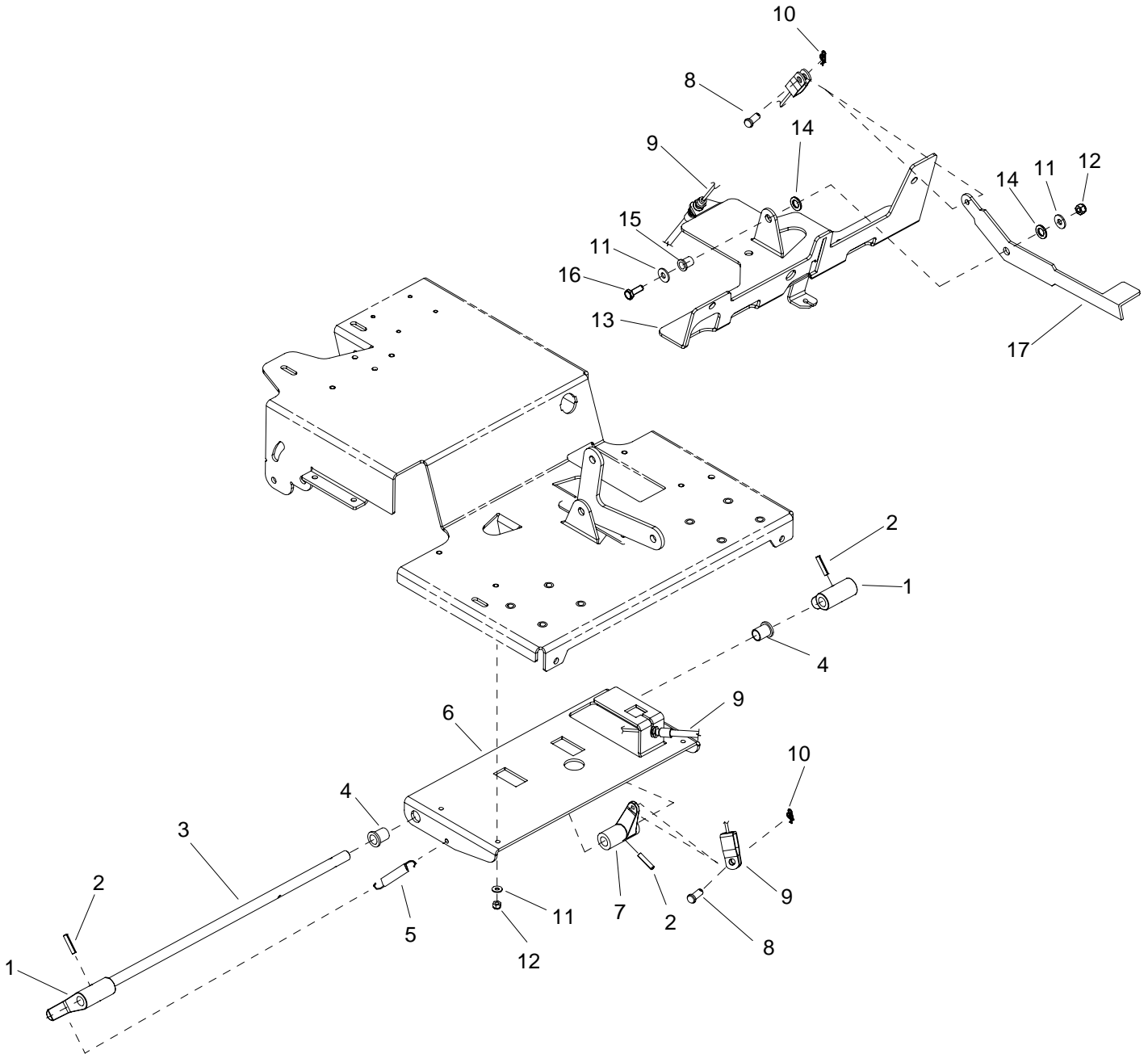

**BRAKE-OPTION**

REF	PART NO.	PRV NO.	QTY	DESCRIPTION	SERIAL NO. FROM	NOTES:
1	86248370	66381	2	PAD, BRAKE		
2	86006220	66192	3	PIN, ROLL 1/4 X 1.25L		
3	86251800	67485	1	ROD, BRAKE 36V		
4	86231330	14664	2	BUSH, BRZ FLG .63 X .75 X 1.0		
5	86255060	73426	2	SPRING, EXT .43D X2.50L X.047W		
6	86070070	140565	1	BRKT, LOWER BRAKE MOUNT 24V		
7	86234850	27956	1	CRANK, BRAKE		
8	86272610	80669	2	PIN, CLEVIS 5/16" X 3/4" L PLTD		
9	86231820	27961	1	CABLE, PARK BRAKE		
10	86008660	80605	2	COTTER, 5/16" RING		
11	86010630	87013	6	WASHER, 1/4 ID X 5/8 OD SS		
12	86271870	57290	5	NUT, 1/4-20 HEX NYLOCK THIN SS		
13	86070150	140574	1	BRKT, TANK MOUNT 24V		
14	86259400	87205	2	WASHER, THRUST .51 ID X 1 OD BRO		
15	86228900	09138	1	BEARING FLANGED .252 ID X .503OD		
16	86273820	70019	1	SCR, 1/2-20 X 1.25 HHCS		
17	86077280	51378	1	LEVER, BRAKE		

# EMERGENCY STOP-OPTION

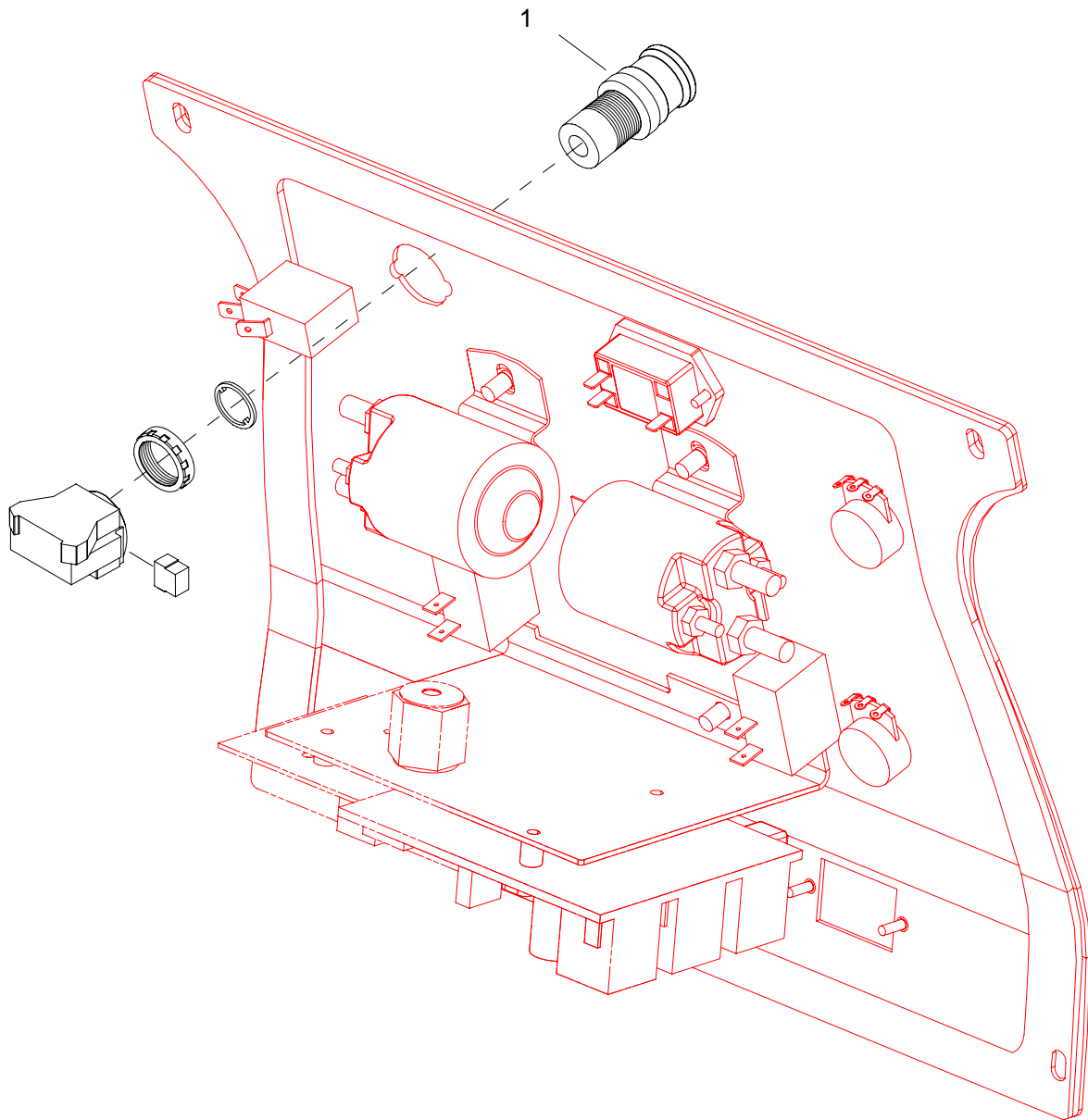

**EMERGENCY STOP-OPTION**

REF	PART NO.	PRV NO.	QTY	DESCRIPTION	SERIAL NO. FROM	NOTES:
1	86007180	72160	1	SWITCH, EMERGENCY STOP		
2	86269300	88868	1	WIRE, 16" RED/18 STRIP X STRIP		NOT SHOWN

# ACCESSORY PUMP-OPTION

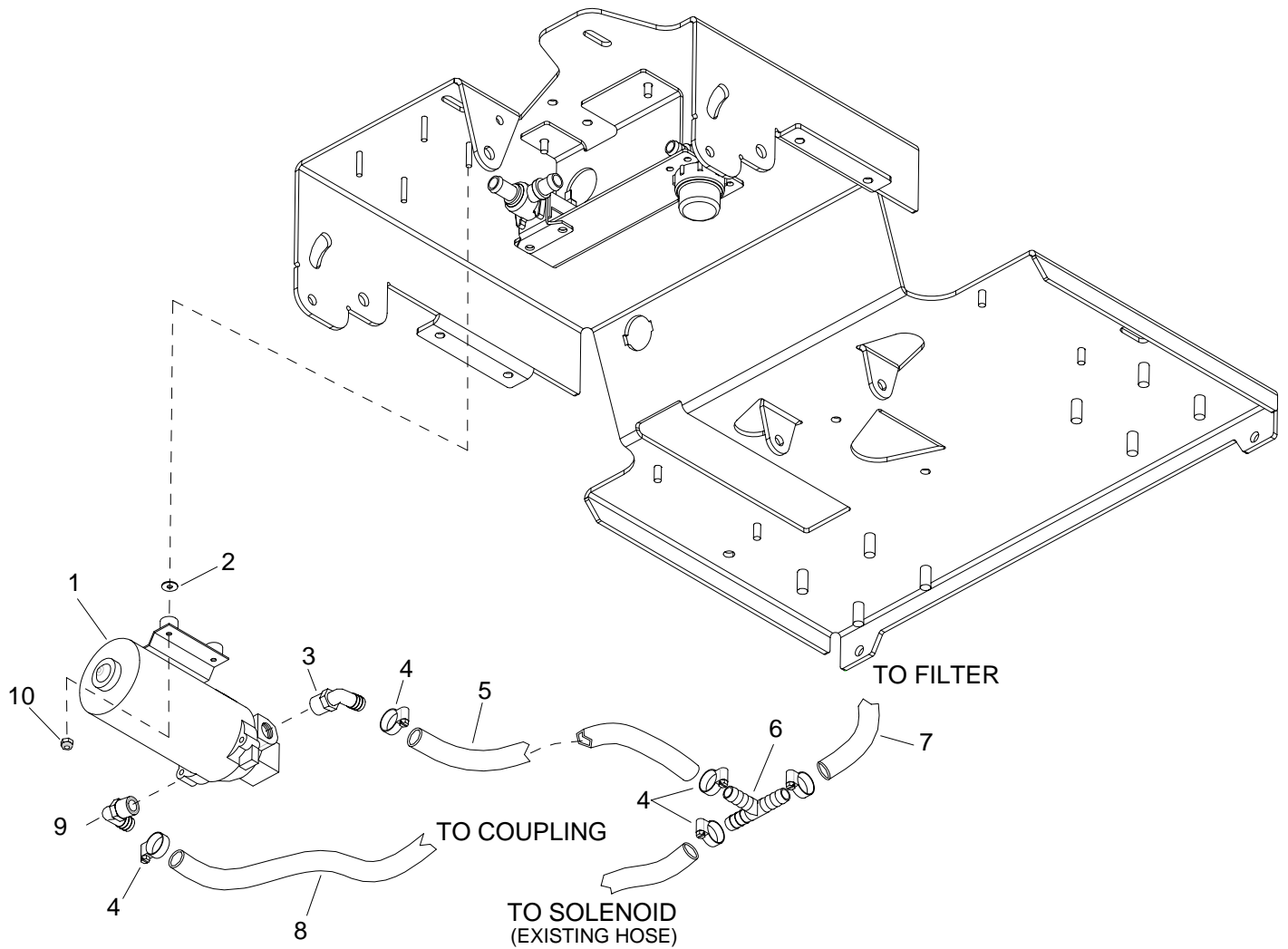
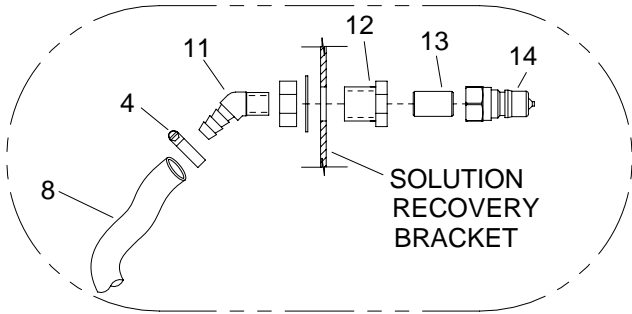

**ACCESSORY PUMP-OPTION**

REF	PART NO.	PRV NO.	QTY	DESCRIPTION	SERIAL NO. FROM	NOTES:
1	86006100	65176	1	PUMP, ASM, 36V ACCESSORY		
2	86010650	87018	4	WASHER, #10 X 9/16 OD		
3	86197940	40027	1	HOSEBARB, 3/8MPT X 1/2 90D DL		
4	86233150	20042	6	CLAMP, 3/8 HOSE (D-SLOT)		
5	86280750	151-38A	1	HOSE, 1/2 WIREBOUND X 21"		
6	86240410	40078	1	HOSEBARB, 1/2 TEE		
7	86282110	39571	1	HOSE, 1/2" WIRE BOUND X 5.5		
8	86282200	39617	1	HOSE, 3/8 X 40" WIRE BOUND		
9	86001550	40043	1	HOSEBARB, 3/8MPT X 3/8 90D		
10	86270990	57090	4	NUT, 10-32 HEX NYLOCK SS		
11	86197620	40038	1	HOSEBARB, 1/4MPT X 3/8 45D DL		
12	86002470	22072	1	COUPLING, 1/4 ANCHOR W/1" HEX		
13	86005590	56014	1	NIPPLE, 1/4 CLOSE		
14	86239020	56012	1	NIPPLE FPT QD		
-	86239020	41463	1	HARNESS PUMP KIT ADAPTER		NOT SHOWN
-	86234940	27051	1	CABLE TIE, 11.38" UL/CSA		NOT SHOWN

# BATTERY CHARGER-SCC326

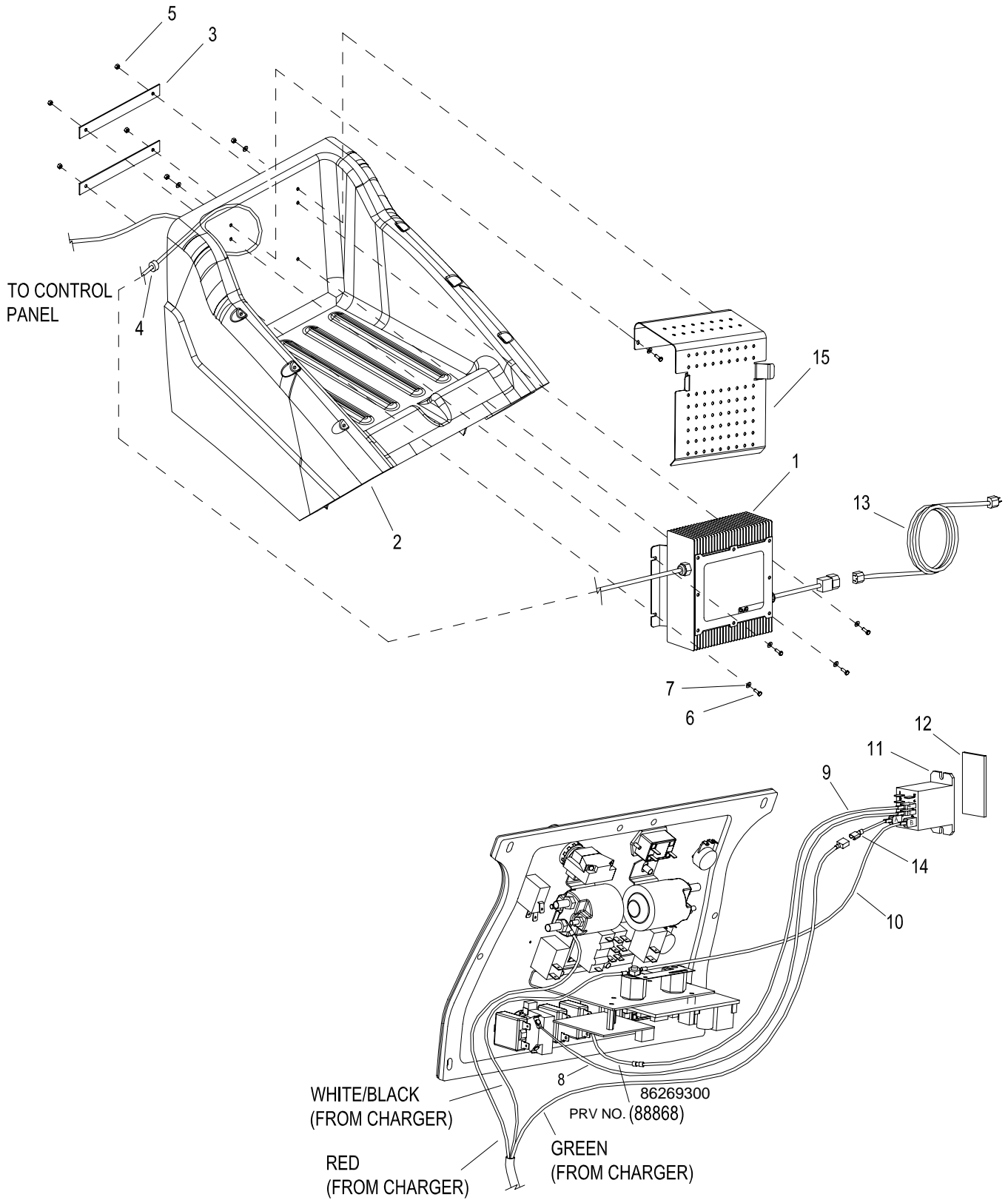

**BATTERY CHARGER-SCC326**

REF	PART NO.	PRV NO.	QTY	DESCRIPTION	SERIAL NO. FROM	NOTES:
1	86023295	270127	1	CHARGER, DELTA-Q, 36V, 21A		
2	86031800	279002	1	COVER, TOP, 36V GRY OBC		
3	86073430	149986	2	BRKT, CHARGER DELTA-Q		
4	86226550	36055	1	GROMMET, 1/2 ID X 1/4 GROOVE		
5	86005810	57245	6	NUT, 1/4-20 HEX NYLOCK SS		
6	86275490	70489	6	SCR, 1/4-20 X 1.0 BH BLK PLATE		
7	86279520	87172	8	WASHER, 1/4 ID FLAT BLK		
8	86268010	880454	1	WIRE, 20" RED/16 76033 X STRIP		
9	86268000	880453	1	WIRE, 12" RED/16 76033 X 76009		
10	86268020	880455	1	WIRE, 20" BLK/16 76001 X 76033		
11	86251410	67506	1	RELAY, 15A 36V MINI		
12	86133400	99817	0.125	TAPE, 1/32T X 1.0 2SA		
13	86234390	23725	1	CORD ASM, 16/3 SJTW X 2M IEC		
14	86268060	880460	1	WIRE, 2" GRN/16 76033 X 76044		
15	86075390	270147	1	COVER, CHARGER DELTA-Q		

## **SUGGESTED SPARE PARTS**

PART NO.	PRV NO.	DESCRIPTION	SERIAL NO. FROM	NOTES:
86001910	14606	BREAKER, 30A 50VDC		
86002000	14717	BREAKER, 3A		
86006370	67315	RELAY, 36VDC 100A HVY DUTY		
86007140	72130	SWITCH, SPST 2-POSITION ROCKER		
86009200	81535	KNOB, 3/8-16 4 PRONG		
86007490	730133	SQUEEGEE, REAR BLADE, LINATEX		
86009830	82528	SQUEEGEE, FRONT BLADE LINATEX		
86003990	35250	GASKET, DOME		
86236410	34394	FLOAT, VAC SHUT OFF		
86001430	140528	BLADE, AQ LEFT 16 INCH		
86001420	140527	BLADE, AQ RIGHT 16 INCH		
86004860	48073	KEY, SWITCH		
86007530	730145	SKIRT, 32 INCH LEFT		
86007540	730146	SKIRT, 32 INCH RIGHT		
86230700	140550	BRUSH SET, VAC MOTOR AMETEK		
86135310	140686	BRUSH SET, VAC 24V/36V WINDSOR		

**NOTES:**



Manufacturers of Innovative Building Maintenance Equipment

Windsor Industries, Inc.  
1351 West Stanford Avenue  
Englewood, CO 80110 USA

Phone: 303.762.1800  
FAX: 303.762.0817  
<http://www.windsorind.com>

### EC Declaration of Conformity

We herewith declare, Windsor Industries, Inc.  
1351 W. Stanford Ave.  
Englewood, CO 80110-5545 USA

that the following product complies with the appropriate essential health and safety requirements of the relevant EC Directives listed below, based on the relevant sections of the applicable EC standards and other normative documents.

**Product:** Saber Cutter 326  
Saber Cutter Deluxe 326

**Product Identification:** Rated 36 VDC 70 A

**Trademark:**



**Model/Type Ref.:** SC326  
SCX326

**Product Description:** This product is a battery powered, self-propelled, wet floor scrubber intended for commercial use.

**Applicable EC Directives:** EC Machinery Directive  
(89/392/EEC & 91/368/EEC & 93/44/EEC & 93/68/EEC)  
EC Low Voltage Directive  
(73/23/EEC & 93/68/EEC)  
EC Directive of Electromagnetic Compatibility  
(89/336/EEC & 93/68/EEC)

**Applicable Harmonized Standards:** EN 60335-1: 1991  
EN 60335-2-67: 1992  
EN 60335-2-72: 1995  
EN 55022: 1998-09  
EN 55011: 1998-05  
EN 61000-6-2: 1999  
EN 61000-4-2: 1995  
EN 61000-4-3: 1997

  
Authorized Signature

4/10/02  
Date

**Title of Signature:** Vice President, Windsor Industries, Inc.



Manufacturers of Innovative Building Maintenance Equipment

Windsor Industries, Inc.  
1351 West Stanford Avenue  
Englewood, CO 80110 USA

Phone: 303.762.1800  
FAX: 303.762.0817  
http://www.windsorind.com

### EC Declaration of Conformity

We herewith declare, Windsor Industries, Inc.  
1351 W. Stanford Ave.  
Englewood, CO 80110-5545 USA

that the following product complies with the appropriate essential health and safety requirements of the relevant EC Directives listed below, based on the relevant sections of the applicable EC standards and other normative documents.

**Product:** Saber Cutter 326  
Saber Cutter Deluxe 326

**Product Identification:** Rated 36 VDC 70 A

**Trademark:**  

**Model/Type Ref.:** SCE326  
SCEX326

**Product Description:** This product is a battery powered, self-propelled, wet floor scrubber intended for commercial use.

**Applicable EC Directives:** EC Machinery Directive  
(89/392/EEC & 91/368/EEC & 93/44/EEC & 93/68/EEC)  
EC Low Voltage Directive  
(73/23/EEC & 93/68/EEC)  
EC Directive of Electromagnetic Compatibility  
(89/336/EEC & 93/68/EEC)

**Applicable Harmonized Standards:** EN 60335-1: 1991  
EN 60335-2-67: 1992  
EN 60335-2-72: 1995  
EN 55022: 1998-09  
EN 55011: 1998-05  
EN 61000-6-2: 1999  
EN 61000-4-2: 1995  
EN 61000-4-3: 1997

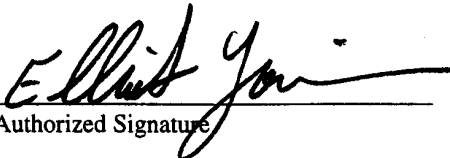
  
Authorized Signature

4-10-02  
Date

**Title of Signature:** Vice President, Windsor Industries, Inc.

